

C532/ES5432**User's Manual**

Table of contents

1	Before starting	4
	Cautions Related to Safety	5
	General Cautions	6
	About This Manual	8
	About Descriptions	8
	Trademarks and Other Information	10
	License	12
2	Setting Up	13
	Installation Requirements	14
	Installation Environment	14
	Installation Space	15
	Checking the Accessories	17
	Unpacking and Installing the Machine	18
	Installing the Optional Equipment	21
	Installing the Wireless LAN module	21
	Installing the Additional Tray Unit	22
	Setting the Printer Driver	24
	Connecting the Power Cord	26
	Connecting a LAN Cable/USB Cable	28
	Connecting a LAN Cable	28
	Connecting a USB Cable	29
	Loading Paper in the Tray	31
	Setting Up This Machine	33
	Language Setup	33
	Setting Date and Time	34
	Setting the Administrator Password	34
	Network Settings	35
	Test Print	36
	Connecting to a Wireless LAN (Only When the Wireless LAN Module is Mounted)	37
	Before Connecting to a Wireless LAN	37
	Enabling Wireless LAN Connection	38
	Connecting to an Access Point (Infrastructure)	39
	Connecting to the Machine Directly	43
	Installing a Driver and Software to a Computer	45
	For Windows	45
	For Mac OS X	48
3	Basic Operations	51
	Names of Components	52
	Front View	52
	Rear View	53
	Inside of the machine	53
	Basic Operations on the Operator Panel	54
	Names and Functions	54
	Entering with the Numeric Keypad	55
	Turning the Machine On or Off	56
	Turning the Machine On	56
	Turning the Machine Off	57
	Loading Paper	58
	About Paper Types That Can be Loaded	58
	Loading Paper in Tray 1/2/3	61
	Loading Paper in the MP Tray	63
	Paper storage	64
4	Print	65
	Printing from a Computer (Windows)	66
	For Windows PCL Printer Driver	66
	For Windows PS Printer Driver	67
	Printing from a Computer (Mac OS X)	69
	Cancelling a Print Job	70
	About Screens and Functions of Each Printer Driver	71
	Windows PCL Printer Driver	71
	Windows PS Printer Driver	73
	Mac OS X PS Printer Driver	75
5	Maintenance	80
	Replacing Consumables	81
	Cautions When Replacing Consumables	81
	Replacing the Toner Cartridges	82
	Replacing the Image Drum	85
	Replacing the Image Drum and Toner Cartridge at the Same Time	88
	Cleaning Each Part of the Machine	91
	Cleaning the LED Head	91
6	Troubleshooting	93
	If Paper Jams Occur	94
	If the Error Code is "370", "371", "372"	94
	If the Error Code is "380", "381", "382", "385", "389"	98

If the Error Code is "390"	101
If the Error Code is "391", "392", "393"	103
If the Error Code is "409"	104
Print Problems	108
Unable to Print	108
If an Error Message is Displayed on the Operator Panel	110
Error Message List	110
7 Operating Management/ Specifications	118
Changing the Administrator Password	119
Saving Power Consumption with the Power Save Function	120
Setting the Length of Idle Time Before Entering Power Save Mode	120
Setting the Length of Idle Time Before Entering Sleep Mode	121
Restrictions in Power Saving Function	121
Automatically Turning the Machine Off (Auto Power Off)	122
Setting the Length of Idle Time Before Auto Power Off Works	123
Specifications	124
General Specifications	124
Printing Specifications	125
Network Specifications	126
Wireless LAN Specifications (Option)	126
Contact Us	128

1

Before starting

[Cautions Related to Safety](#)



[General Cautions](#)

[About This Manual](#)









[Trademarks and Other Information](#)









[License](#)



Cautions Related to Safety



 WARNING	Indicates additional information which, if ignored or not followed, may result in personal injury or death.
 CAUTION	Indicates additional information which, if ignored, may result in personal injury.

General Cautions

 WARNING	
	Do not touch the safety switch inside this machine. High voltage may occur, resulting in electric shock. Also, a gear may rotate, resulting in injury.
	Do not use a highly combustible spray near this machine. Some parts inside the machine become very hot, possibly resulting in fire.
	If the cover becomes extremely hot, the machine emits smoke or odor, or you hear a strange sound, unplug the power plug from the outlet, and contact your dealer. Fire may result.
	If liquid such as water gets inside the machine, unplug the power plug from the outlet, and contact your dealer. Fire may result.
	If you drop a clip or other foreign objects into the machine, unplug the power plug from the outlet, and take the foreign objects out. Electric shock, fire, or injury may result.
	Do not perform any operation or disassembly other than instructed in the user manual. Electric shock, fire, or injury may result.
	If the machine is dropped or the cover is damaged, unplug the power plug from the outlet, and contact your dealer. Electric shock, fire, or injury may result.
	Unplug the power plug regularly, and clean the bases of and in between the plug blades. If the power plug is left plugged into the outlet for an extended period of time, dust adheres on the bases of the plug blades, and a short may occur, possibly resulting in fire.

 WARNING	
	Do not vacuum spilled toner with an electric vacuum cleaner. Vacuuming spilled toner with an electric vacuum cleaner may result in ignition due to sparks from electric contacts or other reasons. If toner spills on the floor or other places, wipe the toner gently with a damp rag or other cloth while using care not to scatter the toner.
	Do not insert any object into a vent hole. Electric shock, fire, or injury may result.
	Do not place a cup filled with water or other objects on the machine. Electric shock or fire may result.
	Do not let pet urine or other liquid get inside this machine, or allow this machine to get wet. Electric shock or fire may result.
	When the machine cover is opened, do not touch the fuser unit. Burns may result.
	Do not throw the toner cartridge or image drum into a fire. The toner may ignite, resulting in burns.
	Do not connect the power cord, cables, or the ground wire in any way other than instructed in the user manual. Fire may result.
	Operation using an UPS (uninterruptible power supply) or inverter is not guaranteed. Do not use an uninterruptible power supply or inverter. Fire may result.

 CAUTION	
	Do not go near the paper output part when you turn the power on or when printing is in progress. Injury may result.

 CAUTION	
	Do not touch a broken liquid crystal display. Injury may result. If you get liquid (liquid crystal) spilled from the liquid crystal display into your eyes or mouth, immediately rinse with a large amount of water. Seek medical advice if necessary.
	Do not disassemble the image drum or toner cartridge, or force them open. You may inhale the scattered toner, or the toner may land on your hands or clothes, making them dirty.

NOTE!

This product is not intended for use in the immediate visual field on the display work place. To avoid disturbing reflections on the display work place, this product shall not be placed in the immediate field of vision.

About This Manual

Various information about this manual is provided here. Read these sections before using this manual.

• Disclaimer

Every effort has been made to ensure that the information in this document is complete, accurate, and up-to-date. The manufacturer assumes no responsibility for the result of errors beyond its control. The manufacturer also cannot guarantee that changes in software and equipment made by other manufacturers and referred to in this manual will not affect the applicability of the information in it. Mention of software products manufactured by other companies does not necessarily constitute endorsement by the manufacturer.

While all reasonable efforts have been made to make this document as accurate and helpful as possible, we make no warranty of any kind, expressed or implied, as to the accuracy or completeness of the information contained herein.

• Copyright of the manual

All rights reserved by Oki Electric Industry Co., Ltd. No part of this document may be reproduced in any form or by any means without prior written permission from Oki Electric Industry Co., Ltd.

© 2017 Oki Electric Industry Co., Ltd.

• Manual Composition

The following manual is included in this product.

- User's Manual (PDF) ----- Stored in the DVD-ROM which comes with the machine.
- Advanced Manual (PDF) ----- Download this manual from the web site and refer to it.

• [About Descriptions](#)

- [How to Use This Manual \(Advanced Manual\)](#)

About Descriptions

Marks, symbols, illustrations, and other descriptions are provided.

- [About Marks](#)
- [About Symbols](#)
- [About Illustrations](#)



Unless otherwise specified, this manual uses screenshots of the following screens.

- For Windows: Windows 7
- For Mac OS X: Mac OS X 10.9

[OKI Printer] may be written as the model name.

Depending on your OS, model or version, the description on this document may be different.

About Marks

This manual uses the following marks.

Symbol	Meaning
	Indicates the cautions and restrictions for operating this machine correctly. Be sure to read to ensure that you can operate the machine correctly.
	Indicates information that is useful for using this machine. It is recommended to read.
	Indicates a reference topic. Read when you need more information.
	Indicates a related topic. Read when you need related information.

About Symbols

This section describes symbols and their meaning in this manual.

Symbol	Meaning
Illustration (button name)	Indicates a button (button name) on the operator panel of the machine.

Symbol	Meaning
[]	Indicates a menu name, item name, option, or other items that are displayed on the display screen of the operator panel. Indicates a menu, window, or dialog box name that is displayed on the screen on a computer. They can be clearly distinguished in descriptions or illustrations in procedures.
" "	Indicates a message on the displayed on the display screen or entered text. Indicates a file name on a computer. Indicates the topic title of a link destination.
< >	Indicates a key on the computer keyboard.
>	Indicates how to display the required menu of the machine or computer.

About Illustrations

The illustrations of C532 are used in this manual as examples.

Illustrations of the display screen used in this manual are with the factory default settings.



The descriptions in this manual may vary depending on your model.

Trademarks and Other Information

OKI is a registered trademark of Oki Electric Industry Co., Ltd.

ENERGY STAR is a trademark of the United States Environmental Protection Agency.

Microsoft, Windows, Windows Server, Windows Vista and Internet Explorer are registered trademarks of Microsoft Corporation.

Apple, Macintosh, Mac and Mac OS are the registered trademarks of Apple Inc.

iPad, iPhone, iPod, iPod touch and Safari are trademarks registered to Apple Inc. in the United States and other countries.



AirPrint and the AirPrint logo are trademarks of Apple Inc.

Google, Google Docs, Android, and Gmail are trademarks of Google Inc.

Google Cloud Print is a trademark of Google Inc.

Adobe, Illustrator, Photoshop, PostScript and Reader are trademarks or trademarks of Adobe Systems Incorporated in the United States and other countries.

FeliCa is a registered trademark of Sony Corporation.

MIFARE is a trademark of NXP Semiconductors.

Other product names and brand names are registered trademarks or trademarks of their proprietors.

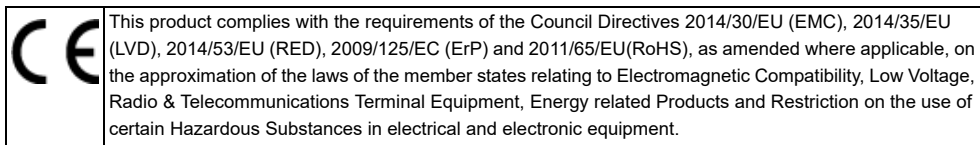

The following cables were used to evaluate this product for EMC directive 2014/30/EU compliance, and configurations other than this may affect that compliance.

CABLE TYPE	LENGTH (METER)	CORE	SHIELD
Power	1.8	X	X
USB	5.0	X	✓
LAN	10.0	X	X
Telephone	3.0	X	X

• ENERGY STAR

Target countries of the ENERGY STAR program are the United States, Canada and Japan.

It is not applicable to other countries.

This product is compliant with ENERGY STAR v2.0 only.

• EMERGENCY FIRST AID

Take care with toner powder:



If swallowed, give small amounts of cold water and seek medical attention. DO NOT attempt to induce vomiting.

If inhaled, move the person to an open area for fresh air. Seek medical attention. If it gets into the eyes, flush with large amounts of water for at least 15 minutes keeping eyelids open. Seek medical attention.

Spillages should be treated with cold water and soap to help reduce risk of staining skin or clothing.

• ENVIRONMENTAL INFORMATION



License

This product contains software developed by the Heimdal Project.

Copyright (c) 1995 - 2008 Kungliga Tekniska Högskolan

(Royal Institute of Technology, Stockholm, Sweden).

All rights reserved.

Redistribution and use in source and binary forms, with or without modification, are permitted provided that the following conditions are met:

- 1 Redistributions of source code must retain the above copyright notice, this list of conditions and the following disclaimer.
- 2 Redistributions in binary form must reproduce the above copyright notice, this list of conditions and the following disclaimer in the documentation and/or other materials provided with the distribution.
- 3 Neither the name of the Institute nor the names of its contributors may be used to endorse or promote products derived from this software without specific prior written permission.

THIS SOFTWARE IS PROVIDED BY THE INSTITUTE AND CONTRIBUTORS "AS IS" AND ANY EXPRESS OR IMPLIED WARRANTIES, INCLUDING, BUT NOT LIMITED TO, THE IMPLIED WARRANTIES OF MERCHANTABILITY AND FITNESS FOR A PARTICULAR PURPOSE ARE DISCLAIMED. IN NO EVENT SHALL THE INSTITUTE OR CONTRIBUTORS BE LIABLE FOR ANY DIRECT, INDIRECT, INCIDENTAL, SPECIAL, EXEMPLARY, OR CONSEQUENTIAL DAMAGES (INCLUDING, BUT NOT LIMITED TO, PROCUREMENT OF SUBSTITUTE GOODS OR SERVICES; LOSS OF USE, DATA, OR PROFITS; OR BUSINESS INTERRUPTION) HOWEVER CAUSED AND ON ANY THEORY OF LIABILITY, WHETHER IN CONTRACT, STRICT LIABILITY, OR TORT (INCLUDING NEGLIGENCE OR OTHERWISE) ARISING IN ANY WAY OUT OF THE USE OF THIS SOFTWARE, EVEN IF ADVISED OF THE POSSIBILITY OF SUCH DAMAGE.

- **Open Source License Disclosure**

The following open source software is included to use Google Cloud Print. The descriptions about the open source license are as follows.

json-c

Copyright (c) 2009-2012 Eric Haszlakiewicz

Permission is hereby granted, free of charge, to any person obtaining a copy of this software and associated documentation files (the "Software"), to deal in the Software without restriction, including without limitation the rights to use, copy, modify, merge, publish, distribute, sublicense, and/or sell copies of the Software, and to permit persons to whom the Software is furnished to do so, subject to the following conditions:

The above copyright notice and this permission notice shall be included in all copies or substantial portions of the Software.

THE SOFTWARE IS PROVIDED "AS IS", WITHOUT WARRANTY OF ANY KIND, EXPRESS OR IMPLIED, INCLUDING BUT NOT LIMITED TO THE WARRANTIES OF MERCHANTABILITY, FITNESS FOR A PARTICULAR PURPOSE AND NON INFRINGEMENT. IN NO EVENT SHALL THE AUTHORS OR COPYRIGHT HOLDERS BE LIABLE FOR ANY CLAIM, DAMAGES OR OTHER LIABILITY, WHETHER IN AN ACTION OF CONTRACT, TORT OR OTHERWISE, ARISING FROM, OUT OF OR IN CONNECTION WITH THE SOFTWARE OR THE USE OR OTHER DEALINGS IN THE SOFTWARE.

Copyright (c) 2004, 2005 Metaparadigm Pte Ltd

Permission is hereby granted, free of charge, to any person obtaining a copy of this software and associated documentation files (the "Software"), to deal in the Software without restriction, including without limitation the rights to use, copy, modify, merge, publish, distribute, sublicense, and/or sell copies of the Software, and to permit persons to whom the Software is furnished to do so, subject to the following conditions:

The above copyright notice and this permission notice shall be included in all copies or substantial portions of the Software.

THE SOFTWARE IS PROVIDED "AS IS", WITHOUT WARRANTY OF ANY KIND, EXPRESS OR IMPLIED, INCLUDING BUT NOT LIMITED TO THE WARRANTIES OF MERCHANTABILITY, FITNESS FOR A PARTICULAR PURPOSE AND NON INFRINGEMENT. IN NO EVENT SHALL THE AUTHORS OR COPYRIGHT HOLDERS BE LIABLE FOR ANY CLAIM, DAMAGES OR OTHER LIABILITY, WHETHER IN AN ACTION OF CONTRACT, TORT OR OTHERWISE, ARISING FROM, OUT OF OR IN CONNECTION WITH THE SOFTWARE OR THE USE OR OTHER DEALINGS IN THE SOFTWARE.

2

Setting Up

Installation Requirements

Checking the Accessories

Unpacking and Installing the Machine

Installing the Optional Equipment

Connecting the Power Cord

Connecting a LAN Cable/USB Cable

Loading Paper in the Tray

Setting Up This Machine

Connecting to a Wireless LAN (Only When the Wireless LAN Module is Mounted)

Installing a Driver and Software to a Computer

Installation Requirements

- [Installation Environment](#)
 - [Installation Space](#)
-

Installation Environment

Install the machine in the following environment.

Ambient temperature: 10°C to 32°C

Ambient humidity: 20% to 80% RH (relative humidity)

Maximum wet bulb temperature: 25°C



- Use care to prevent condensation. It may cause a malfunction.
- If installing your machine where the ambient humidity is 30% RH or below, use a humidifier or antistatic mat.
- Depending on the installation environment, the operation noise may be louder. If the noise bothers you, we suggest you to install the machine in the place away from you or in another room.

WARNING

- Do not install the machine in a location subject to high temperatures or in a location near fire.
- Do not install the machine in a location where chemical reactions may occur (such as a laboratory).
- Do not install the machine near alcohol, thinners, or other flammable solvents.
- Do not install the machine in a location within the reach of small children.
- Do not install the machine in an unstable location (such as on an unsteady stand or slanted location).
- Do not install the machine in a location with high level of humidity or dust, or in a location where the machine is exposed to direct sunlight.
- Do not install the machine in an environment where it is exposed to salty air or corrosive gas.
- Do not install the machine in a location where it is exposed to a high level of vibration.
- Do not install the machine in a location where its vent hole is blocked.

CAUTION

- Do not install this machine directly on a thick rug or carpet.
- Do not install this machine in a closed room or other locations with bad circulation and ventilation.
- If you use this machine in a small room continuously for an extended period of time, make sure to ventilate the room.
- Install this machine away from a source that emits strong magnetic fields or noise.
- Install this machine away from a monitor or television.
- Moving the machine requires that two people stand in front and back of the machine respectively, hold the handles at the bottom of the machine, and move it.

Installation Space

Install the machine on a flat surface that is wide enough to accommodate the legs of the machine.

Allow for enough room around the machine as shown in the following figures.

• Top view

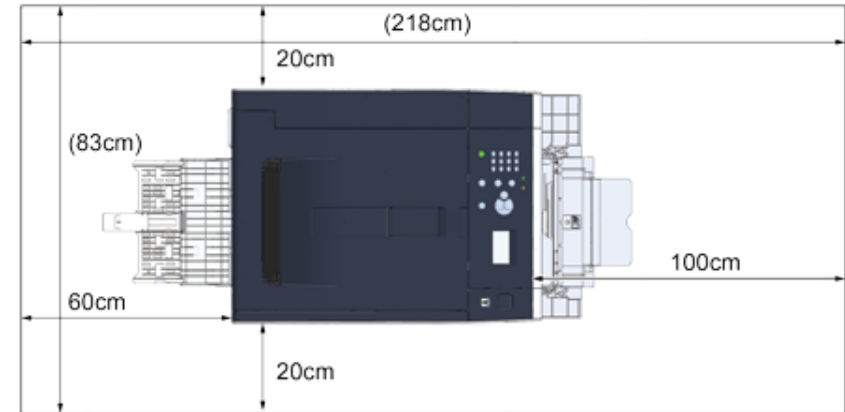

• Side view

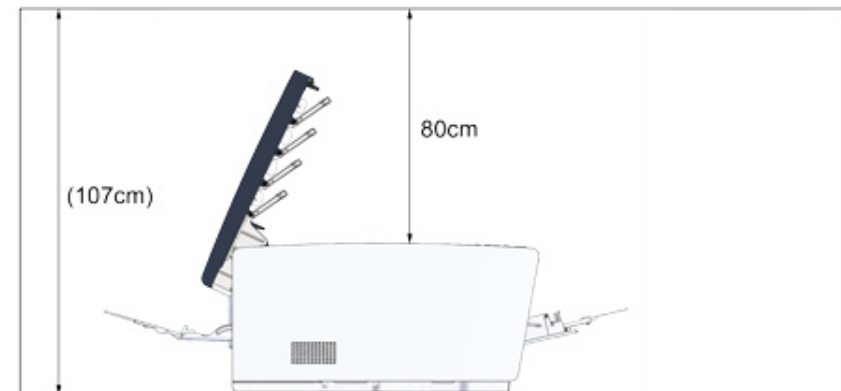

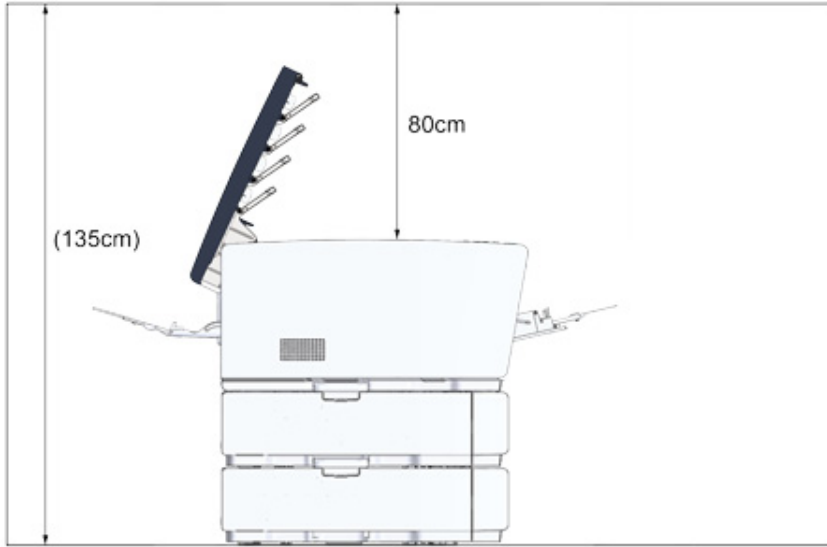

- Side view (when the additional tray unit is installed)



Checking the Accessories

Check that you have everything shown below.

 CAUTION	Injury may result.	
Lift this machine by 2 persons, because it weighs approximately 23 kg.		



Be sure to use the supplied consumables first. If other consumables are used first, the life time may not be shown correctly or supplied consumables may not be applied.

- **Main body**



- **Four image drums (black, cyan, magenta and yellow)**

- **Four starter toner cartridges (black, cyan, magenta and yellow)**

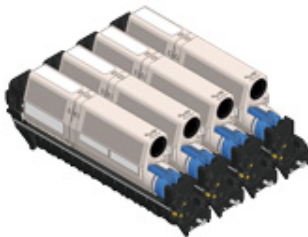

For the C model, the starter toner cartridges are installed in the image drums, which are installed in the machine before shipment.



The starter toner cartridge is not installed in the ES model. Install the toner cartridge that is included in this machine. Refer to "[Replacing the Image Drum](#)".

- **Software DVD-ROM**



- **Power cord**

- **Envelope lever**

The envelope lever is attached to the MP tray. Use the envelope lever if envelopes wrinkle after being printed.



For instructions, refer to "Printing on Envelopes (Advanced Manual)".



- LAN cables or USB cables are not included in the package. Prepare the cable that suits your connection environment separately.
- Packaging and cushioning materials are used when transporting the machine. Do not dispose packaging materials as they may be used in the future.

Unpacking and Installing the Machine

This section describes how to unpack and install the machine.

 CAUTION	Injury may result.	
Lift this machine by 2 persons, because it weighs approximately 23 kg.		



- Use extra care when handling the image drum (the green cylinder), because it is fragile.
- Do not expose the image drum to direct sunlight or strong light (approximately 1,500 lux or more). Even under room lighting, do not leave the image drum for 5 minutes or more.
- Packaging and cushioning materials are required for transporting the machine. Do not dispose of it, and keep it for future use.

- 1 Remove the machine from the box, and then remove accessories, cushioning materials and the plastic bag from the machine.

- 2 Lift the machine, and then place it where it is to be installed.

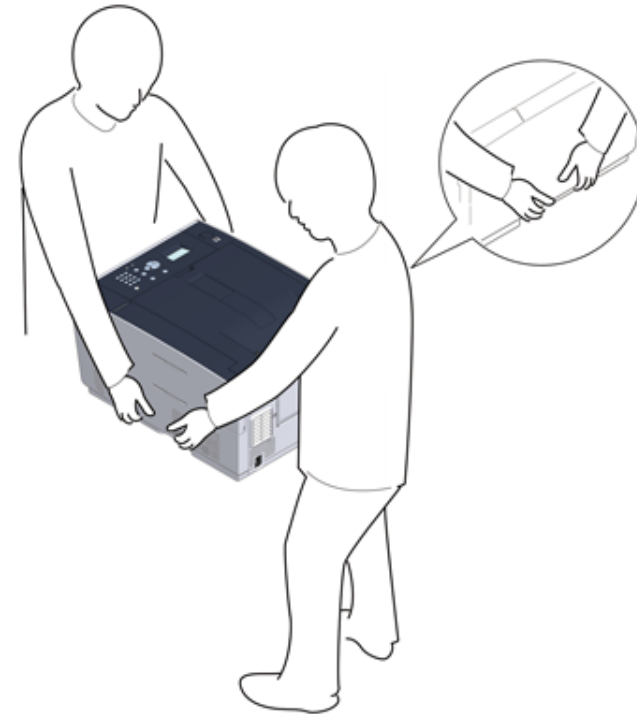

- 3 Remove the protection tapes, protective sheet, and desiccant packs.
- 4 Press the button (A) and open the output tray (a) until it stops.

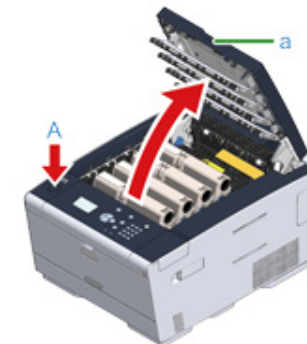

- 5** Pinch the tip of blue lever of the toner cartridge and turn forward until the tip aligns on the lug of the cartridge.
Turn the levers of all 4 toner cartridges.

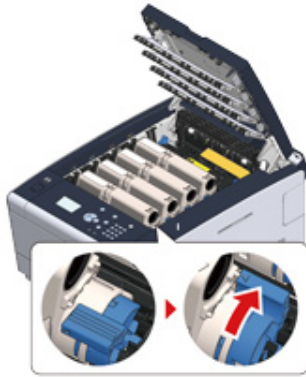

If you close the output tray without turning the blue lever, it may cause a malfunction. Be sure to turn the blue lever until its top aligns on the lug in the back of the toner cartridge.

- 6** Pull the locking levers on the fuser unit toward you to unlock.

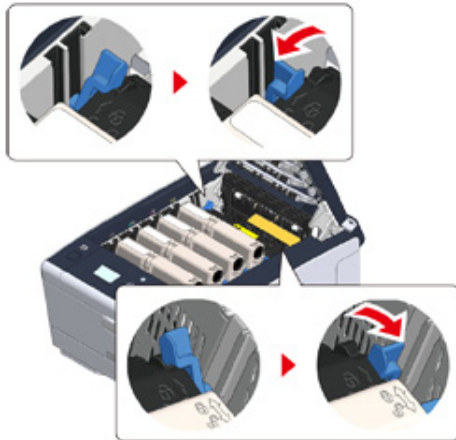

- 7** Hold the fuser unit handle and lift the fuser unit out of the machine.

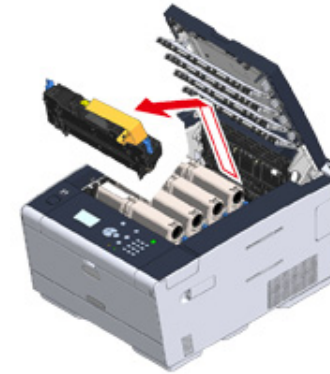

- 8** Push the blue lever on the fuser unit and remove the orange safety stopper and film.

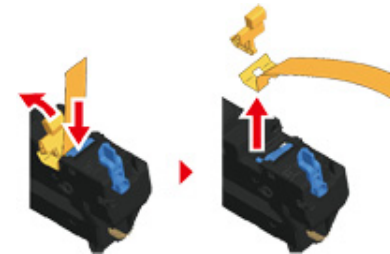

- 9 Hold the fuser unit handle and aligning the fuser unit to the grooves behind the toner cartridges, place the fuser unit into the machine.

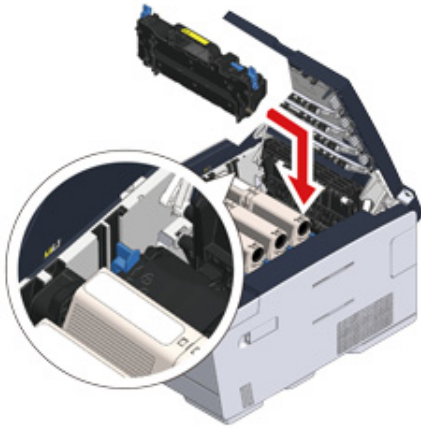

- 10 Push the levers on the fuser unit to lock.

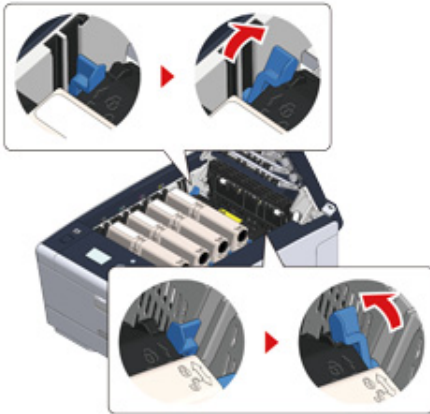

- 11 Close the output tray (a) slowly and push the center of the output tray for confirmation.

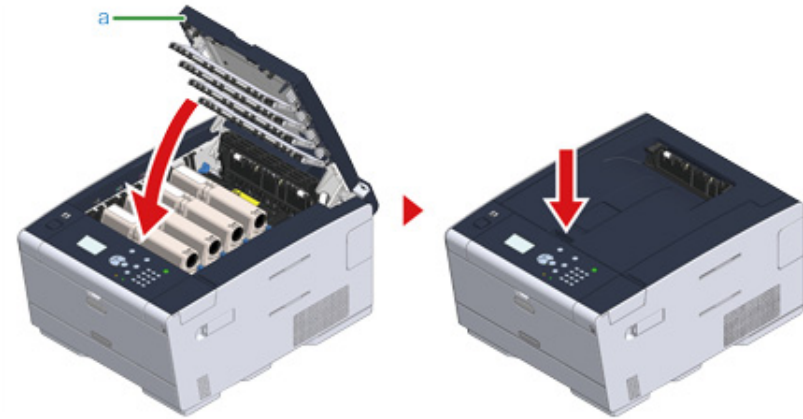

When the error message that the output tray is open does not disappear, make sure that the output tray is closed securely.

Installing the Optional Equipment

This section describes how to install optional equipment.

- [Installing the Wireless LAN module](#)
 - [Installing the Additional Tray Unit](#)
 - [Setting the Printer Driver](#)
-

Installing the Wireless LAN module

Install the wireless LAN module when you want to use a wireless connection. After installing, be sure to change the wireless LAN setting from [DISABLE] to [ENABLE] on the operator panel.

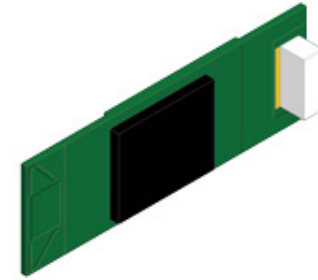

- 1 Check that the machine is turned off and power cord and all the cables are unplugged.



Installing the wireless LAN module with the machine turned on may cause the machine and wireless LAN module to malfunction.

- 2 Open the wireless LAN module cover.



- 3 Eject the connector from the cover and connect with the wireless LAN module.

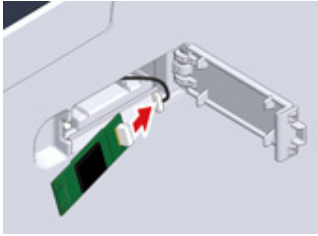

- 4 Install the wireless LAN module to the machine.

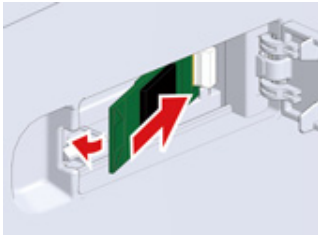

- 5 Close the wireless LAN module cover.

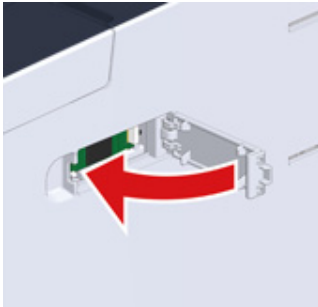

Go to "[Connecting the Power Code](#)".



Attaching the wireless module cannot connect the machine to the wireless LAN.

Enable the wireless setting in the steps in "[Connecting to a Wireless LAN \(Only When the Wireless LAN Module is Mounted\)](#)".

Installing the Additional Tray Unit

Attach the additional tray unit when increasing the number of sheets or paper to be set is needed.

Up to 2 trays can be installed.

Set the number of trays on the printer driver after installing them.

Model Number N36501

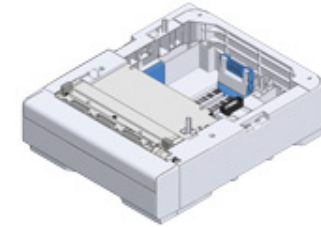

CAUTION

Injury may result.



Lift this machine by 2 persons, because it weighs approximately 23 kg.

- 1 Check that the machine is turned off and power cord and all the cables are unplugged.



Installing the additional tray unit with the machine turned on may cause the machine and additional tray unit to malfunction.

2 If you want to install two additional trays, fix them together with the lock pieces.

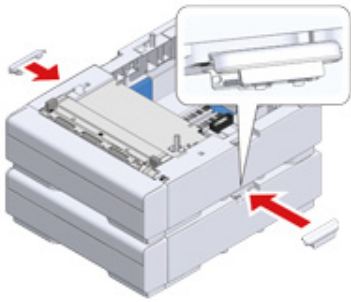

3 Slowly stack the machine on the additional tray unit aligning their back sides and right sides.

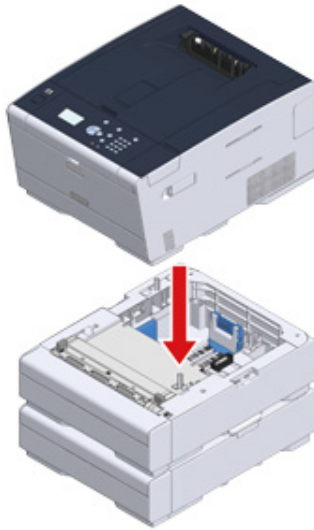

4 Screw the machine and additional tray unit with the lock pieces.



Setting the Printer Driver

When the additional tray unit is installed, be sure to set the number of trays after the printer driver is installed.

For the information of installing the printer driver, see "[Installing the Wireless LAN module](#)".



- To follow this procedure, you must log in to a computer as the administrator.
- If your Mac OS applies to the following conditions, the information about the installed option is automatically obtained, not requiring you to set the printer driver.
 - When the machine is connected to a network over Bonjour
 - When the machine is connected via USB interface
 - When the optional equipment is installed before the printer driver is installed

• Setting Additional Tray(s) to the Windows PCL Printer Driver

- 1 Click [Start], and then select [Devices and Printers].
- 2 Right-click [OKI C532], and then select [OKI C532 PCL6] from [Printer properties].
- 3 Select the [Device Options] tab.

- 4 Enter the total number of trays and then click [OK].

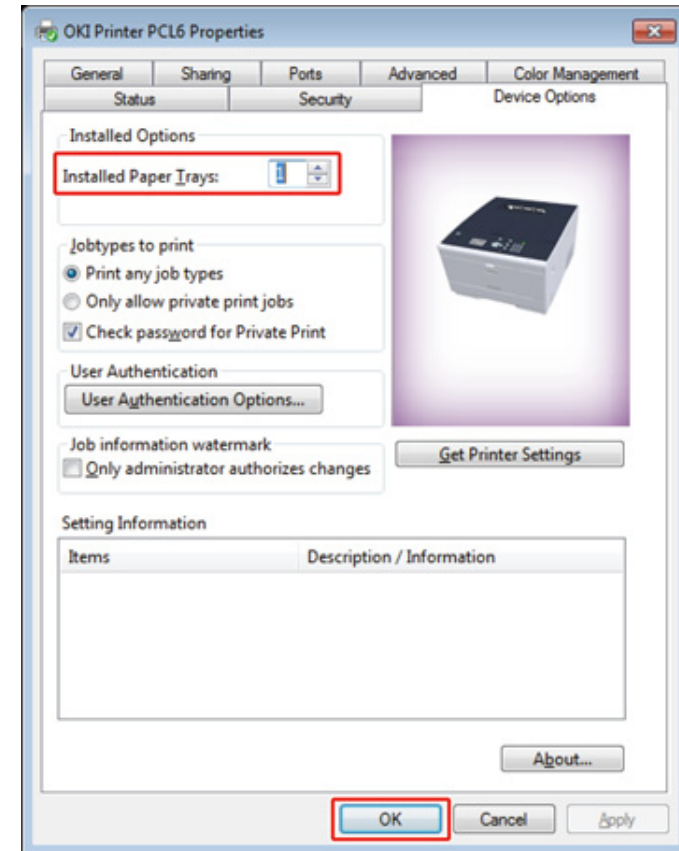

- If a TCP/IP network connection is used, click [Get Printer Settings] to set the number of trays automatically.
- For the Windows XPS printer driver, follow the steps for the Windows PCL printer driver to make a setting.

• Setting Additional Tray(s) to the Windows PS Printer Driver

- 1 Click [Start], and then select [Devices and Printers].
- 2 Right-click [OKI C532], and then select [OKI C532 PS] from [Printer properties].
- 3 Select the [Device Settings] tab.

- 4 Select [Get installed options automatically] for [Installable Options], and then click [Setup].

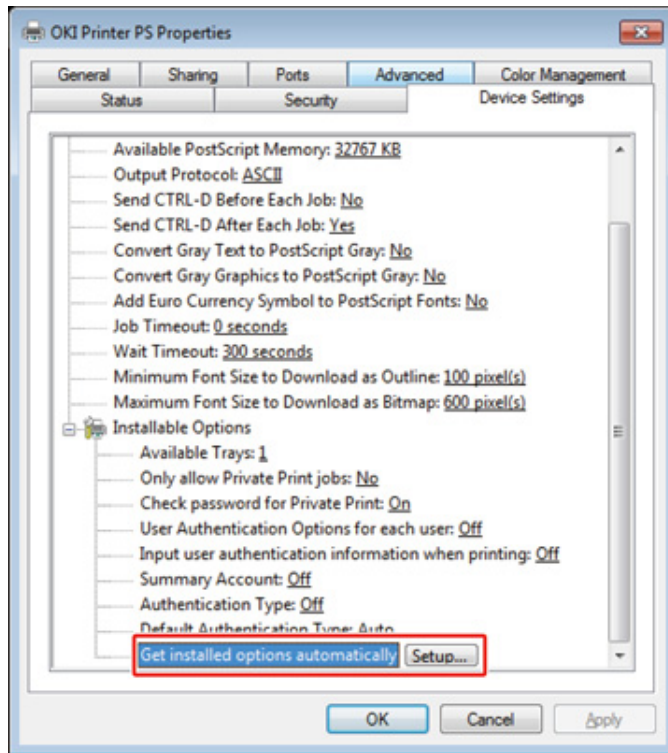

When using a USB connection, select the total number of trays for [Available Trays] in [Installable Options].

- 5 Click [OK].

• Setting Additional Tray(s) to the Mac OS X Printer Driver

- 1 Select [System Preferences] from the Apple menu.
- 2 Click [Printers & Scanners].
- 3 Select the machine, and then click [Options & Supplies].
- 4 Select the [Options] tab.

- 5 Select the total number of trays for [Available Tray], and then click [OK].

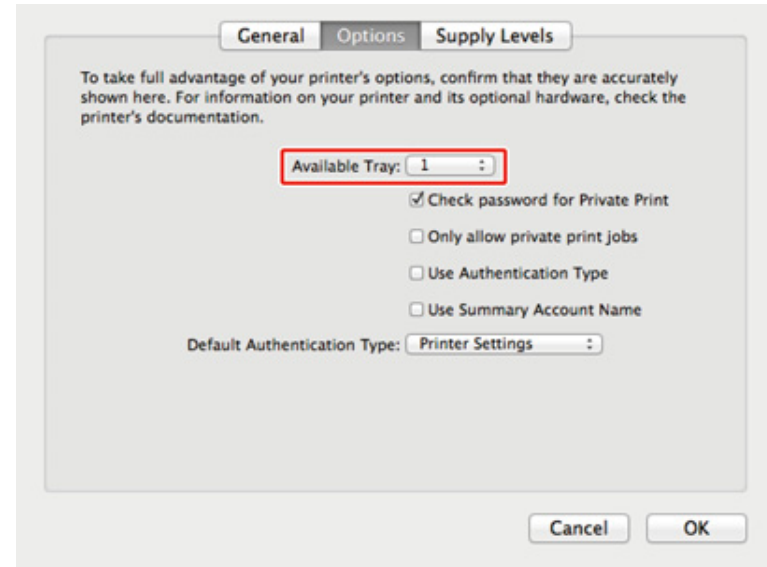

Connecting the Power Code

The power supply must meet the following conditions.

AC: 110 to 127V AC (Range 99 to 140V AC) / 220 to 240V AC (Range 198 to 264V AC)

Frequency: 50/60 Hz \pm 2%



- If the power supply is unstable, use a voltage regulator.
- The maximum power consumption of the machine is 1220 W (120V AC) / 1250 W (230V AC). Check that the power supply is sufficient.
- The operation that uses an uninterruptible power supply (UPS) or inverter is not guaranteed. Do not use an uninterruptible power supply (UPS) or inverter.



WARNING

Fire or electric shock may result.



- Be sure to turn this machine off before connecting and disconnecting the power cord and the ground wire.
- Be sure to connect the ground wire to the designated ground terminal. If this machine cannot be grounded, contact your dealer.
- Be sure not to connect the ground wire to the ground of a water pipe, gas pipe or telephone line, or to a lightning rod.
- Be sure to connect the ground wire before connecting the power cord to the outlet. Also, be sure to unplug the power cord from the outlet before disconnecting the ground wire.
- Be sure to plug or unplug the power cord by holding its power plug.
- Securely plug the power cord into the outlet.
- Do not plug or unplug the power cord with wet hands.
- Install the power cord in a location where users cannot step on it, and do not place any object on the power cord.
- Do not bundle or tie the power cord.
- Do not use a damaged power cord.
- Do not overload the outlet.
- Do not connect the power cords of this machine and other electric products to the same outlet. If the power cord of this machine is connected to the same outlet as other electric products, especially an air conditioning machine, copier, or shredder, this machine may malfunction due to electrical noise. If you have to connect the power cord of this machine to the same outlet as other products, use a commercially available noise filter or noise cut transformer.
- Use the power cord included in this machine, and plug the cord directly into the outlet. Do not use the power cords of other products for this machine.
- Do not use an extension cord. If you have to use an extension cord, use a cord rated 15A or higher.
- Use of an extension cord may result in this machine malfunctioning due to AC voltage drop.
- Do not turn this machine off or unplug the power cord during printing.
- If you do not use this machine for an extended period of time due to holidays, trips, or other reasons, unplug the power cord.
- Do not use the power cord included in this machine for other products.

1 Plug the power cord into the power connector.



2 Plug the power cord into the outlet.

Connecting a LAN Cable/USB Cable

When using the machine in a wired network connection or connecting to a computer via a USB cable, connect the cable in the following steps.

- [Connecting a LAN Cable](#)
- [Connecting a USB Cable](#)

Connecting a LAN Cable



A LAN cable (category 5e or higher, twist pair, straight) is not supplied.

- 1 Prepare a LAN cable (category 5e or higher, twist pair, straight) and hub.

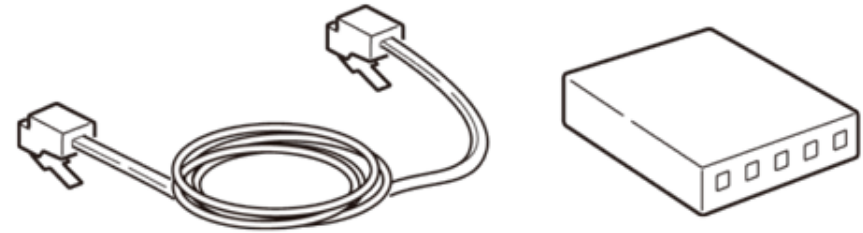

- 2 Check that the machine and computer are turned off.
- 3 Open the interface cover on the back side of the machine pressing the center part of it.



- 4** Insert one end of the LAN cable into the network interface connector.

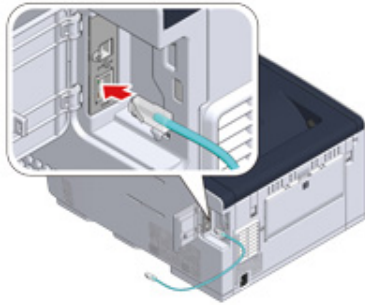

- 5** Pass the LAN cable under the tab, and then close the interface cover.

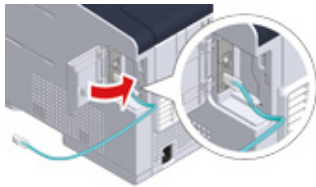

- 6** Insert the other end of the LAN cable into the hub.

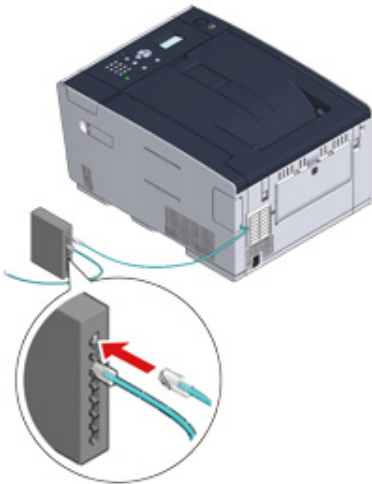

Go to the procedure to "[Loading Paper in the Tray](#)".

Connecting a USB Cable

A USB cable (Hi-Speed USB 2.0) is not supplied.

- 1** Prepare a USB cable.



If you want to connect in USB 2.0 Hi-Speed mode, use a Hi-Speed USB 2.0 USB cable.



- 2** Check that the machine and computer are turned off.
- 3** Open the interface cover on the back side of the machine pressing the center part of it.



- 4** Insert one end of the USB cable into the USB interface connector on the machine.



Do not insert the USB cable into the network interface connector. It may cause a malfunction.

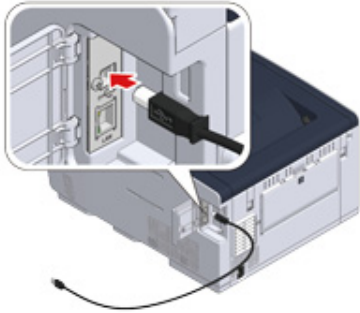

- 5** Pass the USB cable under the tab, and then close the interface cover.

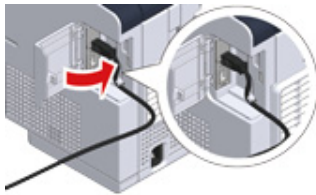

- 6** Insert one end of the USB cable into the USB interface connector on the machine.



For Windows, do not insert the other end of the USB cable into the computer until the instruction is displayed on the screen when the driver installation is in progress.

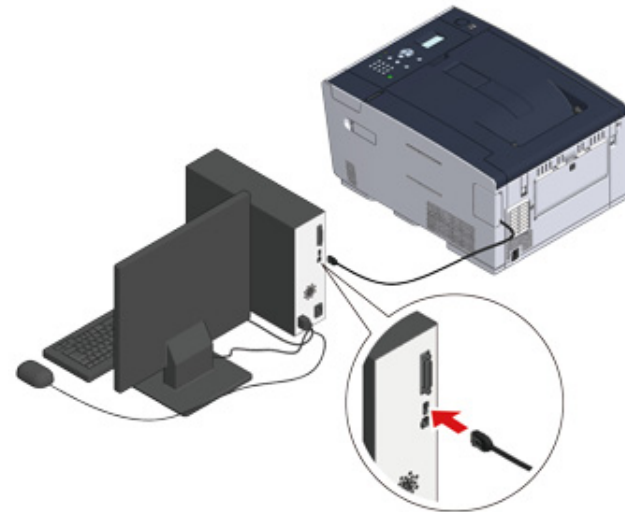

Go to the procedure to "[Loading Paper in the Tray](#)".

Loading Paper in the Tray

The procedure when loading paper in Tray 1 is used as an example.

The same procedure applies to Tray 2/3 (optional).

For details on available paper, see "[About Paper Types That Can be Loaded](#)".

- 1 Pull the paper cassette out.



- 2 Slide the paper guide (a) to the width of paper to be loaded.

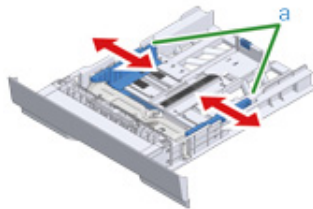

- 3 Slide the paper stopper (b) to the length of paper to be loaded.

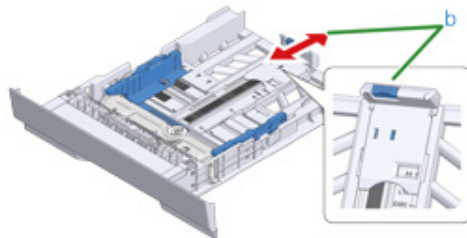

- 4 Fan a stack of paper well, and then align the edges of the paper.

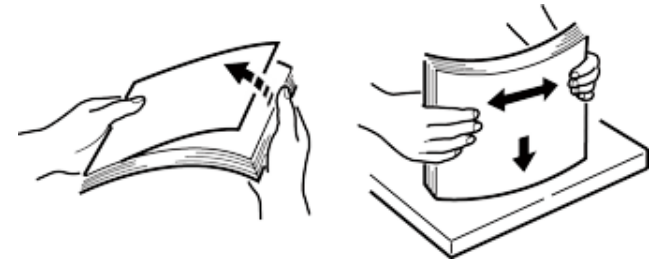

- 5 Load paper with the print side face down.



Do not load paper above the "▽" mark on the paper guide.

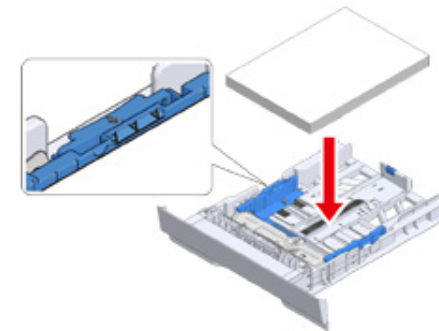

- 6 Secure the loaded paper with the paper guide.

- 7 Replace the paper cassette into the machine.
Push the paper cassette until it stops.



Setting Up This Machine

The first time the machine is turned on or when the settings are initialized, set up the machine with the necessary information.

- [Language Setup](#)
- [Setting Date and Time](#)
- [Setting the Administrator Password](#)
- [Network Settings](#)
- [Test Print](#)

Language Setup

The factory default display language is English. To change the display language to a language other than English, follow the steps below.

- 1 Press the ▼ button repeatedly to select [Setting] and press the ⏎ (Enter) button.
- 2 Press the ▲ button once to select [Admin Setup] and press the ⏎ (Enter) button.
- 3 Enter the administrator password, and then press the ⏎ (Enter) button.
The factory default administrator password is "999999".
Enter the first character of the password using the numeric keypad and press the ⏎ (Enter) button. Then enter the second character of the password using the numeric keypad and press the ⏎ (Enter) button. Enter the rest of the password in the same manner. When the password entry is complete, press the ⏎ (Enter) button.
- 4 Press the ▼ button repeatedly to select [Manage Unit] and press the ⏎ (Enter) button.
- 5 Press the ▲ or ▼ button repeatedly to select [Language Maintenance Setup] and press the ⏎ (Enter) button.
- 6 Check that [Select Language] is selected, and then press the ⏎ (Enter) button.
- 7 Press the ▲ or ▼ button repeatedly to select language you want to use and press the ⏎ (Enter) button.
- 8 Check that [*] is displayed on the left of the selected language.
- 9 Press the ⏪ (Back) button three times to go back to the [Admin Setup] screen.

Setting Date and Time

- 1 Press the ▼ button to select [Setting], and then press the ⏎ (Enter) button.
- 2 Press the ▲ button to select [Admin Setup] and press the ⏎ (Enter) button.
- 3 Enter the administrator password, and then press the ⏎ (Enter) button.
The factory default administrator password is "999999".
- 4 Press the ▲ or ▼ button to select [User Install] and press the ⏎ (Enter) button.
- 5 Check that [Time Zone] is selected, and then press the ⏎ (Enter) button.
- 6 Enter the setting value, and then press the ⏎ (Enter) button.
- 7 Check that [*] is displayed on the left of the set value.
- 8 Press the ◀ (Back) button to go back to the [User Install] screen.
- 9 Press the ▲ or ▼ button to select [Time Setup] and press the ⏎ (Enter) button.
- 10 Press the ▲ or ▼ button to select [Manual Setup] and press the ⏎ (Enter) button.
- 11 Press the ▲ or ▼ button or use the numeric keypad to enter the month, day, year and time, and then press the ⏎ (Enter) button.
- 12 The setting values are updated.
- 13 Press the ◀ (Back) button to go back to the [Ready To Print] screen.

Setting the Administrator Password

The factory default administrator password is "999999".

It is recommended to change the administrator password to enhance security. Set the administrator password using from 6 to 12 alphanumeric characters.

Be careful not to forget the set password.

- 1 Press the ▼ button to select [Setting], and then press the ⏎ (Enter) button.
- 2 Press the ▲ button to select [Admin Setup] and press the ⏎ (Enter) button.
- 3 Enter the administrator password, and then press the ⏎ (Enter) button.
The factory default administrator password is "999999".
- 4 Press the ▲ or ▼ button to select [Manage Unit] and press the ⏎ (Enter) button.
- 5 Press the ▲ or ▼ button to select [Admin Password] and press the ⏎ (Enter) button.
- 6 Enter a new password, and then press the ⏎ (Enter) button.
- 7 Enter the password again to confirm, and then press the ⏎ (Enter) button.
- 8 The setting value is updated and the screen returns to the [Admin Setup] screen.
- 9 Press the ◀ (Back) button to go back to the [Ready To Print] screen.

Network Settings

Since the network settings are required when using the machine, you are supposed to make the network as soon as possible.

The settings for a wired network connection is described in this section. For a wireless network connection, refer to "[Connecting to a Wireless LAN \(Only When the Wireless LAN Module is Mounted\)](#)".

- 1 Press the ▼ button to select [Setting], and then press the ⏎ (Enter) button.
- 2 Press the ▲ button to select [Admin Setup] and press the ⏎ (Enter) button.
- 3 Enter the administrator password, and then press the ⏎ (Enter) button.
The factory default administrator password is "999999".
- 4 Check that the wiring has correctly been finished.
- 5 Press the ▲ or ▼ button to select [Network Menu] and press the ⏎ (Enter) button.
- 6 Press the ▲ or ▼ button to select [Network Setup] and press the ⏎ (Enter) button.
- 7 Press the ▲ or ▼ button to select [Network Setting] and press the ⏎ (Enter) button.
- 8 Set an IP address. Press the ▲ or ▼ button to select [IP Address Set] and press the ⏎ (Enter) button.
- 9 Press the ▲ or ▼ button to select [Auto] and press the ⏎ (Enter) button.



When selecting [Manual], check the following values specified by your provider or network administrator.

IP Address

Subnet Mask

Default Gateway

DNS Server (Primary)

DNS Server (Secondary)

WINS Server (Primary)

WINS Server (Secondary)

For the [Manual] setting, press the ◀ (Back) button to go back to the [Network Setting] screen, and then enter the values one by one.

- 10 Press the ◀ (Back) button to go back to the [Ready To Print] screen.

Test Print

When the settings are complete, print a test page to check the settings.

- 1 Press the ▼ button to select [Setting], and then press the ↵ (Enter) button.
- 2 Press the ▲ button to select [Reports], and then press the ↵ (Enter) button.
- 3 Press the ▲ or ▼ button to select [Configuration] and press the ↵ (Enter) button.
- 4 When [Execute] is displayed, press the ↵ (Enter) button.
If you do not want to print a test page, press the ◀ (Back) button to cancel test print and return to the previous menu.
- 5 The screen returns to the [Ready To Print] screen.

Connecting to a Wireless LAN (Only When the Wireless LAN Module is Mounted)

- [Before Connecting to a Wireless LAN](#)
- [Enabling Wireless LAN Connection](#)
- [Connecting to an Access Point \(Infrastructure\)](#)
- [Connecting to the Machine Directly](#)

Before Connecting to a Wireless LAN



- Wireless(Infrastructure) and Wireless(AP Mode) cannot be enabled at the same time.
- If the machine is used in a wireless network environment, the machine does not enter Deep Sleep mode but enters Sleep mode.
- Do not place any electric products that emit weak radio waves (such as microwaves or digital cordless telephones) close to the machine.
- The communication speed of a wireless LAN connection may be slower than that of a wired LAN or USB connection depending on the environment. If you want to print big data such as a photo, it is recommended to print with a wired LAN or USB connection.

Connecting to an Access Point

Before connecting this machine to a wireless LAN access point, check the following.



- 1 Check if your wireless LAN access point matches the following requirements.
Standards: IEEE 802.11 a/b/g/n
Access method: Infrastructure mode

2 Check if the wireless LAN access point supports WPS.

If it does not support WPS, check the SSID and encryption key by referring to the instruction manual that is included in the wireless LAN access point or other documents.



- An SSID is also called a network name, ESSID or ESS-ID.
- An encryption key is also called a network key, security key, password, or Pre-shared Key.

Connecting to the Machine Directly

You can use the machine as a wireless access point to directly connect wireless devices (computers, tablets, smartphones, etc.). Check the following.

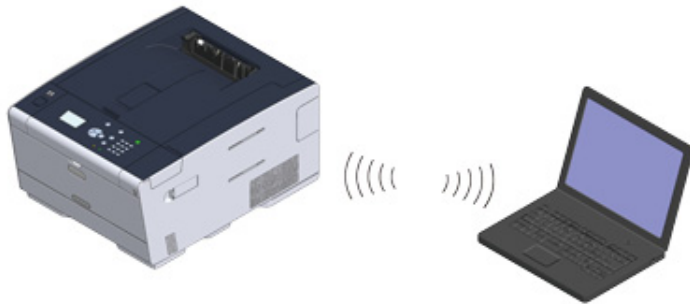

1 Check if your wireless devices match the following requirements.

Standards: IEEE 802.11 b/g/n

Security: WPA2-PSK(AES)

2 Check if your wireless devices support WPS-PBC (push button).



If you are not sure that the device supports WPS-PBC, connect manually after turning the machine on.

Enabling Wireless LAN Connection

Wireless LAN connection is disabled by default. To use the wireless LAN connection, enable Wireless in the Admin Setup.

- 1 Check that the machine is turned on.
- 2 Press the ▼ button repeatedly to select [Setting] and press the ⏎ (Enter) button.
- 3 Press the ▲ button once to select [Admin Setup] and press the ⏎ (Enter) button.
- 4 Enter the administrator password, and then press the ⏎ (Enter) button.



The factory default administrator password is "999999". If the administrator password is changed, enter the updated password.

- 5 Press the ▲ button to select [User Install] and press the ⏎ (Enter) button.
- 6 Press the ▲ button to select [Wireless Module], and then press the ⏎ (Enter) button.
- 7 Press the ▲ button to select [Enable] and press the ⏎ (Enter) button.
- 8 Check that [*] is displayed on the left of [Enable], and then press the ⏎ (Enter) button.
- 9 Press the ◀ (Back) button until the home screen is displayed.
- 10 Press the power button to turn the machine off.
- 11 Go to "Connecting to an Access Point".

Connecting to an Access Point (Infrastructure)



- Install this machine in a place with a good view and near a wireless access point. (We suggest that the distance between the machine and the wireless device be 30 m or less.)
- If there is metal, aluminum sash, or a reinforced concrete wall between the machine and wireless LAN access points, connections may be harder to be established.
- Outdoor use of IEEE802.11a (W52/W53) is prohibited by the Radio Law. Use IEEE802.11a (W52/W53) only indoors.

• Connecting with WPS

If a wireless LAN access point supports WPS, you can connect to the wireless LAN with the WPS button.

• Selecting a Wireless LAN Access Point from the Operator Panel to Connect

If a wireless access point does not support WPS, you can specify a wireless LAN access point you want to use from the wireless LAN access points that the printer detects to establish a connection.

• Setting from the Operator Panel Manually to Connect

Set the wireless LAN access point information (the SSID, encryption method, and encryption key) manually to connect to the wireless LAN.



Connecting with WPS



If a wireless LAN access point supports WPS, you can easily connect to the wireless LAN with the easy setup button (WPS button).

- 1 Check the position of the WPS button by referring to the instruction manual that is included in a wireless LAN access point or other document.
- 2 Check that the wireless LAN access point starts and is operating properly.
- 3 Turn the machine on.





Check that the screen displays "Do you want to Set-up wireless?" and [Yes] is selected, Press the  (Enter) button and go to step 6.



- 4 Press the  button repeatedly to select [Setting] and press the  (Enter) button.

- 5 Press the  button repeatedly to select [Wireless(Infrastructure) Setting] and press the  (Enter) button.

- 6 Enter the administrator password, and then press the  (Enter) button.
The factory default administrator password is "999999". If the administrator password is changed, enter the updated password.
The "It is not possible to use the Wireless(AP Mode) at the same time." message is displayed for approximately five seconds.

- 7 Select [Enable] and then press the  (Enter) button.

- 8 If your environment requires to set IP address, etc. manually, press the  button to select [Network Setting], and then press the  (Enter) button. If you do not need to set manually, go to step 12.

- 9 Press the  button to select [Manual] on the [Wireless (infrastructure) settings] screen, and then press the  (Enter) button.



- 10 Follow the onscreen instructions to set the IP address, subnet mask, default gateway, and DHCP v6.



Ask your provider or network administrator about the setting value.

- 11 Select [Close] when the Wireless (infrastructure) settings are complete, and then press the  (Enter) button.

The screen switches automatically in a while without pressing [Close].

- 12 Press the  button repeatedly to select [Automatic Setup(WPS)] and press the  (Enter) button.

- 13 Press the  button to select [WPS-PBC] and press the  (Enter) button.

- 14 When [Pushbutton method] is displayed, select [Yes] and press the  (Enter) button.

The machine starts searching for wireless LAN access points. The "Running pushbutton method..." message is displayed on the screen. Press and hold the WPS button on the wireless LAN access point while the message is displayed.



You cannot operate the panel when WPS is in progress.

When [WPS connection successful.] is displayed, select [Close] and press the  (Enter) button.



- When [Connection failed. Timeout] is displayed, repeat the procedure from step 14.
- [Overlap] is displayed when multiple WPS push buttons are pressed almost at the same time at two or more wireless LAN access points and connection is not established. Wait for a while, and then try again.

15 If the antenna mark is displayed at the top right of the home screen, the connection is established correctly.



The antenna mark may not be displayed on some screens.

Selecting a Wireless LAN Access Point from the Operator Panel to Connect

If a wireless LAN access point does not support WPS, you can specify a wireless LAN access point you want to use from the wireless LAN access points that the machine detects to establish a connection. In such a case, you must enter an encryption key.

1 Check the SSID and encryption key by referring to the instruction manual that is included in a wireless LAN access point or other documents, and write the information down.



WPA-EAP and WPA2-EAP cannot be set on the operator panel. Set them from the Web page of this machine.

 [Open the Web Page of This Machine \(Advanced Manual\)](#)





- An SSID is also called a network name, ESSID or ESS-ID.
- An encryption key is also called a network key, security key, password or Pre-shared Key.



2 Check that the wireless LAN access point starts and is operating properly.

3 Turn the machine on.



Check that the screen displays "Do you want to Set-up wireless?" and [Yes] is selected, Press the  (Enter) button and go to step 6.

4 Press the  button repeatedly to select [Setting] and press the  (Enter) button.



5 Press the  button repeatedly to select [Wireless(Infrastructure) Setting] and press the  (Enter) button.



6 Enter the administrator password, and then press the  (Enter) button.

The factory default administrator password is "999999". If the administrator password is changed, enter the updated password.

The "It is not possible to use the Wireless(AP Mode) at the same time." message is displayed for approximately five seconds.

7 Select [Enable] and then press the  (Enter) button.

8 If your environment requires to set IP address, etc. manually, press the  button to select [Network Setting], and then press the  (Enter) button. If you do not need to set manually, go to step 12.

9 Press the  button to select [Manual] on the [Wireless (infrastructure) settings] screen, and then press the  (Enter) button.

10 Follow the onscreen instructions to set the IP address, subnet mask, default gateway, and DHCP v6.





Ask your provider or network administrator about the setting value.

11 Select [Close] when the Wireless (infrastructure) settings are complete, and then press the  (Enter) button.



The screen switches automatically in a while without pressing [Close].

12 Press the  button repeatedly to select [Wireless Network Selection] and press the  (Enter) button.

The machine starts searching for wireless LAN access points. Wait for a while.

13 Select a wireless LAN access point to connect, and then press the  (Enter) button.



If only [Manual Setup] is displayed, or the SSID of the wireless LAN access point you want to use is not included in the list, set by following the procedure in "[Setting from the Operator Panel Manually to Connect](#)".

The encryption key entry screen that is suitable for the encryption method of the selected wireless LAN access point is displayed.

14 Enter the encryption key, and then press the (Enter) button.



The encryption key varies depending on the wireless LAN access point or security.

- If the [WPA Pre-shared Key] is displayed

Item	Description
Security	WPA/WPA2-PSK
Encryption key	Enter the Pre-shared Key.

- If the [WEP Key] is displayed

Item	Description
Security	WEP
Encryption key	Enter the WEP key.

- If neither of the above two cases is applied

Item	Description
Security	Disable
Encryption key	No entry is required.

15 If the displayed SSID is the same as the SSID that you checked in step 1, select [Yes], and then press the (Enter) button.

When "Connection successful." is displayed, select [Close], and then press the (Enter) button.

If "Connection failed." is displayed, repeat the procedure from step 5.

16 If the antenna mark is displayed at the top right of the home screen, the connection is established correctly.



The antenna mark may not be displayed on some screens.

Setting from the Operator Panel Manually to Connect

Set the wireless LAN access point information (the SSID, encryption method and encryption key) manually to connect to the wireless LAN.

- 1 Check the SSID, encryption key, and encryption method by referring to the instruction manual that is included in a wireless LAN access point or other documents, and write the information down.



If the encryption method is WPA-EAP and WPA2-EAP, set from the Web page of this machine.

For details, open the Web page of this machine and click [Admin Setup] > [Network] > [Wireless Setting] > [Manual Setup].

[Open the Web Page of This Machine \(Advanced Manual\)](#)



- An SSID is also called a network name, ESSID, or ESS-ID.
- An encryption key is also called a network key, security key, password, or Pre-shared Key.

- 2 Check that the wireless LAN access point starts and is operating properly.

- 3 Turn the machine on.



Check that the screen displays "Do you want to Set-up wireless?" and [Yes] is selected, Press the (Enter) button and go to step 6.

- 4 Press the button repeatedly to select [Setting] and press the (Enter) button.

- 5 Press the button repeatedly to select [Wireless(Infrastructure) Setting] and press the (Enter) button.

- 6 Enter the administrator password, and then press the (Enter) button.

The factory default administrator password is "999999". If the administrator password is changed, enter the updated password.

The "It is not possible to use the Wireless(AP Mode) at the same time." message is displayed for approximately five seconds.

- 7 Select [Enable] and then press the (Enter) button.

8 If your environment requires to set IP address, etc. manually, press the ▼ button to select [Network Setting], and then press the ↵ (Enter) button. If you do not need to set manually, go to step 12.

9 Press the ▼ button to select [Manual] on the [Wireless (infrastructure) settings] screen, and then press the ↵ (Enter) button.

10 Follow the onscreen instructions to set the IP address, subnet mask, default gateway, and DHCP v6.



Ask your provider or network administrator about the setting value.

11 Select [Close] when the Wireless (infrastructure) settings are complete, and then press the ↵ (Enter) button.



The screen switches automatically in a while without pressing [Close].

12 Press the ▼ button repeatedly to select [Wireless Network Selection] and press the ↵ (Enter) button.

The machine starts searching for wireless LAN access points. Wait for a while.

13 Select [Manual Setup], and then press the ↵ (Enter) button.

14 Enter the SSID you checked in step 1, and then press the ↵ (Enter) button.



The SSID is case sensitive. Enter the SSID correctly.

15 Select the encryption method you checked in step 1, and then press the ↵ (Enter) button.



The encryption key varies depending on the wireless LAN access point or security.

16 The procedure depends on the encryption method you selected in step 15.

If you selected [WPA/WPA2-PSK], select [TKIP/AES], and then press the ↵ (Enter) button. Enter the Pre-shared Key afterward and select [Next].

If you selected [WPA2-PSK], select [AES], and then press the ↵ (Enter) button. Enter the Pre-shared Key afterward and select [Next].

If you selected [WEP], enter the WEP Key, and press [Next].

17 If the displayed value is the same as the value that you checked in step 1, select [Yes], and then press the ↵ (Enter) button.



It takes approximately 30 seconds for the machine to detect the wireless LAN access point.

When the screen indicates that connection is established, select [Close] and press the ↵ (Enter) button.

If the screen indicates that connection failed, press [Close] and go back to step 5.

18 If the antenna mark is displayed at the top right of the home screen, the connection is established correctly.



The antenna mark may not be displayed on some screens.

- **If the wireless LAN connection is unstable**

If the wireless LAN connection is unstable, read the cautions in "[Before Connecting to a Wireless LAN](#)", and then change the positions of the machine and wireless LAN access point. If you cannot find a solution even after reading the cautions, bring the machine and the wireless LAN access point close to each other.

Connecting to the Machine Directly

Wireless LAN (AP mode) directly connects wireless devices (computers, tablets, smartphones, etc.) to the machine without using a wireless LAN access point.



- If there is metal, aluminum sash, or a reinforced concrete wall between the machine and wireless devices, connections may be harder to be established.
- Up to four devices can be connected to the machine via the wireless LAN (AP mode). The fifth device will be rejected.

• Automatic connection (push-button)

If your wireless devices support WPS-PBC (push button), you can connect to the wireless LAN (AP mode) with the WPS button.

• Manual Setup

If your wireless devices do not support WPS-PBC (push button), you can enter [SSID] and [Password] of the machine in your wireless devices to connect to the wireless LAN (AP mode).

Automatic connection (push-button)

If your wireless devices support WPS-PBC (push button), you can connect to the wireless LAN (AP mode) with the WPS button.

1 Confirm the position of the WPS button on your wireless device by the manual attached to the device.

2 Turn the machine on.



If the "Do you want to Set-up wireless?" message appears, select [No (Do not show next time)].

3 Press the ▼ button to select [Setting] and press the ⏩ (Enter) button.

4 Press the ▲ button to select [Admin Setup] and press the ⏩ (Enter) button.

5 Enter the administrator password, and then press the ⏩ (Enter) button.

The factory default administrator password is "999999". If the administrator password is changed, enter the updated password.

6 Press the ▼ button to select [Network Menu] and press the ⏩ (Enter) button.

7 Press the ▼ button to select [Network Setup] and press the ⏩ (Enter) button.

8 Press the ▼ button to select [Wireless(AP Mode) Setting] and press the ⏩ (Enter) button.

The "It is not possible to use the Wireless(infrastructure) at the same time." message is displayed for approximately five seconds.

9 Select [Enable] and then press the ⏩ (Enter) button.

10 Press the ▼ button to select [Automatic Setup (Pushbutton)] and press the ⏩ (Enter) button.

11 When [Pushbutton method] is displayed, select [Yes].

12 Start the WPS-PBC (push button) operation on your wireless device to connect to the machine.

When the following screen appears, the setup of the wireless LAN is completed.

In case of connection failure, follow the steps in "Manual Setup" to try again.

Manual Setup

If your wireless devices do not support WPS-PBC (push button), you can enter [SSID] and [Password] of the machine in your wireless devices to connect to the wireless LAN.

1 Turn the machine on.



If the "Do you want to Set-up wireless?" message appears, select [No (Do not show next time)].

2 Press the ▼ button to select [Setting] and press the ⏩ (Enter) button.

3 Press the ▲ button to select [Admin Setup] and press the ⏩ (Enter) button.

4 Enter the administrator password, and then press the ⏩ (Enter) button.
The factory default administrator password is "999999".

5 Press the ▼ button to select [Network Menu] and press the ⏩ (Enter) button.

6 Press the ▼ button to select [Network Setup] and press the ⏩ (Enter) button.

- 7 Press the ▼ button to select [Wireless(AP Mode) Setting] and press the ↵ (Enter) button.
The "It is not possible to use the Wireless(AP Mode) at the same time." message is displayed for approximately five seconds.
- 8 Select [Enable] and then press the ↵ (Enter) button.
- 9 Press the ▼ button to select [Manual Setup] and press the ↵ (Enter) button.
- 10 Check the [SSID] and [Password] of the machine.
- 11 Enter the [SSID] and [Password] that you checked in step 10 to connect the machine and your wireless device.

Installing a Driver and Software to a Computer

Install the printer driver from the "Software DVD-ROM" to the computer.

Other utility software can be installed at the same time.

- [For Windows](#)
- [For Mac OS X](#)

For Windows

Connect the machine and computer via a network or USB cable and start installing.



Check the status of this machine before installing.

- This machine is turned on.
- For network connection, this machine is connected to the network via a LAN cable and required information such as IP address is already set.

- 1 Insert the included "Software DVD-ROM" into a computer.
- 2 When [Auto Play] is displayed, click [Run setup.exe].

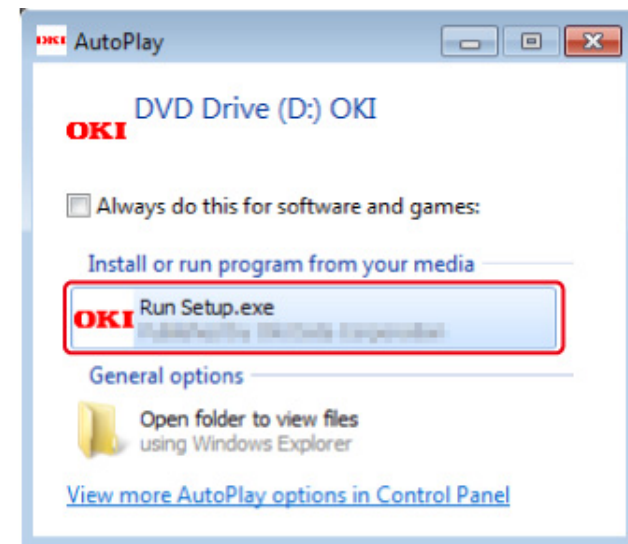

If the [User Account Control] dialog box is displayed, click [Yes].

- 3 Select a language from the drop-down list.
- 4 Read the license agreement, and then click [Accept].
- 5 Read [Environment advice], and then click [Next].

- 6 Select [Network] or [USB connection] in accordance to the connection method of the machine and computer, and then click [Next].

If the [Windows Security Alert] dialog box is displayed, click [Allow access].

- 7 Select the model name of the machine, and then click [Next].



- 8 Click [Install Optional Software].

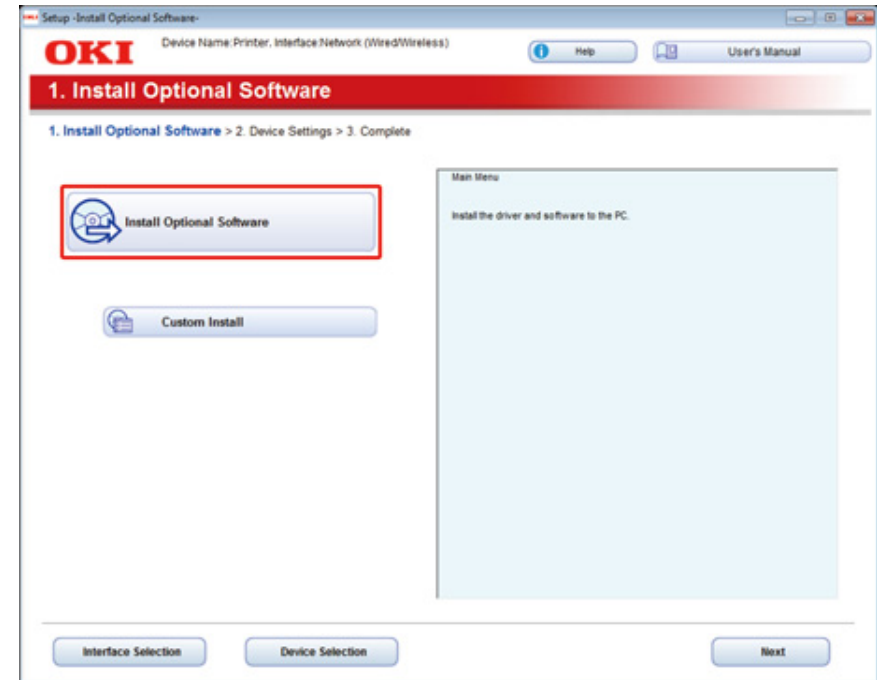

Installation starts.



The following software is installed.

- PCL6 Printer Driver (Including Network Extension and Color Swatch Utility)
- FAQ

Install other software from Custom Install.

 Installing Software (Advanced Manual)

- 9 Make sure that the software is successfully installed, and then click [Printing Test].

Select the printer for test printing, and then click [Printing Test].

Make sure that the test printing was successful, and then click [OK].

10 Click [Complete].

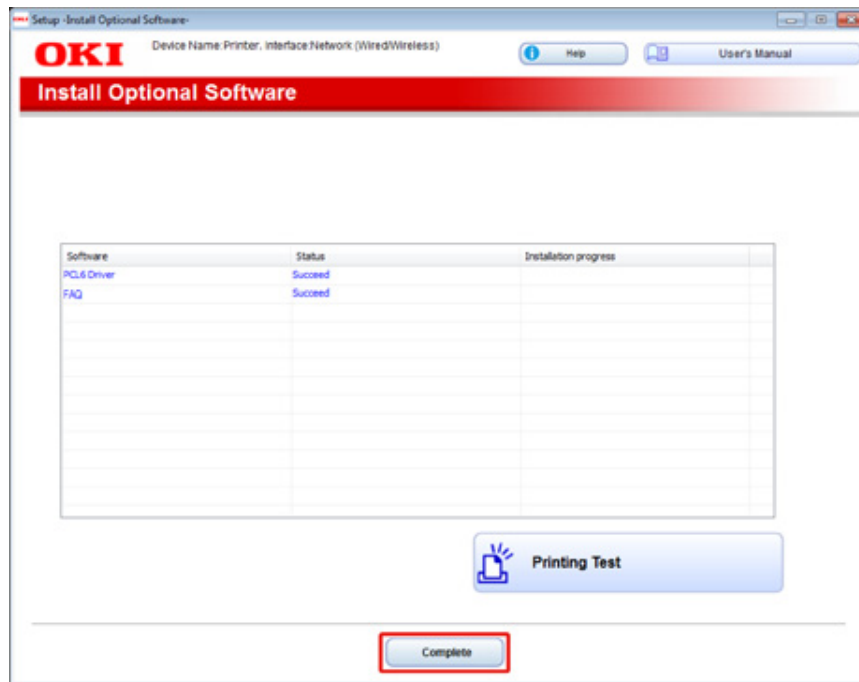

11 Click [Next].

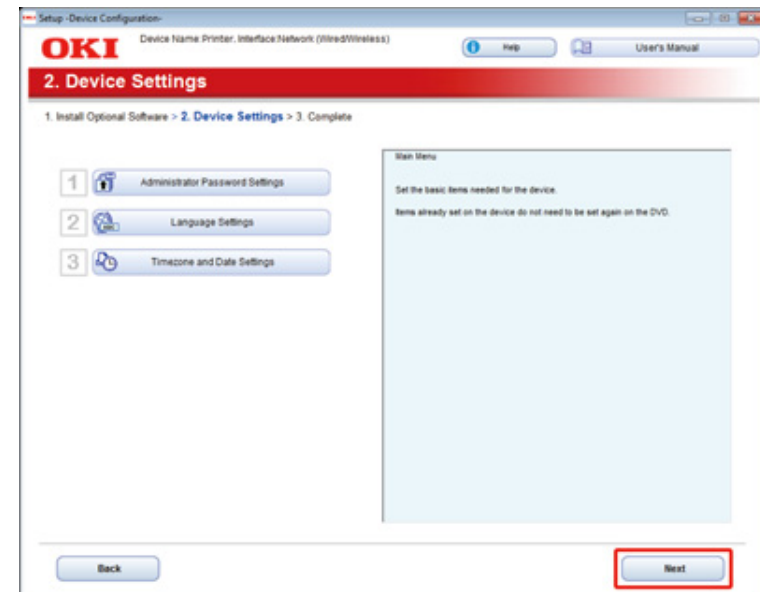

If the following dialog box is displayed, click [Yes].

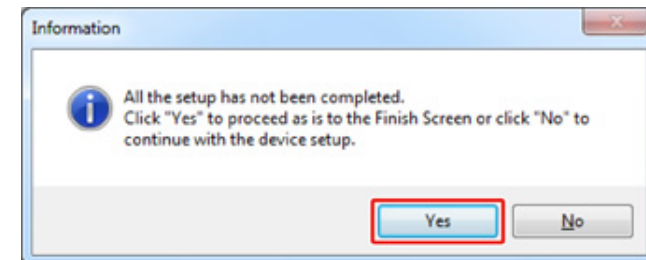

12 Click [Exit].

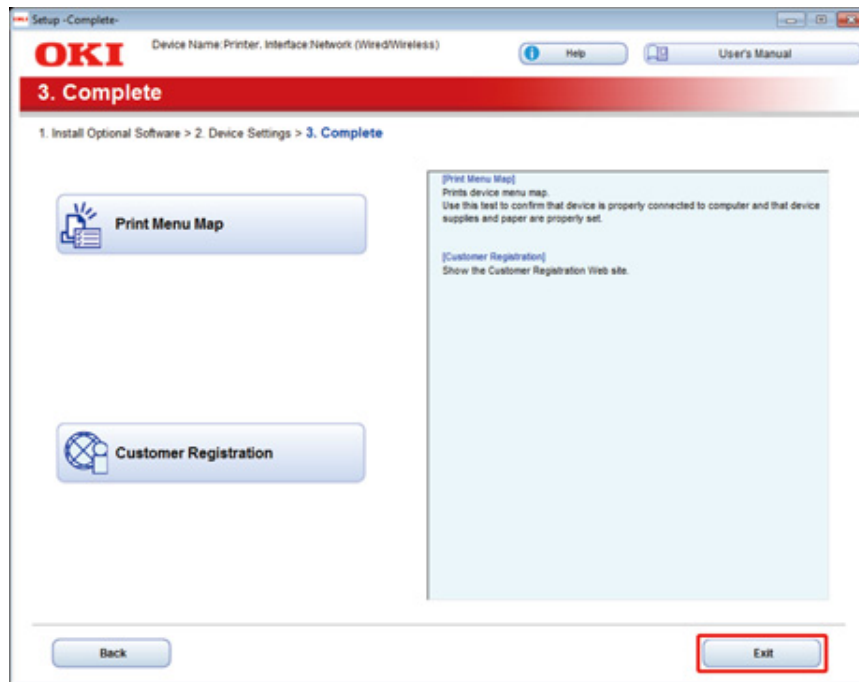

For Mac OS X

This section describes how to install the PS printer driver.

For installation of utilities, see the following.

 [Installing Software \(Advanced Manual\)](#)

When the installation is complete, print a test page in step 15.

- 1 Make sure that the machine and a computer are connected and the machine is turned on.
- 2 Insert the "Software DVD-ROM" into a computer.
- 3 Double-click the [OKI] icon on the desktop.
- 4 [Drivers] > [PS] > Double-click [Installer for OSX].
- 5 Enter the administrator password, and then click [OK].
Follow the on-screen instructions to complete the installation.
- 6 Select [System Preferences] from the Apple menu.
- 7 Click [Printers & Scanners].

- 8 Click [+].
Select [Add Printer or Scanner...] when the menu is displayed.

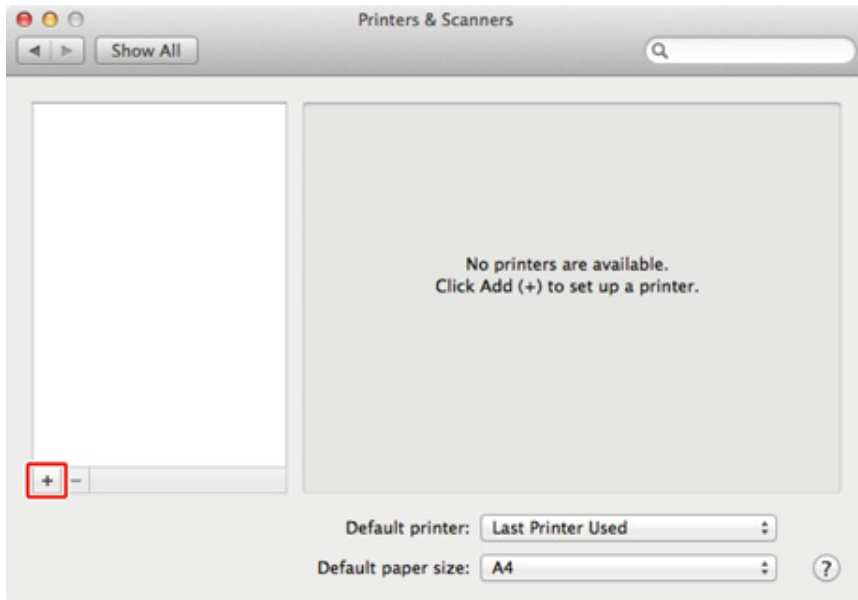

- 9 Click [Default].
- 10 Select the machine, and then select [OKI C532 PS] in [Use].

Types of Names	Displayed in the Connection	Methods List
Network	OKI-C532 (last 6 digits of MAC address)	Bonjour
USB	OKI DATA CORP C532	USB



To change the name, enter a new name into [Name:].

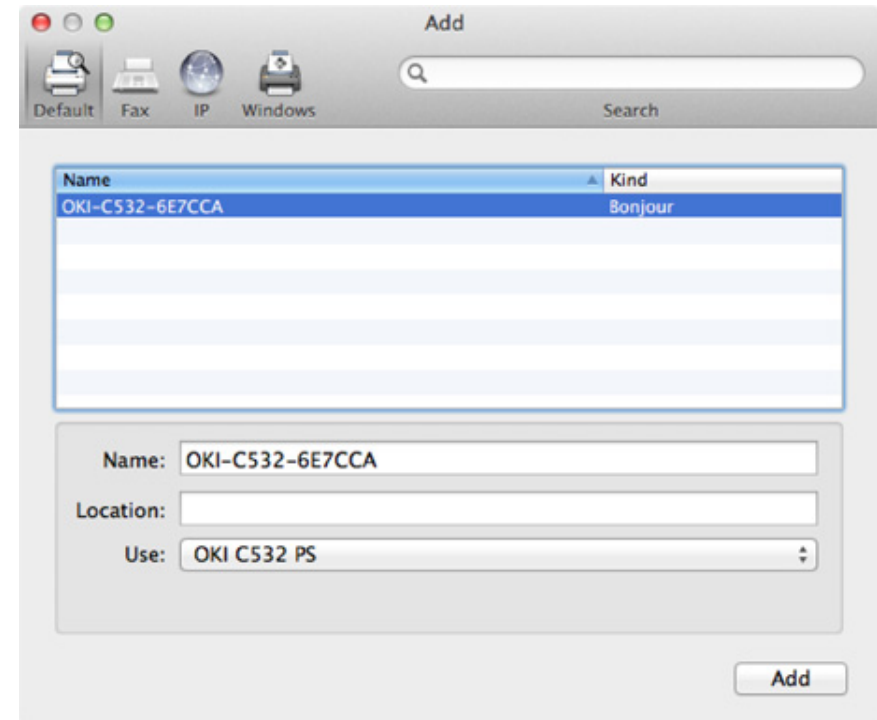

- 11 Click [Add].
- 12 If the confirmation screen for optional equipment appears, click [OK].

- 13 Make sure that the machine is added to [Printers] and [OKI C532 PS] is displayed for [Kind].

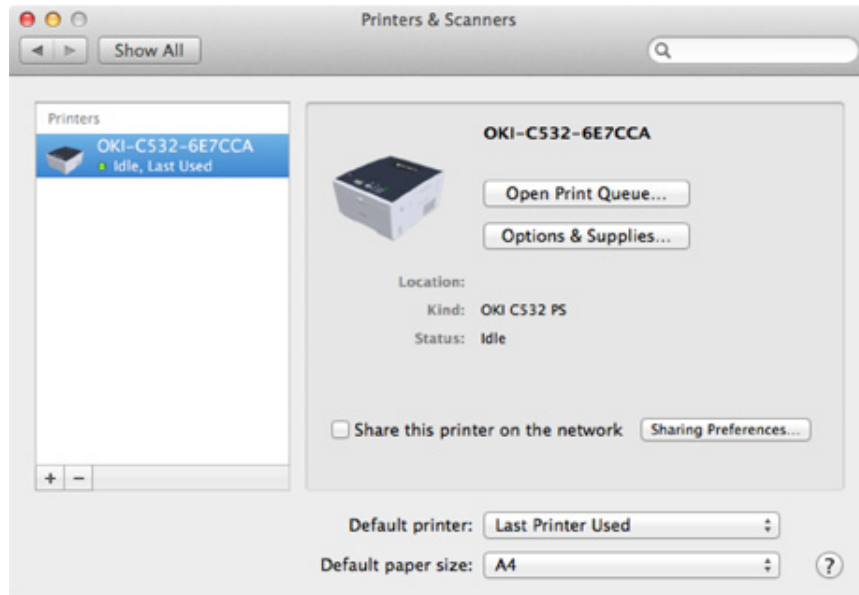

If [OKI C532 PS] is not displayed for [Kind] correctly, click [-], delete the machine from [Printers], and then newly perform steps 8 to 12.

- 14 Click [Open Print Queue...].
- 15 Select [Print Test Page] from the [Printer] menu.

3

Basic Operations

Names of Components

Basic Operations on the Operator Panel

Turning the Machine On or Off

Loading Paper

This section describes basic operations of this machine.

Names of Components

The chapter describes the name of each component.

- [Front View](#)
- [Rear View](#)
- [Inside of the machine](#)

Front View

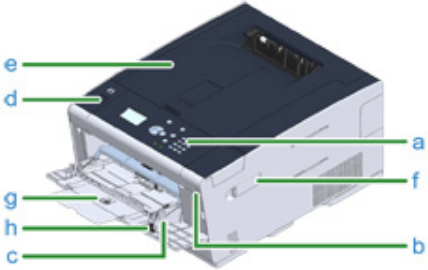

Symbol	Name
a	Operator panel Basic Operations on the Operator Panel
b	USB port
c	MP tray (Multipurpose tray)
d	Open button
e	Output tray (top cover)
f	Wireless LAN module cover
g	Paper supporter
h	Envelope lever (Use this when printing on envelopes. For instructions, refer to "Printing on Envelopes (Advanced Manual)".)

Rear View

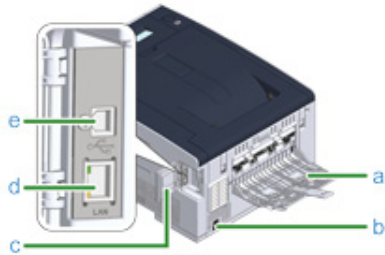

Symbol	Name
a	Rear output tray
b	Power connector
c	Interface connector cover
d	Network interface connector
e	USB interface connector

Inside of the machine

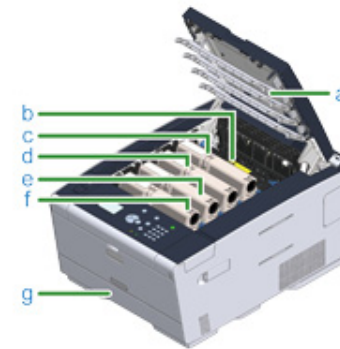

Symbol	Name
a	LED head
b	Fuser unit
c	Toner cartridge / Image drum (Y: yellow)
d	Toner cartridge / Image drum (M: magenta)
e	Toner cartridge / Image drum (C: cyan)
f	Toner cartridge / Image drum (K: black)
g	Tray 1

Basic Operations on the Operator Panel

This section describes the operator panel of the machine.

- Names and Functions
- Entering with the Numeric Keypad

Names and Functions

This section describes the names and functions of components on the operator panel.

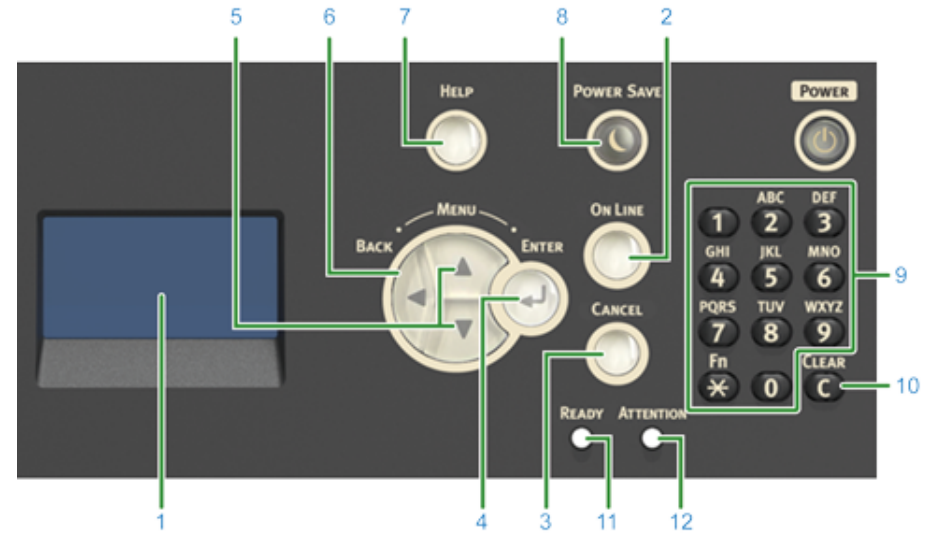

No.	Name	Function
1	Display screen	Indicates the printer status or instructions.
2	ONLINE	Switches ONLINE and OFFLINE.
3	CANCEL	Cancels the current print job immediately.
4	ENTER	Sets the highlighted item.
5	▼, ▲	<ul style="list-style-type: none"> • Displays menu items. • Selects a menu item or scroll through the display screen.
6	BACK	Returns to the previous screen.
7	HELP	Displays Help screen. To close the Help screen, press the (HELP) button again or press the (BACK) or (CANCEL) button.
8	POWER SAVE	<ul style="list-style-type: none"> • Enters or exits Power Save mode. • Exits Sleep mode. <p>Lights in green in Power Save mode and flashes in green in Sleep mode.</p>
9	Numeric keypad	<ul style="list-style-type: none"> • Enter numbers. • Enter alphabet characters and symbols. <p>Use the numeric keypad to enter a password.</p>
10	CLEAR	Clears the entered value.
11	READY indicator	Lights in green in ONLINE mode and turns off in OFFLINE mode.
12	ATTENTION indicator	Lights or flashes in orange if an error occurs on the machine.

Entering with the Numeric Keypad

Use to enter numbers or alphabet characters. Available characters and how to switch types of characters are shown below.

Number	
<1>	1
<2>	a → b → c → 2 → a
<3>	d → e → f → 3 → d
<4>	g → h → i → 4 → g
<5>	j → k → l → 5 → j
<6>	m → n → o → 6 → m
<7>	p → q → r → s → 7 → p
<8>	t → u → v → 8 → t
<9>	w → x → y → z → 9 → w
<0>	0

Press the **C** (CLEAR) button to delete a character when entering a password.



To enter "abc"

Press <2> → (ENTER) → <2> → <2> → (ENTER) → <2> → <2> → <2> → (ENTER).

Turning the Machine On or Off

This section describes how to turn on and off the machine.

- [Turning the Machine On](#)
 - [Turning the Machine Off](#)
-

Turning the Machine On

- 1 Press the power switch for approximately a second.



When the machine is turned on, the power switch LED lamp is lit.



- 2 The standby screen appears when the machine is ready.

Turning the Machine Off



- Check that the machine is not receiving data before shutting down.
- Press and hold the power switch for 5 seconds or more to force shut down the machine. Use this method only if a problem occurs.

For troubleshooting of this machine, see "[Troubleshooting](#)".

- 1 Press the power switch for approximately a second.



The "Shutting down. Please wait. Printer will turn off automatically." message is displayed on the display screen, and the power switch LED lamp flashes at approximately one-second intervals.

After a while, the machine automatically turns off, and the power switch LED lamp goes out.

What You Should Do If You Do Not Use This Machine for an Extended Period of Time

If you do not use this machine for an extended period of time due to holidays, trips, or other reasons, unplug the power cord from the outlet.



This machine does not have functional failures if the power cord is unplugged for an extended period of time (four weeks or more).

Loading Paper

This chapter describes various information about paper that can be loaded in a paper tray of this machine.

To set paper type and weight, press the ▲ ▼ buttons on the operator panel to select [Setting] > [Paper Setup] and select the tray you want to use, and then select [Media Type] or [Media Weight].

- [About Paper Types That Can be Loaded](#)
- [Loading Paper in Tray 1/2/3](#)
- [Loading Paper in the MP Tray](#)
- [Paper storage](#)

About Paper Types That Can be Loaded

Available paper types

To perform high-quality printing, be sure to use the supported paper types that satisfy requirements, such as material, weight, or paper surface finishing. Use digital photo print paper.

If you print on paper that is not recommended by OKI, check the print quality and the movement of the paper thoroughly in advance to ensure that there are no problems.

• Plain paper

Paper type	Paper size (mm) (Values in brackets are inch sizes.)	Paper weight
A4	210 x 297	64 to 220 g/m ² (17 to 58 lb)
A5	148 x 210	
A6	105 x 148	For duplex printing, 64 to 176 g/m ² (17 to 47 lb)
B5	182 x 257	
B6	128 x 182	 If you set paper that is 148 mm (5.8 inches) wide or narrower, printing becomes slower.
B6 Half	64 x 182	
Letter	215.9 x 279.4 (8.5 x 11)	
Legal13	215.9 x 330.2 (8.5 x 13)	
Legal13.5	215.9 x 342.9 (8.5 x 13.5)	
Legal14	215.9 x 355.6 (8.5 x 14)	
Executive	184.2 x 266.7 (7.25 x 10.5)	
Statement	(5.5 x 8.5)	
8.5" SQ	(8.5 x 8.5)	
Folio	210 x 330	
16K(184x260mm)	184 x 260	
16K(195x270mm)	195 x 270	
16K(197x273mm)	197 x 273	
Index Card	(3 x 5)	
4x6 inch	(4 x 6)	
5x7 inch	(5 x 7)	
Custom	Width: 64 to 216 Length: 90 to 1321	64 to 220 g/m ² (17 to 58 lb)

• Envelope

Paper type	Paper size (mm) (Values in brackets are inch sizes.)	Paper weight
Com-9 Envelope	98.4 x 190.5 (3.875 x 7.5)	Envelopes must be made of paper of 85 g/m ² (24 lb), and their flaps must be folded.
Com-10 Envelope	98.4 x 225.4 (3.875 x 8.875)	
Monarch Envelope	104.8 x 241.3 (4.125 x 9.5)	
DL Envelope	110 x 220 (4.33 x 8.66)	
C5 Envelope	162 x 229 (6.4 x 9)	

• Label

Paper type	Paper size (mm) (Values in brackets are inch sizes.)	Paper weight
A4	210 x 297	0.1 to 0.2 mm
Letter	215.9 x 279.4 (8.5 x 11)	

• Other type of paper

Paper type	Paper size (mm) (Values in brackets are inch sizes.)	Paper weight
Partly-printing paper	Subject to plain paper	64 to 220 g/m ² (17 to 58 lb)
Color paper	Subject to plain paper	64 to 220 g/m ² (17 to 58 lb)

About Paper Sizes, Weight, and Number of Sheets That Can be Loaded

Available paper sizes and types, and tray capacity are as follows.

• Tray 1

Available paper size	Tray capacity	Paper weight
A4 A5 A6*1 B5 B6*1 Letter Legal13 Legal13.5 Legal14 Executive Statement*1 8.5" SQ Folio 16K(184x260mm) 16K(195x270mm) 16K(197x273mm) Custom size*2	250 sheets (if paper weight is 80 g/m ²)	Light (64 to 74 g/m ²) Medium Light (75 to 82 g/m ²) Medium (83 to 90 g/m ²) Medium Heavy (91 to 104 g/m ²) Heavy (105 to 120 g/m ²) Ultra Heavy1 (121 to 176 g/m ²)

*1 Paper cannot be used for duplex printing.

*2 Width: 100 to 216 mm (3.9 to 8.5 inches), Length: 148 to 356 mm (5.8 to 14 inches)

• Tray 2/3 (Optional)

Available paper size	Tray capacity	Paper weight
A4 A5 B5 Letter Legal13 Legal13.5 Legal14 Executive 8.5" SQ Folio 16K(184x260mm) 16K(195x270mm) 16K(197x273mm) Custom size*1	530 sheets (if paper weight is 80 g/m ²)	Light (64 to 74 g/m ²) Medium Light (75 to 82 g/m ²) Medium (83 to 90 g/m ²) Medium Heavy (91 to 104 g/m ²) Heavy (105 to 120 g/m ²) Ultra Heavy 1 (121 to 176 g/m ²)

*1 Width: 148 to 216 mm (5.8 to 8.5 inches), Length: 210 to 356 mm (8.3 to 14 inches)

• **MP Tray**

Available paper size	Tray capacity	Paper weight
A4	100 sheets	Light
A5	(if paper weight is 80 g/m ²)	(64 to 74 g/m ²)
A6 ^{*1}	10 sheets (envelopes)	Medium Light
B5		(75 to 82 g/m ²)
B6 ^{*1}		Medium
B6 Half ^{*1}		(83 to 90 g/m ²)
Letter		Medium Heavy
Legal13		(91 to 104 g/m ²)
Legal13.5		Heavy
Legal14		(105 to 120 g/m ²)
Executive		Ultra Heavy1
Statement ^{*1}		(121 to 176 g/m ²)
8.5" SQ		Ultra Heavy2
Folio		(177 to 220 g/m ²)
16K(184x260mm)		
16K(195x270mm)		
16K(197x273mm)		
Index Card ^{*1}		
4x6 inch ^{*1}		
5x7 inch ^{*1}		
Custom size ^{*2}		
Com-9 Envelope ^{*1}		
Com-10 Envelope ^{*1}		
Monarch Envelope ^{*1}		
DL Envelope ^{*1}		
C5 Envelope ^{*1}		

*1 Paper cannot be used for duplex printing.

*2 Width: 64 to 216 mm (2.5 to 8.5 inches), Length: 90 to 1,321 mm (3.5 to 52 inches)

Recommended Paper

The machine supports a variety of print media, including a range of paper weights and sizes. This section describes how to choose and use media. To obtain the best performance, use 75 to 90 g/m² plain paper that is designed for use in copiers and laser printers. Use of heavily embossed or very rough textured paper is not recommended. Pre-printed stationery can be used, but the ink must not offset when exposed to the high fuser temperatures used in the printing process.

• **Envelopes**

Envelopes must be free from twists, curls or other deformations. The envelopes must also be of the rectangular flap type, with glue that remains intact when subjected to hot roll pressure fusing in the machine. Window envelopes are not suitable.

• **Labels**

Labels must be of the type recommended for use in copiers and laser printers, in which the base carrier page is entirely covered by labels. Other types of label stocks may damage the machine due to the labels peeling off during the printing process.

Loading Paper in Tray 1/2/3

The procedure when loading paper in Tray 1 is used as an example, and the same procedure applies to Tray 2/3 (optional).

- 1 Pull the paper cassette out.



- 2 Slide the paper guide (a) to the width of paper to be loaded.

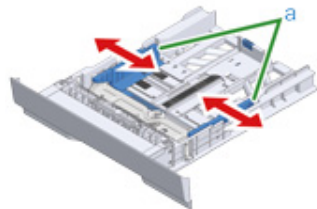

- 3 Slide the paper stopper (b) to the length of paper to be loaded.

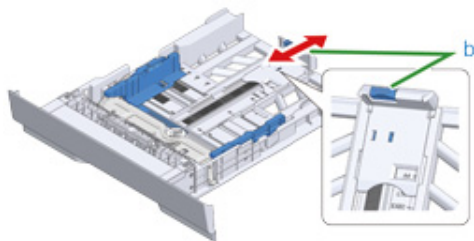

- 4 Fan a stack of paper well, and then align the edges of the paper.

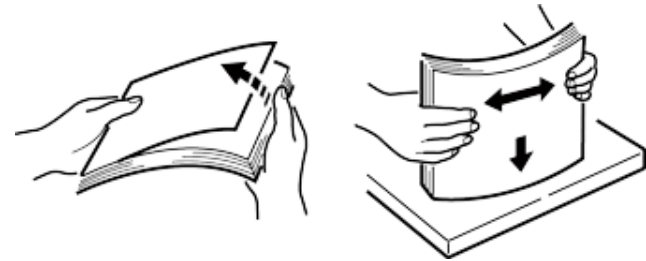

- 5 Load paper with the print side face down.



Do not load paper above the "▽" mark on the paper guide.

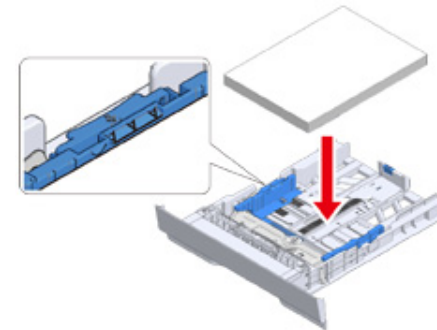

- 6 Secure the loaded paper with the paper guide.

- 7 Push the paper cassette until it stops.



- 8 Press the ▲ or ▼ button on the operator panel to select [Setting] and press the ⏎ (ENTER) button.

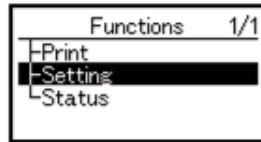

- 9 Select [Paper Setup], and then press the ⏎ (ENTER) button.

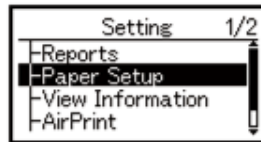

- 10 Select the tray in which paper is loaded, and then press the ⏎ (ENTER) button.

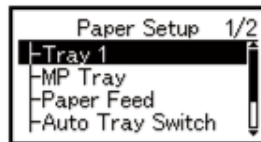

- 11 Set [Paper Size].

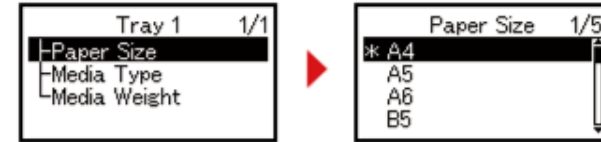

- 12 Set [Media Type].

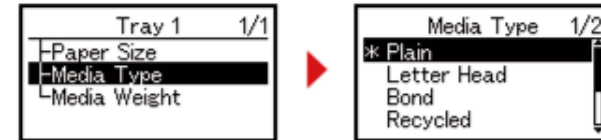

- 13 Set [Media Weight].

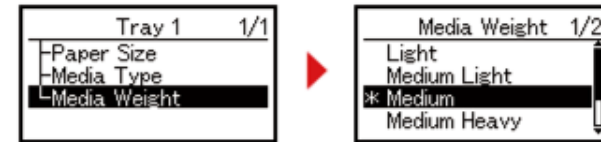

- 14 Press the ● (ONLINE) button to return to the standby screen.

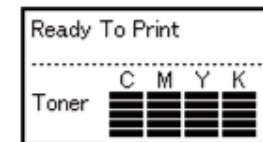

Loading Paper in the MP Tray



- Do not press down the paper or hold the paper to pull while printing on the paper fed from the MP tray. To stop printing, open the output tray.
For instructions on how to remove paper, see "[If Paper Jams Occur](#)".
- If you open and close the MP tray vigorously, the paper feed roller of MP tray may fall and get in the way of loading paper. If the paper feed roller of MP tray has fallen, raise the paper feed roller of MP tray before loading paper.

1 Open the MP tray forward by inserting your finger into the front recess.



2 Pull out the paper support by holding the center part of it.



3 Open the sub support.



4 Adjust the manual feeding paper guide to the width of paper to be loaded.



5 Make sure that the paper feed roller stays in the proper position.
If the paper feed roller has fallen, push it upward and fix it.

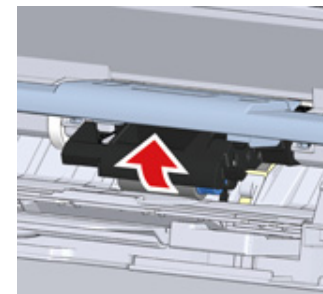



6 Insert the paper with the print side up until its edge touches the paper feed entrance.



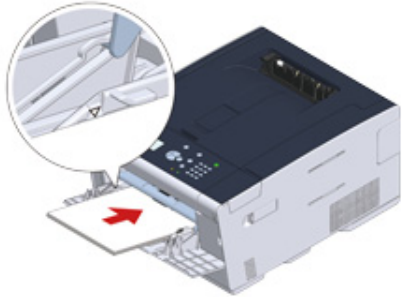

Do not load paper above the "▽" mark.



When a printer is in the power saving mode, press the  (Power Save) button to restore from the mode.

7 Press the ▲ or ▼ button on the operator panel to select [Setting] and press the  (ENTER) button.

8 Select [Paper Setup], and then press the  (ENTER) button.

9 Select the MP tray, and then press the  (ENTER) button.

10 Set [Paper Size].

11 Set [Media Type].

12 Set [Media Weight].

13 Press the  (ONLINE) button to return to the standby screen.



- Do not load paper in different sizes, types, or weights.
- When adding sheets of paper, remove paper loaded in the MP tray, bundle the whole batch of sheets, and align edges of sheets to load them.
- Do not insert objects other than paper in the MP tray.

Paper storage

Store paper under the following conditions to maintain quality.

- Inside a cabinet or other dry and dark place
- On a flat surface
- Temperature: 20°C
- Humidity: 50% RH (relative humidity)

Do not store paper in the places as shown below:

- Directly on the floor
- Where paper is exposed to direct sunlight
- Near the inside of an exterior wall
- On an uneven surface
- Where static electricity may be generated
- Where temperature excessively rises high and temperature rapidly changes
- Near this machine, an air conditioner, a heater, or duct



- Do not unwrap paper until just before you use.
- Do not leave paper unwrapped for a long period. Doing so may result in printing problems.
- Depending on the print media, environment, storage conditions the print quality may deteriorate or printout may get curled.

4

Print

Printing from a Computer (Windows)

Printing from a Computer (Mac OS X)

Cancelling a Print Job

About Screens and Functions of Each Printer Driver

"WordPad" for Windows and "TextEdit" for Mac OS X are used as examples. The screens and steps may vary depending on the application.

Printing from a Computer (Windows)

- [For Windows PCL Printer Driver](#)
- [For Windows PS Printer Driver](#)

For Windows PCL Printer Driver

- 1 Open the file to print.
- 2 Select [Print] from the [File] menu.
- 3 Select the printer driver.
- 4 Click [Preferences].

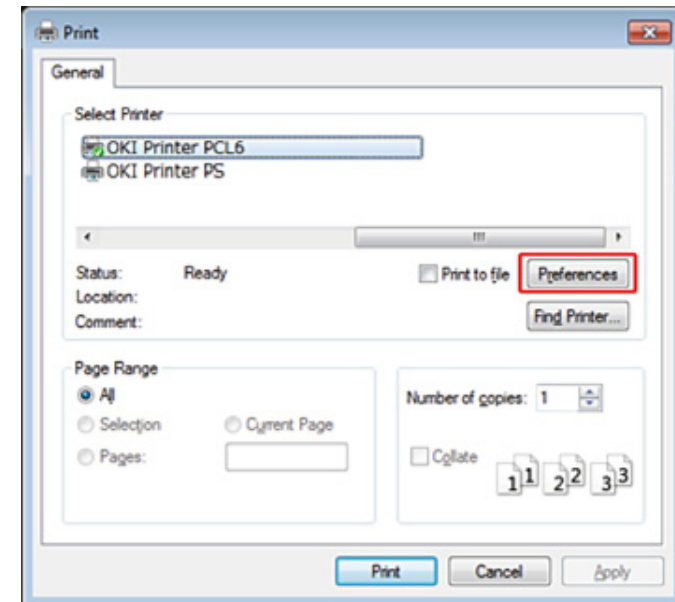

- 5 Change the settings in each tab to suit your needs.

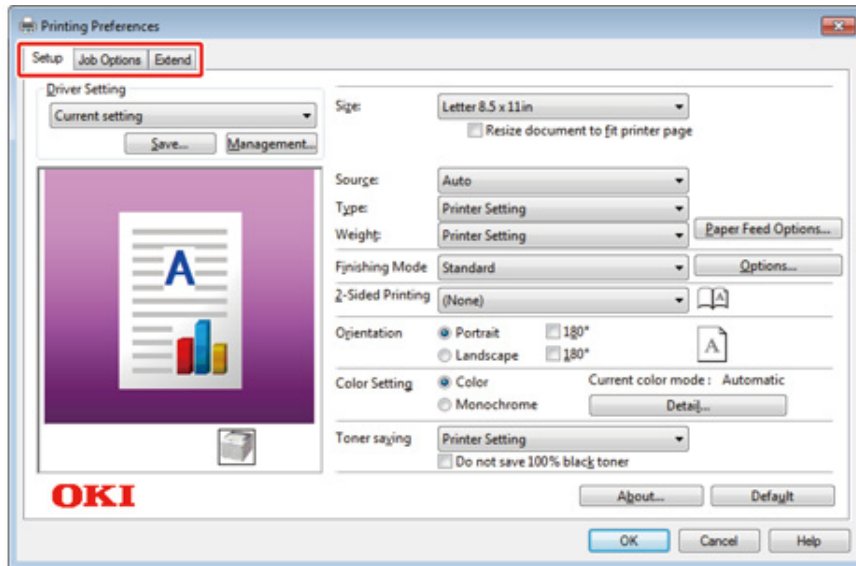

- 6 Click [OK].
7 Click [Print] on the [Print] Screen.

For Windows PS Printer Driver

- 1 Open the file to print.
- 2 Select [Print] from the [File] menu.
- 3 Select the PS printer driver.
- 4 Click [Preferences].

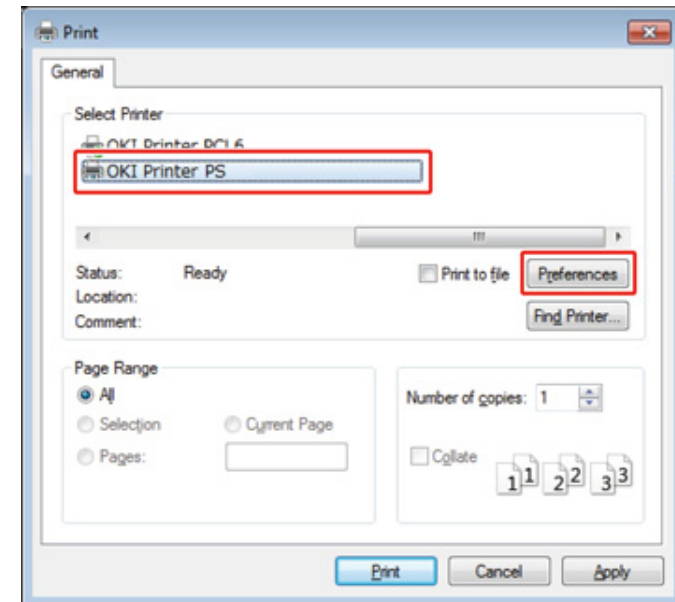

5 Change the settings in each tab to suit your needs.

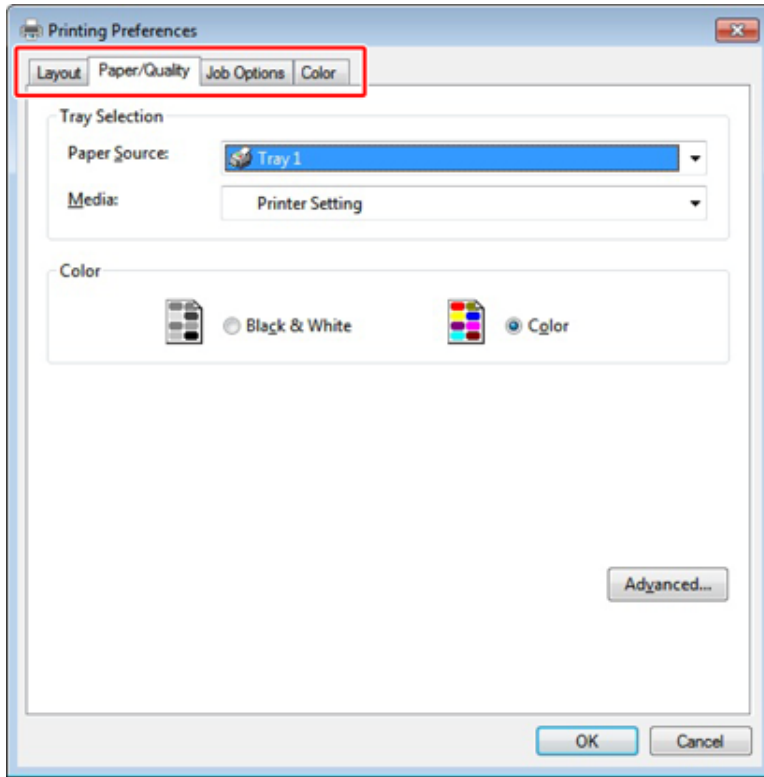

6 Click [OK].

7 Click [Print] on the [Print] screen.

Printing from a Computer (Mac OS X)

You can set a paper size, paper tray, and paper weight, and paper type with the printer driver.

- 1 Open the file to print.
- 2 Select [Print] from the [File] menu.

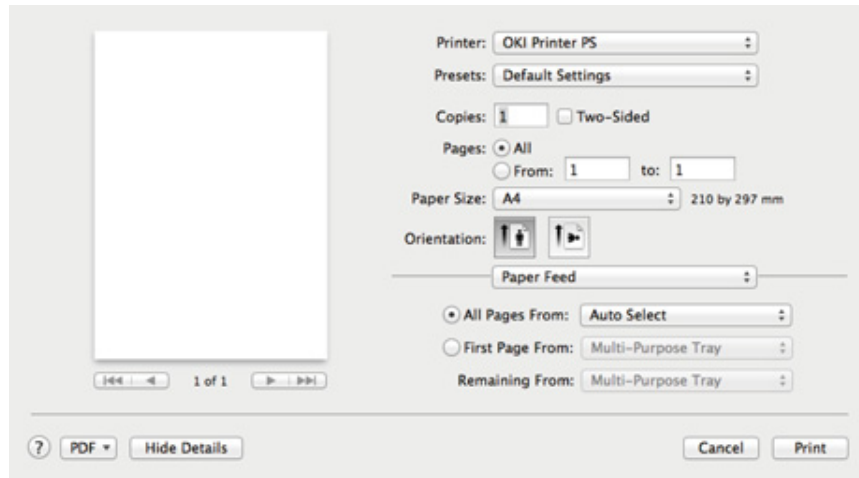

- 3 Select the machine from [Printer].
- 4 Select the paper size from [Paper Size].
- 5 Change the settings on each panel to suit your needs.



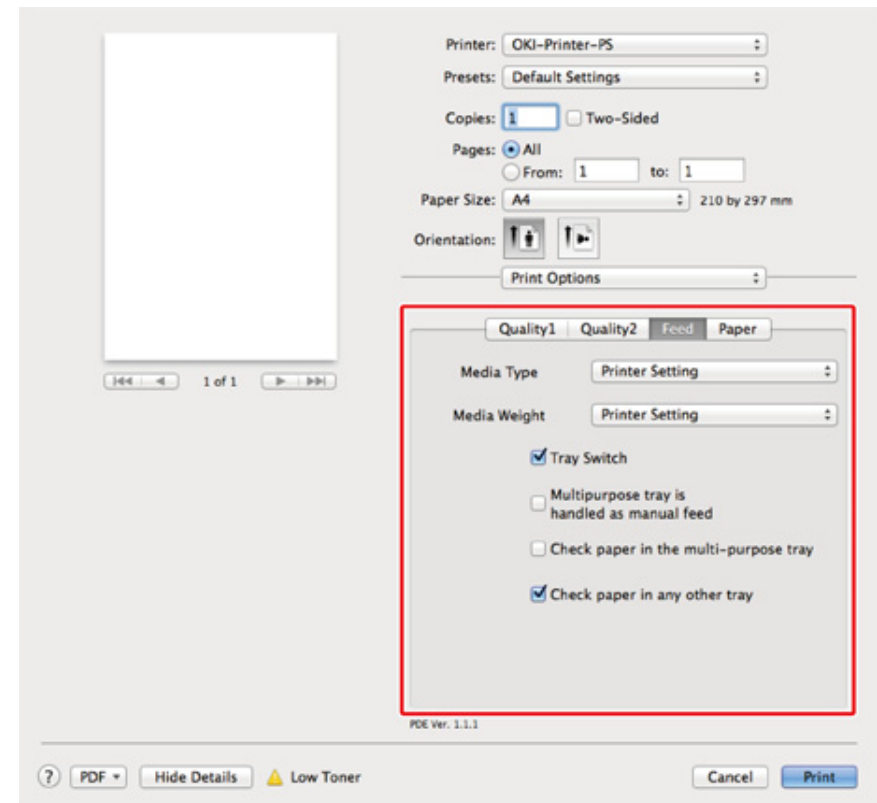

If setting details are not displayed in the print dialog box for Mac OS X 10.8.5 to 10.11, click [Show Details] at the bottom of the dialog box.





- 6 Click [Print].

Cancelling a Print Job

To cancel data currently being printed or ready to print, press the  (CANCEL) button on the operator panel.

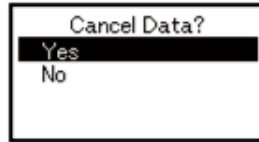
Press the  (CANCEL) button to display the following screen.



To cancel printing, select "Yes", then press the  (ENTER) button.

To continue printing, select "No", and then press the  (ENTER) button.

If no operation is made for three minutes, the screen disappears and printing resumes.

About Screens and Functions of Each Printer Driver

This section describes screens and functions of the printer drivers.

- [Windows PCL Printer Driver](#)
- [Windows PS Printer Driver](#)
- [Mac OS X PS Printer Driver](#)

Windows PCL Printer Driver

• [Setup] Tab

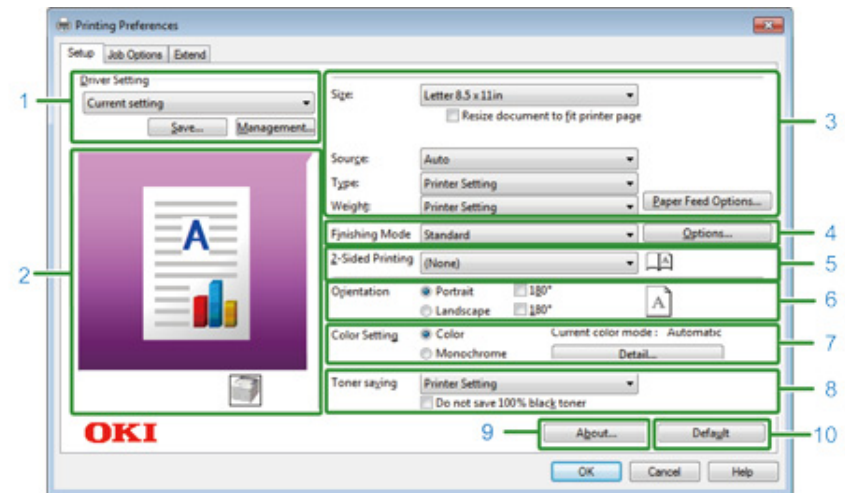

	Item	Description
1	Driver Setting	Saves your settings.
2	Image layout	Displays a sample image for the set layout.
3	Media	Specifies the paper size, type, weight, paper feed method, or other settings.
4	Finishing Mode	Specifies the multi-page printing, booklet printing, poster printing, or other settings.
5	2-Sided Printing (Duplex)	Specifies this setting when you want to perform duplex printing.
6	Orientation	Specifies the printing direction.
7	Color Setting	Switches between color printing and monochrome printing.
8	Toner saving	Decreases the print density to save toner.
9	About	Displays the version of the printer driver.
10	Default	Resets the settings on the tab to their default settings.

• [Job Options] Tab

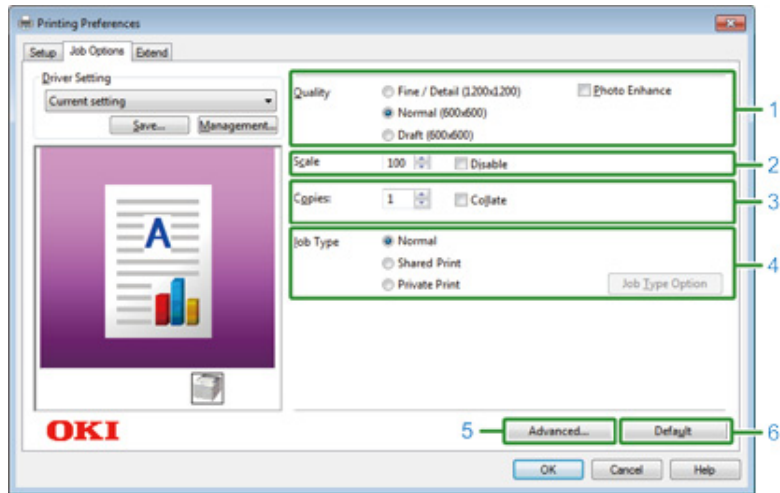

	Item	Description
1	Quality	Specifies the resolution for printing.
2	Scale	Specifies the enlargement/reduction rate for printing.
3	Copies	Specifies the number of copies to print.
4	Job Type	Specifies the print type.
5	Advanced	Sets other printing settings.
6	Default	Resets each setting value in the tab to its default setting value.

• [Extend] Tab

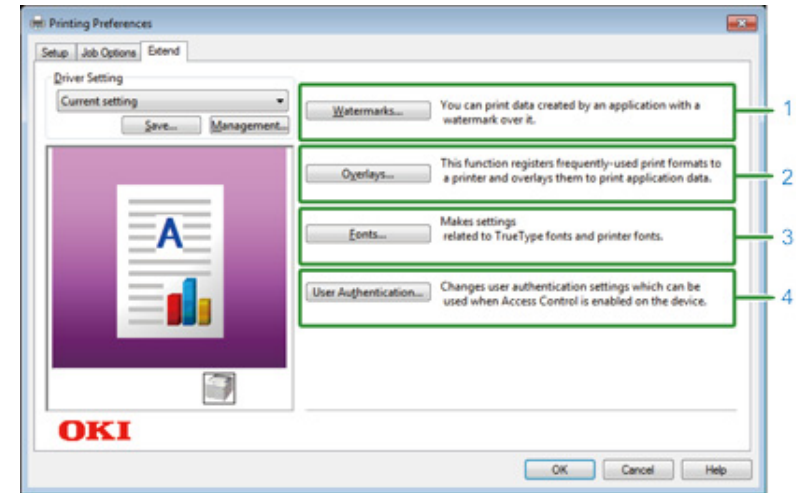

	Item	Description
1	Watermarks	Specifies when you want to use stamp print.
2	Overlays	Sets when printing print formats which are registered to the printer beforehand as overlays.
3	Fonts	Specifies TrueType fonts and printer fonts.
4	User Authentication	Specifies the user authentication.

Windows PS Printer Driver

• [Layout] Tab

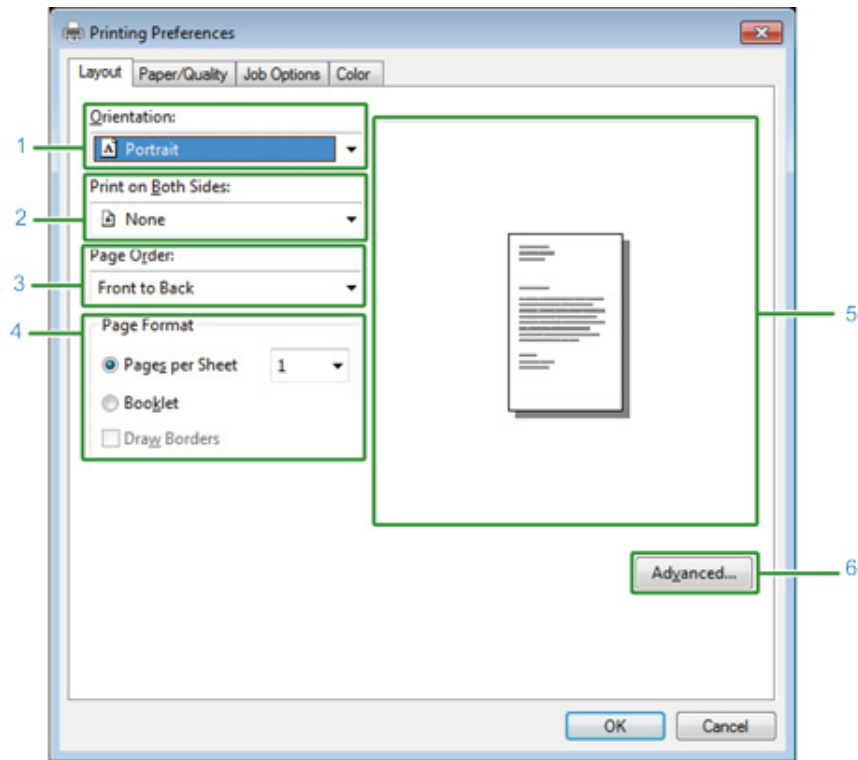

	Item	Description
1	Orientation	Specifies the printing direction.
2	Print on Both Sides	Specifies this setting when you want to perform duplex printing.
3	Page Order	Specifies a page order to print.
4	Page Format	Specifies the number of pages that is printed on a sheet of paper and booklet printing.
5	Image layout	Displays a sample image for the set layout.
6	Advanced	Allows you to set detailed settings for print quality and a paper size.

• [Paper/Quality] Tab

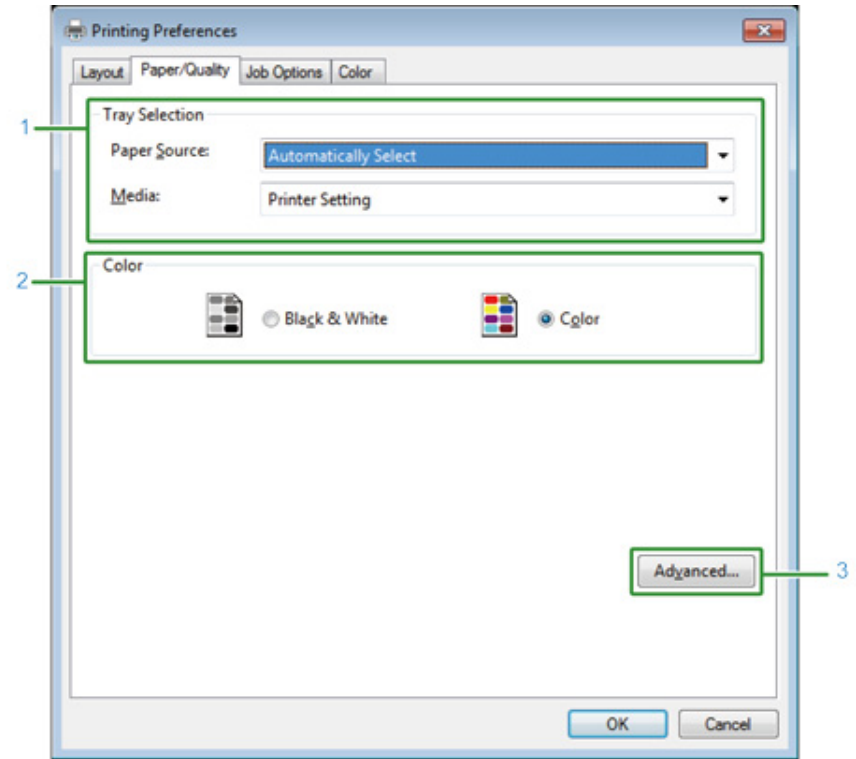

	Item	Description
1	Tray Selection	Changes the paper feed tray.
2	Color	Selects Color or Black & White.
3	Advanced	Allows you to set detailed settings for print quality and a paper size.

• [Job Options] Tab

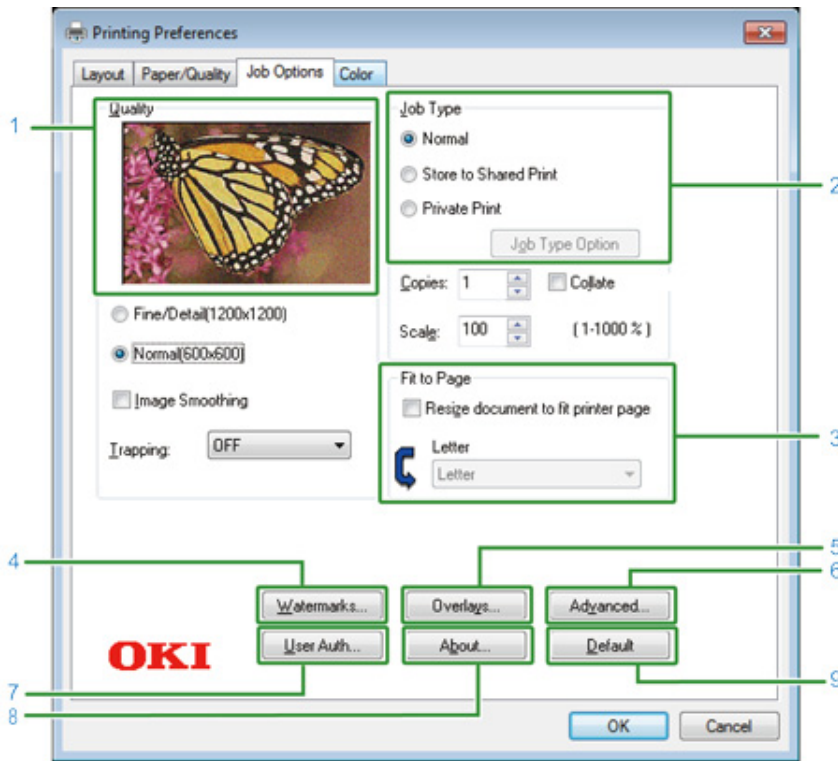

Item	Description	
1	Quality	Specifies the resolution for printing. If you set [Toner Saving], the print density decreases to save toner.
2	Job Type	Specifies the job type and the number of copies to print. [Job Type Option] can be used if [Store to Shared Print] or [Private Print] is selected. If you select the [Collate] check box, multiple documents are printed in units of copies.
3	Fit to Page	If you select the [Resize document to fit printer page] check box, a document is printed on paper of a different size.
4	Watermarks	Specifies when you want to use stamp print.
5	Overlays	Sets when printing print formats which are registered to the printer beforehand as overlays.
6	Advanced	Sets other print options.
7	User Auth	Specifies the user authentication.
8	About	Displays the version of the printer driver.

Item	Description	
9	Default	Resets the settings on the tab to their default settings.

• [Color] Tab

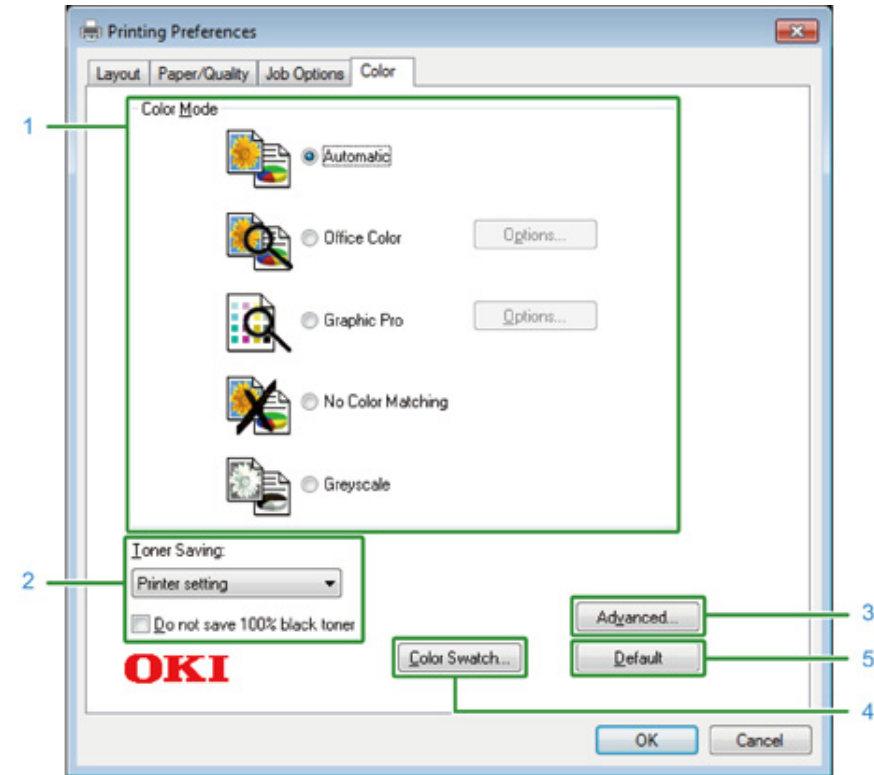

Item	Description	
1	Color Mode	Specifies the color adjustment for color printing.
2	Toner Saving	Saves toner when printing.
3	Advanced	Sets some other printing settings.
4	Color Swatch	Starts Color Swatch Utility.
5	Default	Resets the settings on the tab to their default settings.

Mac OS X PS Printer Driver

• [Layout] Panel

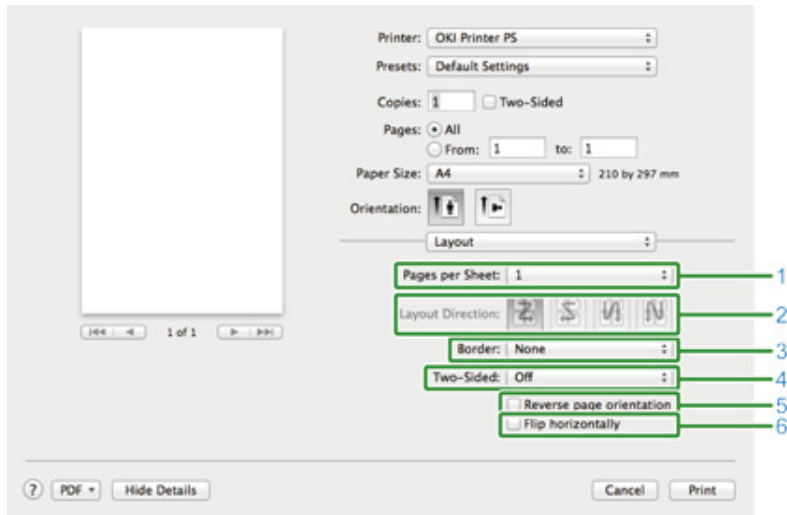

	Item	Description
1	Pages per Sheet	Selects the number of pages that is printed on a sheet of paper.
2	Layout Direction	Specifies the layout that is applied when printing multiple pages on a sheet of paper.
3	Border	Specifies a type of a boundary.
4	Two-Sided	Specifies when performing duplex printing.
5	Reverse page orientation	Reverses the direction of a page to print by selecting this check box.
6	Flip horizontally	Flips left and right to print by selecting this check box.

• [Color Matching] Panel

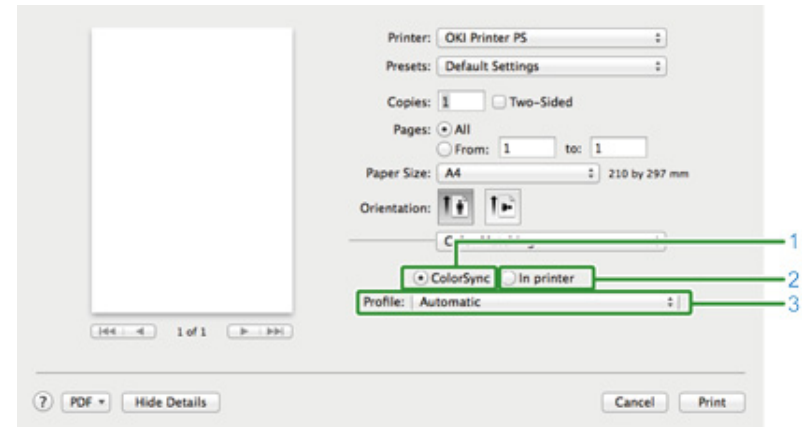

	Item	Description
1	ColorSync	Specifies the ColorSync function.
2	In printer	Performs color matching with this machine.
3	Profile	Specifies a profile.

• [Paper Handling] Panel

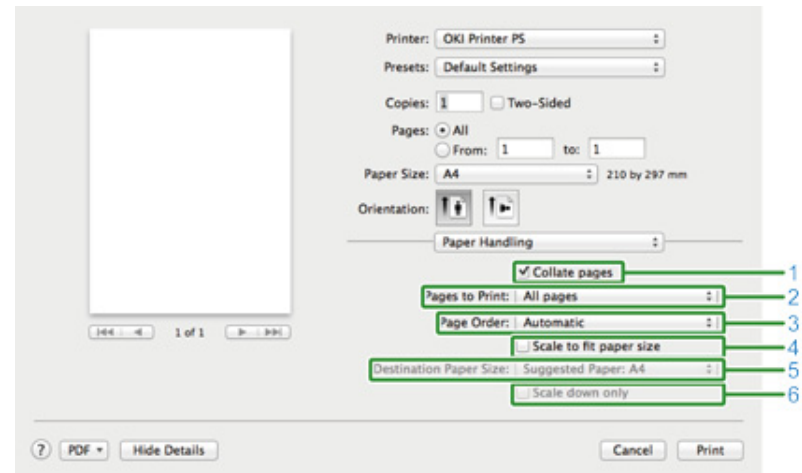

	Item	Description
1	Collate pages	Prints in units of copies by selecting this check box.

	Item	Description
2	Pages to Print	Specifies pages to print.
3	Page Order	Specifies a page order to print.
4	Scale to fit paper size	Prints to fit a paper size. Enlarges or reduces to fit the output paper size. Enlarges or reduces a document to fit the output paper size by selecting this check box.
5	Destination Paper Size	Selects the output paper size when the [Scale to fit paper size] check box is selected.
6	Scale down only	Only reduces a document to fit the output paper size by selecting this check box.

• [Paper Feed] Panel

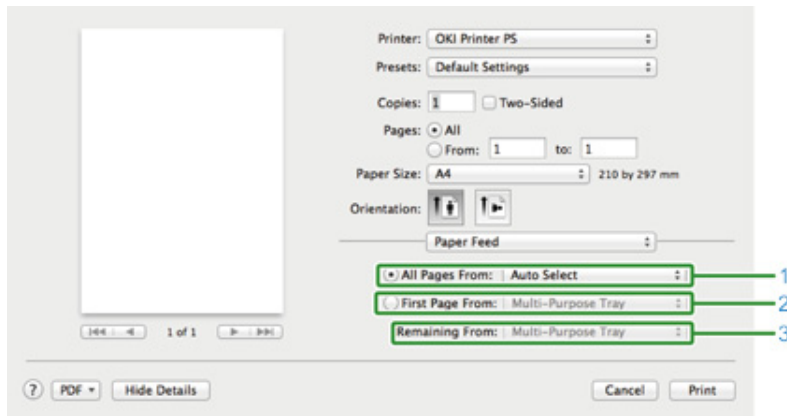

	Item	Description
1	All Pages From	Specifies the paper feed tray. If you specify [Auto Select], a tray is automatically selected.
2	First Page From	Select this setting to print only the first page from the specified tray.
3	Remaining From	Select this setting to print the remaining pages from the specified tray.

• [Cover Page] Panel

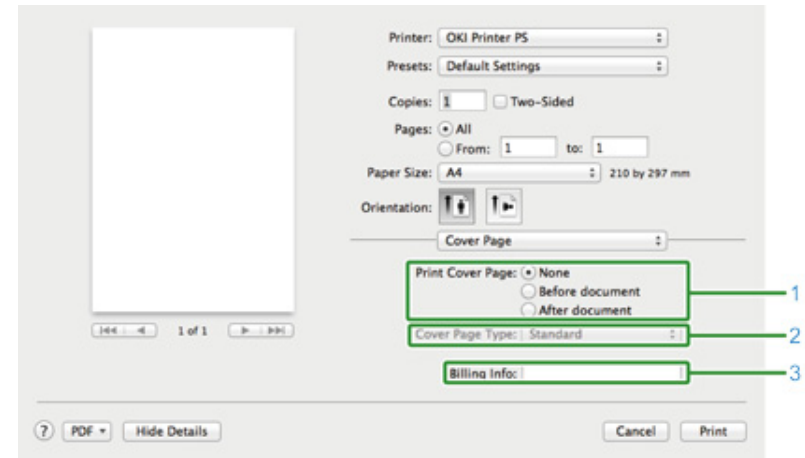

	Item	Description
1	Print Cover Page	Specifies the cover printing.
2	Cover Page Type	Specifies a string when printing the cover.
3	Billing Info	This function is not available.

• [Color] Panel

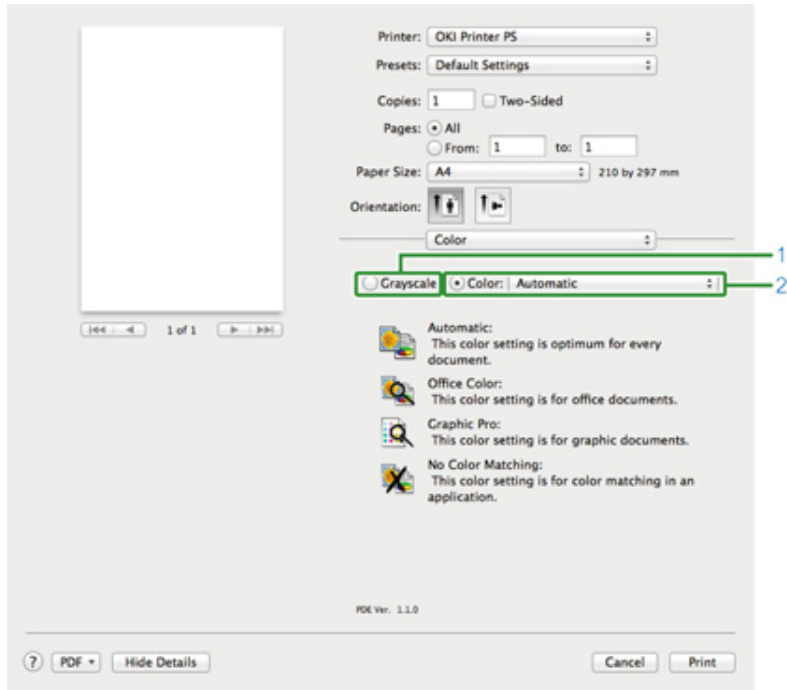

	Item	Description
1	Grayscale	Specifies to use monochrome printing.
2	Color	Specifies alignment to color mode when printing in color.

• [Print Options] Panel

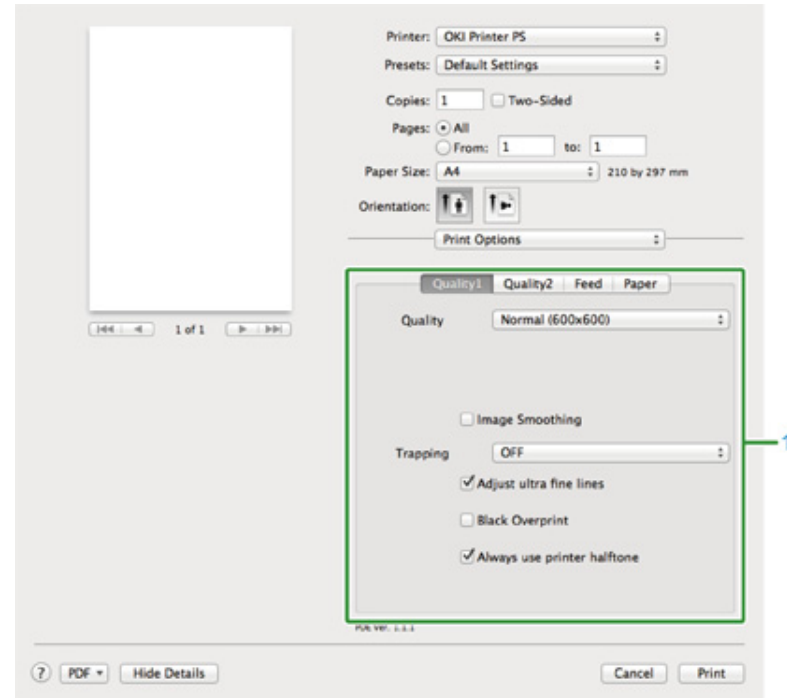

	Item	Description
1	Quality1, Quality2, Feed, Paper	Specifies the print quality, toner saving, paper type, etc.

• [User Authentication] Panel

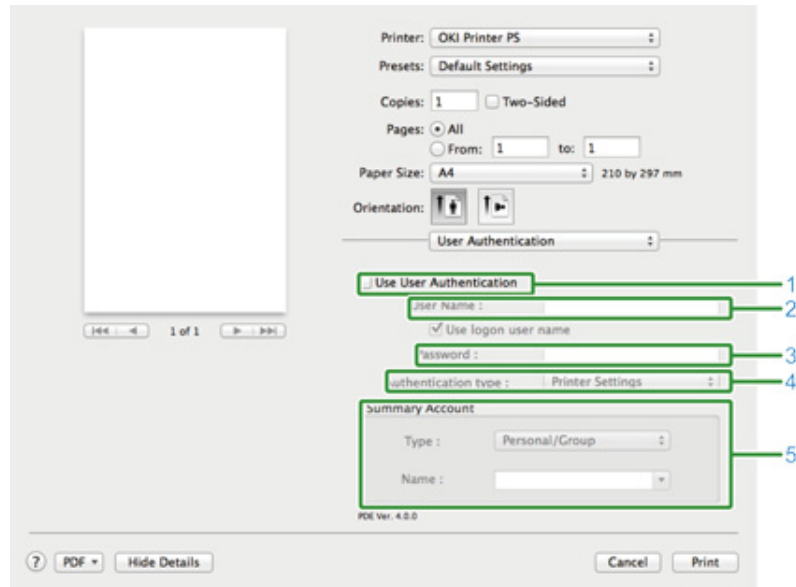

	Item	Description
1	Use User Authentication	Select this check box if you set user authentication when printing.
2	User Name	The user name for user authentication.
3	Password	The password for user authentication.
4	Authentication type	Specify an authentication type to be used.
5	Summary Account	Specify an account name and type.



[Authentication type], [Summary Account] can be enabled from the apple menu, select [System Preferences] > [Printers & Scanners], select the device and enable the device in the [Options] tab of [Options & Supplies].

• [Secure Print] Panel

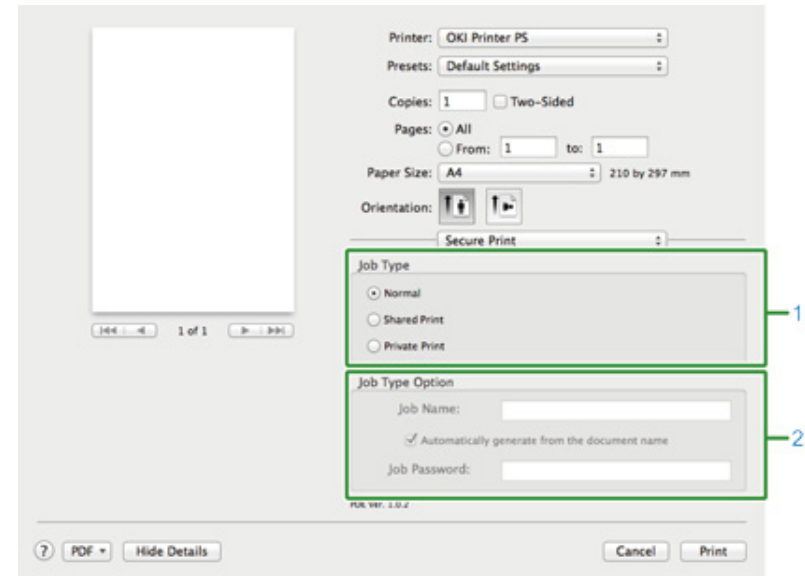

	Item	Description
1	Job Type	Specifies the job type. [Job Type Option] can be used if [Shared Print] or [Private Print] is selected.
2	Job Type Option	Specify a job name to be displayed on the operator panel and password required when printing.

• [Supply Levels] Panel

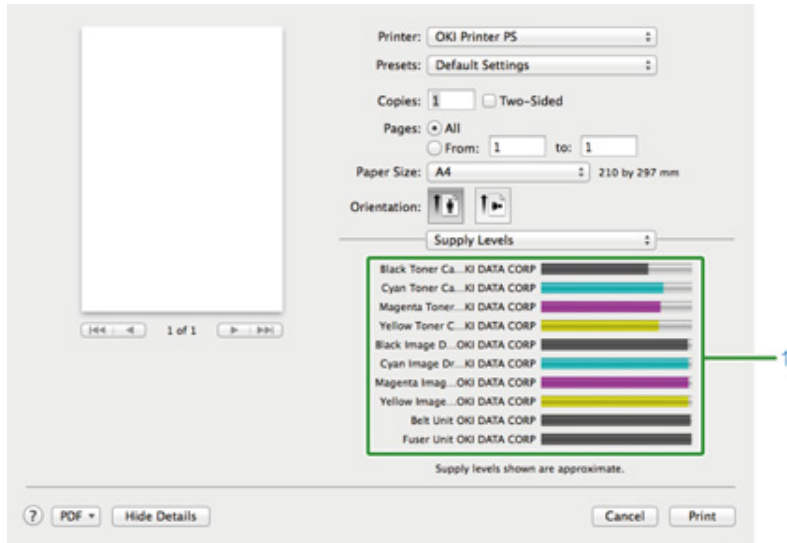

	Item	Description
1	Consumables	Displays the remaining amount of consumables.



The [Supply Levels] panel may not appear depending on the environment such as how to connect to the device.

5

Maintenance

Replacing Consumables

Cleaning Each Part of the Machine

This category describes consumable replacements and cleaning to ensure a comfortable use of the machine for a longer life.





Replacing Consumables







This section describes how to replace consumables.





- [Cautions When Replacing Consumables](#)
- [Replacing the Toner Cartridges](#)
- [Replacing the Image Drum](#)
- [Replacing the Image Drum and Toner Cartridge at the Same Time](#)

Cautions When Replacing Consumables

Observe the following cautions when replacing.

 WARNING	
	Do not throw the toner or toner cartridge into a fire. The toner will scatter, resulting in burns.
	Do not store a toner cartridge in a location where it is exposed to open flames. The toner may ignite, resulting in fire or burns.
	Do not vacuum spilled toner with an electric vacuum cleaner. Vacuuming spilled toner with an electric vacuum cleaner may result in ignition due to sparks from electric contacts or other reasons. If toner spills on the floor or other places, wipe the toner with a damp rag or other cloth.

 CAUTION	
	Some parts inside the machine become very hot. Do not touch the locations around a "CAUTION HOT" label. Burns may result.
	Keep toner cartridges out of the reach of children. If a child accidentally swallows toner, immediately seek medical advice.
	If you inhale toner, gargle with a large amount of water, and move to a place with fresh air. Seek medical advice if necessary.
	If toner lands on your hands or other areas of skin, wash thoroughly with soap and water.
	If toner gets into your eyes, immediately rinse with a large amount of water. Seek medical advice if necessary.

 CAUTION	
	If you swallow toner, spit it out. Seek medical advice if necessary.
	When handling a paper jam or replacing toner cartridges, use care not to let your clothes or hands get dirty with toner. If toner lands on your clothes, wash with cold water. If toner gets hot by washing with hot water or other methods, the toner will stain the fabric and become impossible to remove.
	Do not disassemble the image drum or toner cartridge. You may inhale the scattered toner, or the toner may land on your hands or clothes, making them dirty.
	Store used toner cartridges by putting them into a bag while using care not to scatter the toner.



- Use OKI genuine consumables to ensure optimum performance of the products.
- Charges for services for problems caused by the use of consumables other than OKI genuine consumables are incurred, regardless of the warranty or in the maintenance contract. (Although the use of non-genuine consumables does not always result in problems, use extra care when using them.)

Replacing the Toner Cartridges

When the "[COLOR] Toner Low" message ("[COLOR]" indicates C (cyan), M (magenta), Y (yellow) or K (black)) which appears on the display screen, prepare a replacement toner cartridge.

When the "[COLOR] Toner empty. Replace with new Toner Cartridge." appears and printing stops, replace the toner cartridge.



Even if the cyan (blue), magenta (red) or yellow toner cartridges run out, you can print in black and white by selecting [Monochrome] or [Grayscale]. However, please replace the toner cartridge quickly after it runs out, as not doing so may cause the image drum to be damaged.



- Have a new toner cartridge ready, as the print quality declines after more than one year following breaking the seal.
- If you replace the toner cartridge/image drum while it is being used, the toner consumption will not be counted normally.
- By opening and closing the output tray after the message "Install Toner" is displayed, you are able to print. Please replace the toner cartridge as failure to do so may damage the image drum.
- Toner powder may spill if you remove a toner cartridge before the toner runs out.

- 1 Prepare new toner cartridges.
- 2 Press the button (A) and open the output tray (a) completely.

 **CAUTION**

Burns may result.



The fuser unit is extremely hot. Do not touch it.

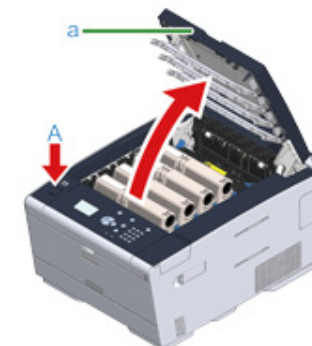

- 3 Identify an empty toner cartridge by its label color.
- 4 Pinch the tip of blue lever (b) of the toner cartridge and turn it toward you until the tip aligns on the lug of the cartridge.

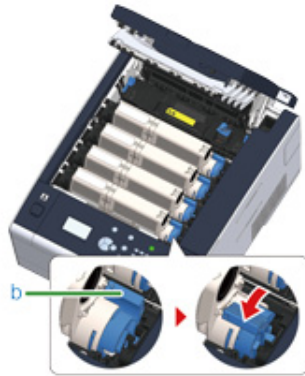

- 5 Lift the toner cartridge (c) from right side, and remove it from the machine.

⚠ WARNING

Burns may result.



Never throw used toner cartridges into a fire. They may explode, and the toner inside may fly off and cause burns.



While removing consumables, be careful not to hit them to the LED head.

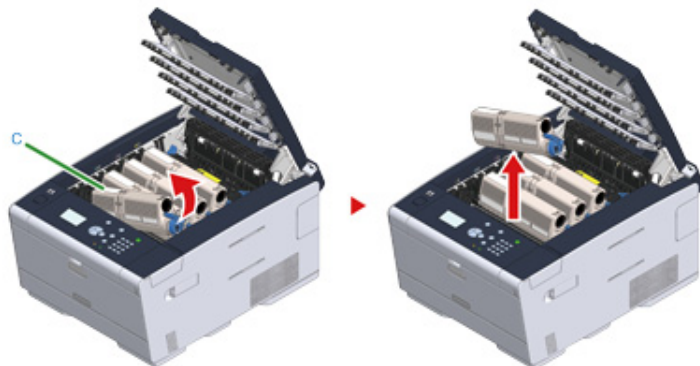

- 6 Unpack a new toner cartridge.

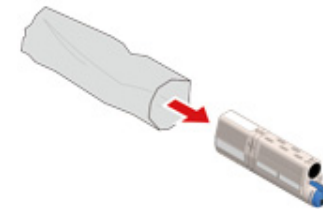

- 7 Shake the cartridge several times vertically and horizontally.

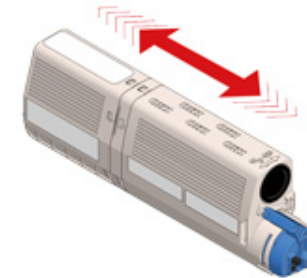

- 8 Remove the tape (d) from the toner cartridge.

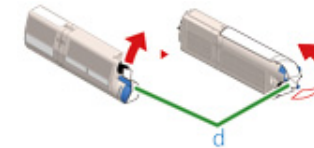

- 9 Insert a new toner cartridge (c) by aligning its left side indentation (e) with the protrusion (f) on the image drum so the toner cartridge and image drum color labels align. Then insert the right side gently into place.



Do not insert a toner cartridge without removing the tape.

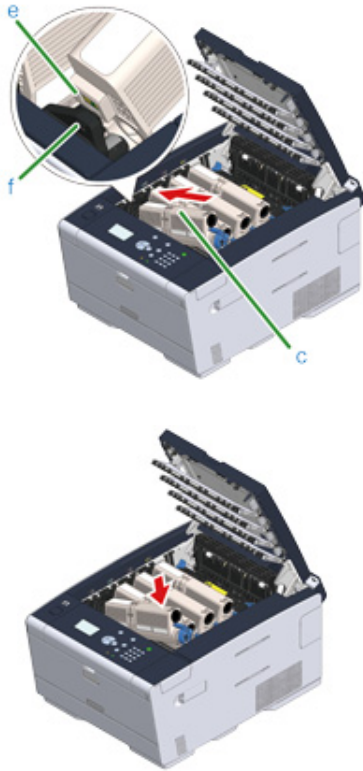

- 10** Hold the cartridge, pinch the tip of blue lever (b) of the toner cartridge, and turn forward until the tip aligns on the lug of the cartridge.

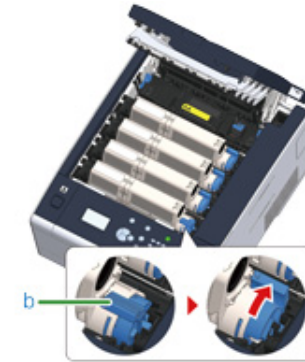

- If you close the output tray without turning the blue lever when installing the toner cartridge into the image drum, it may cause a malfunction. Be sure to turn the blue lever until its top aligns on the lug in the back of the toner cartridge.
- If the toner cartridge is not securely attached, printing quality may deteriorate.

- 11** Wipe the lens of the LED head with a soft tissue paper lightly.

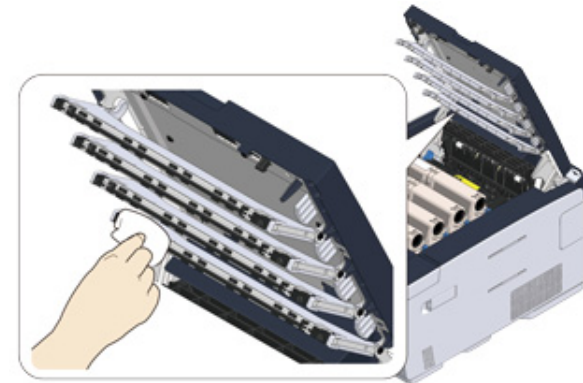

Do not use solvents, such as methyl alcohol or thinners. They damage the LED head.

- 12** Close the output tray (a) slowly and push the center of the output tray for confirmation.

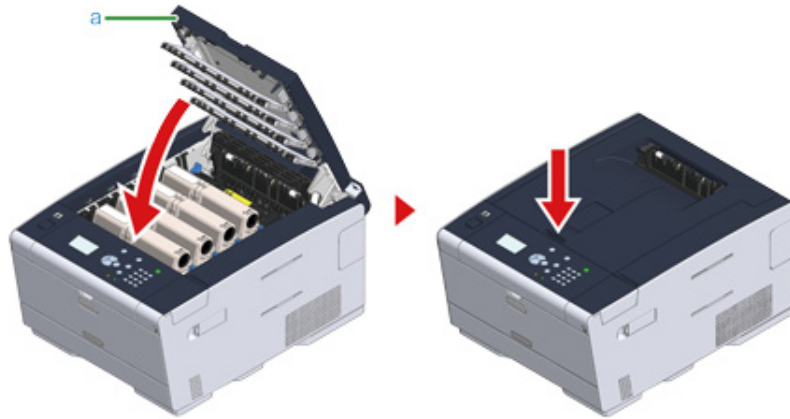

- 13** Please recycle toner cartridges.



If you have to dispose of used toner cartridges, put them into polyethylene bags or other container, and be sure to follow the regulations or instructions of your local government.

Replacing the Image Drum

When the "[COLOR] Image Drum Near Life" message appears on the display screen, prepare a replacement image drum. If you continue printing, the message "Install New Image Drum/ Image Drum Life" will be displayed and printing will stop.

When the "[COLOR] Image Drum Life" message is displayed and printing stops, replace the image drum.

When using A4 paper (simplex printing), the estimated replacement cycle of an image drum is approximately 30,000 pages. This estimation assumes the standard use condition (three pages are printed at a time). Printing one page at a time reduces the drum lifetime approximately by half.

The actual number of printed pages may be less than half the above estimation depending on the printing conditions.



- The actual number of pages you can print with the image drum depends on how you use the machine. It may be less than half the above estimation depending on the printing conditions.
- Printing quality may deteriorate after 1 year following the unpacking of the toner cartridge. Replace the toner cartridge with a new one.
- Although opening and closing the output tray may extend the life of an image drum for a while, it is recommended to replace it soon after the "Image Drum Life" message is displayed.
- If you press the ▲ or ▼ button on the operator panel to select [Setting] > [Admin Setup] > [Manage Unit] > [System Setup] and set [Status in Near Life] to [Disable], the "[COLOR] Image Drum Near Life" message will not be displayed.
- Use OKI genuine consumables to ensure optimum performance of the products.
- Charges for services for problems caused by the use of consumables other than OKI genuine consumables are incurred, regardless of the warranty or in the maintenance contract. (Although use of non-genuine consumables does not always result in problems, use extra care when using them.)

This section describes how to replace the image drum when you want to continue using the toner cartridge.



- If you use a new image drum with the toner cartridges currently in use, the remaining amount indication of the toner cartridges will not display correctly. The messages "[COLOR] Toner Low" or "Incompatible Toner/ [COLOR]" may also be displayed soon after replacement.
- Use extra care when handling the image drum (the green cylinder), because it is fragile.
- Do not expose the image drum to direct sunlight or strong light (approximately 1,500 lux or more). Even under room lighting, do not leave the image drum for 5 minutes or more.



You can set when to display the "[COLOR] Image Drum Near Life" message. Press the ▲ or ▼ button on the operator panel to select [Setting] > [Admin Setup] > [User Install] > [Drum Near Life Timing] on the operator panel to change the setting. Available values are from 500 to 3,000 (in 500 increments).

- 1 Prepare new image drum.
- 2 Press the button (A) and open the output tray (a) completely.

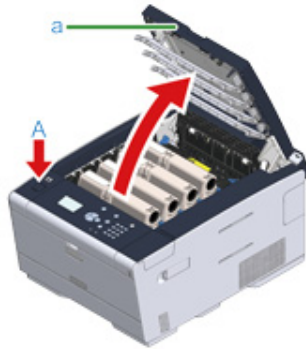

- 3 Identify the image drum that reached its lifetime by its label color.
- 4 Remove the image drum (b) from the machine and place the image drum on a flat surface.



While removing consumables, be careful not to hit them to the LED head.

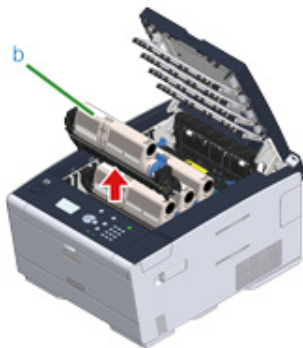

- 5 Hold the cartridge, pinch the tip of blue lever (c) of the toner cartridge, and turn it toward you until the tip aligns on the lug of the cartridge.

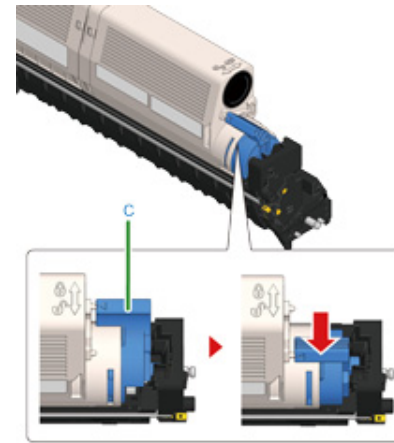

- 6 Lift the toner cartridge (d) from the right side, and remove it from the image drum.

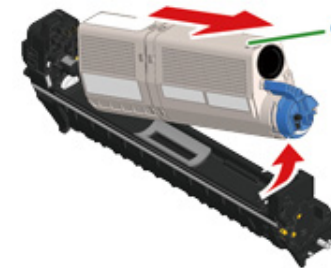

- 7 Unpack a new image drum and place it on a flat surface.

- 8 Remove the desiccant pack.

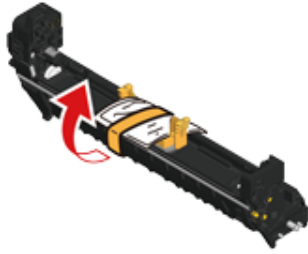

- 9 Remove the toner cover.

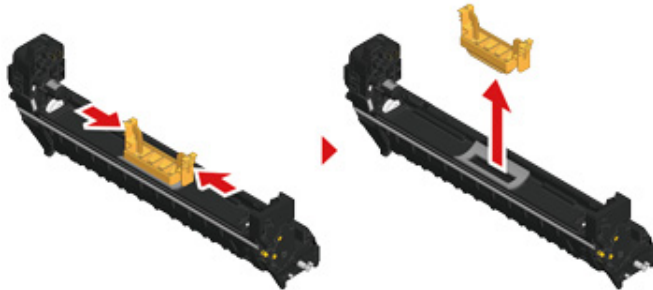

- 10 Insert the toner cartridge (d) removed in step 6 by aligning its left side indentation (e) with the protrusion (h) on the image drum so that the toner cartridge and image drum color label align. Then insert the right side gently into place.

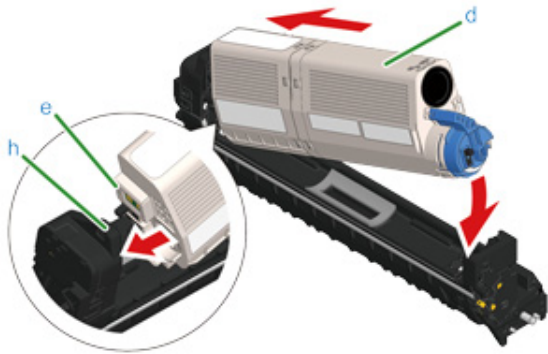

- 11 Hold the cartridge, pinch the tip of blue lever (g) of the toner cartridge, and turn forward until the tip aligns on the lug of the cartridge.

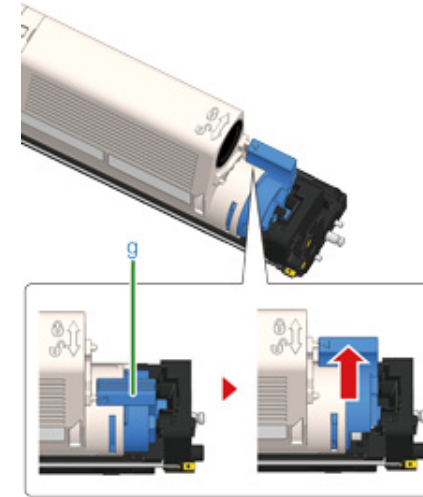

If you close the output tray without turning the blue lever when installing the toner cartridge into the image drum, it may cause a malfunction. Be sure to turn the blue lever until its top aligns on the lug in the back of the toner cartridge.

- 12 Check the label color of the new image drum and place the drum into the machine.

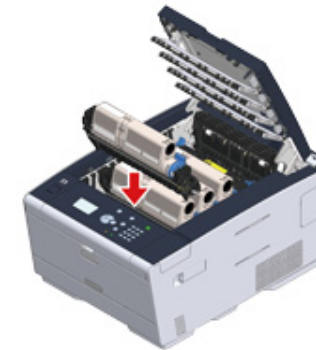

- 13** Close the output tray (a) slowly and push the center of the output tray for confirmation.

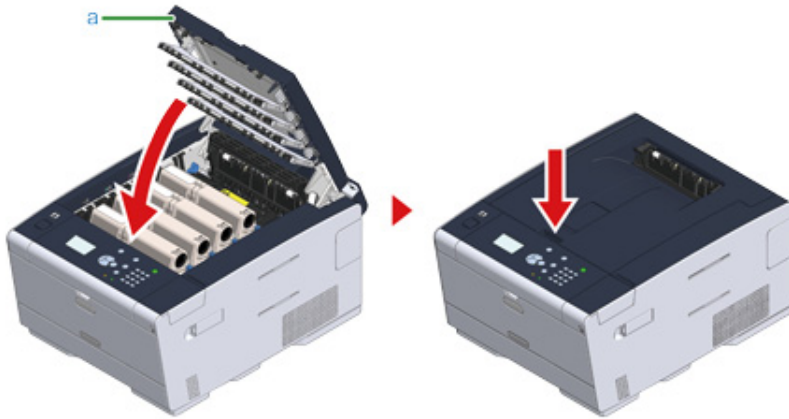

- 14** Please recycle image drums.



If you must dispose of an image drum, put it in a plastic bag or similar container and dispose of it in accordance with your municipality's ordinances or guidelines.

Replacing the Image Drum and Toner Cartridge at the Same Time

This section describes how to replace the image drum and toner cartridge with new ones at the same time.



- Use extra care when handling the image drum (the green cylinder), because it is fragile.
- Do not expose the image drum to direct sunlight or strong light (approximately 1,500 lux or more). Do not leave the image drum for 5 minutes or more even under room light.

- 1 Prepare new image drum and toner cartridge.
- 2 Press the button (A) and open the output tray (a) completely.

CAUTION

Burns may result.



The fuser unit is extremely hot. Do not touch it.

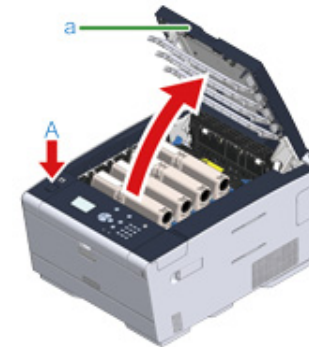

- 3 Identify an empty toner cartridge by its label color.
- 4 Remove the image drum (b) from the machine and place it on a flat surface.



While removing consumables, be careful not to hit them to the LED head.

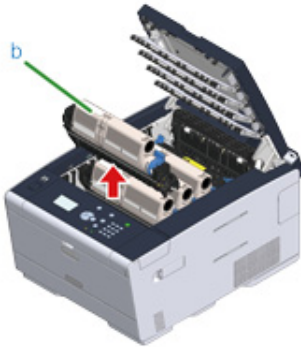

WARNING	Burns may result.	
<p>Never throw a used image drum or toner cartridge into a fire. They may explode, and the toner inside may fly off and cause burns.</p>		

- 5 Unpack a new image drum and place it on the flat surface.
- 6 Remove the desiccant pack.

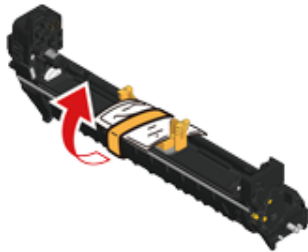

- 7 Remove the toner cover.

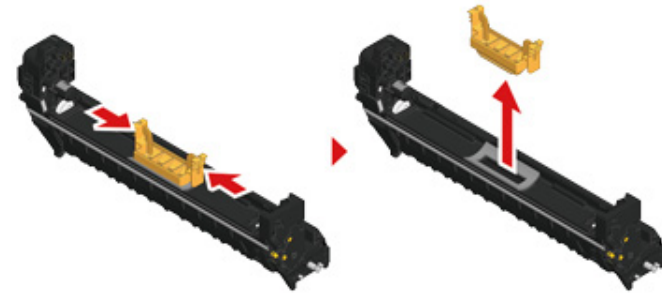

- 8 Unpack a new toner cartridge.

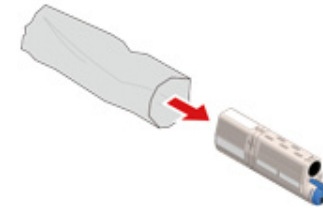

- 9 Shake the cartridge several times vertically and horizontally.

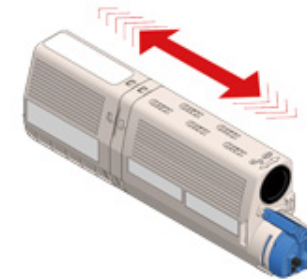

- 10 Remove the tape (c) from the toner cartridge.

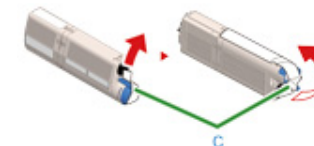

- 11** Insert a new toner cartridge (d) by aligning its left side indentation (e) with the protrusion (f) on the image drum so that the toner cartridge and image drum color label align. Then insert the right side gently into place.

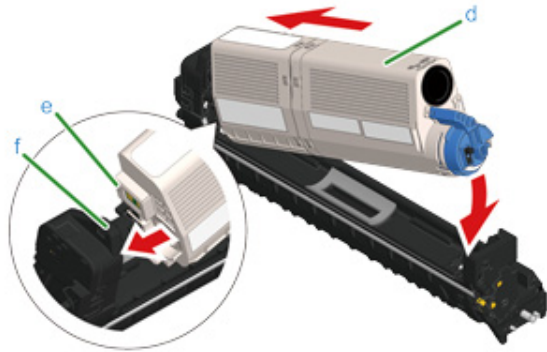

For the installation method, refer to "Replacing the Toner Cartridges".

- 12** Hold the cartridge, pinch the tip of blue lever (g) of the toner cartridge, and turn forward until the tip aligns on the lug of the cartridge.

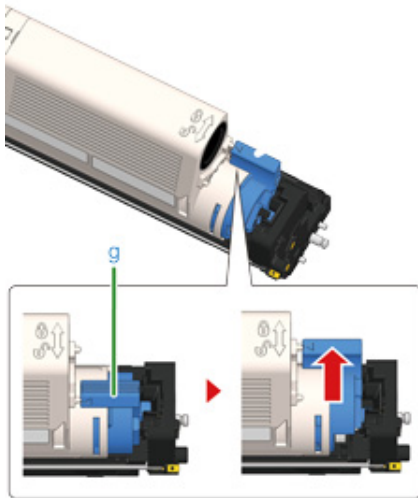

If you close the output tray without turning the blue lever when installing the toner cartridge into the image drum, it may cause a malfunction. Be sure to turn the blue lever until its top aligns on the lug in the back of the toner cartridge.

- 13** Check a label color of a new image drum and place the drum into the machine.

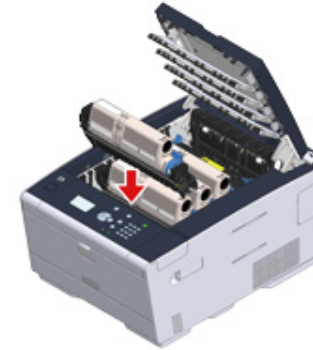

- 14** Close the output tray (a) slowly and push the center of the output tray for confirmation.

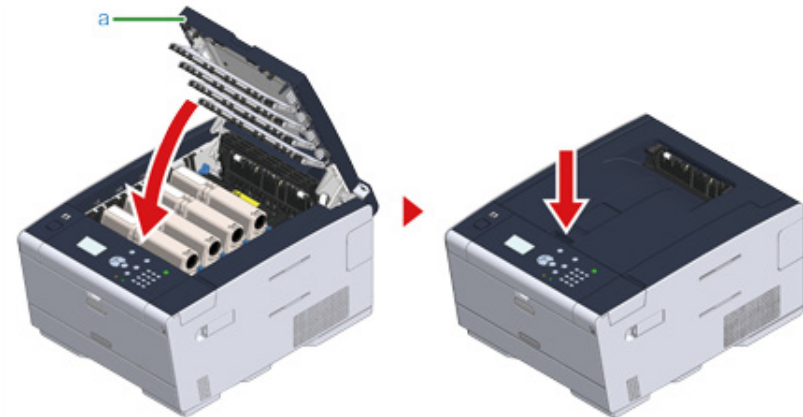

- 15** Please recycle image drums and toner cartridges.



If you must dispose of an image drum, put it in a plastic bag or similar container and dispose of it in accordance with your municipality's ordinances or guidelines.

Cleaning Each Part of the Machine

This section describes how to clean the machine and parts.

- Cleaning the Surface of the Machine (Advanced Manual)
- Cleaning the Paper Feed Rollers (Tray 1/Tray 2/Tray 3) (Advanced Manual)
- Cleaning the Paper Feed Rollers (MP Tray) (Advanced Manual)
- [Cleaning the LED Head](#)

Cleaning the LED Head

Clean the LED head if vertical white lines appear, images are faded, or the periphery of letters are smudged in the printouts.



- Do not use solvents, such as methyl alcohol or thinners, because they may damage the LED head.
- Do not expose the image drum to direct sunlight or strong light (approximately 1,500 lux or more). Even under room lighting, do not leave the image drum for 5 minutes or more.

1 Press the button (A) and open the output tray (a) completely.

 **CAUTION**

Burns may result.



The fuser unit is extremely hot. Do not touch it.

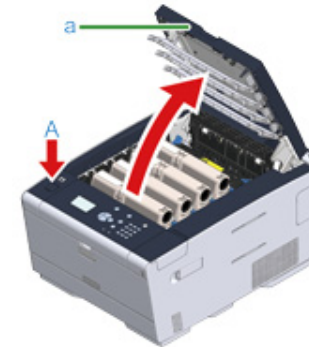

2 Wipe the four lenses of the LED heads with a soft tissue paper lightly.

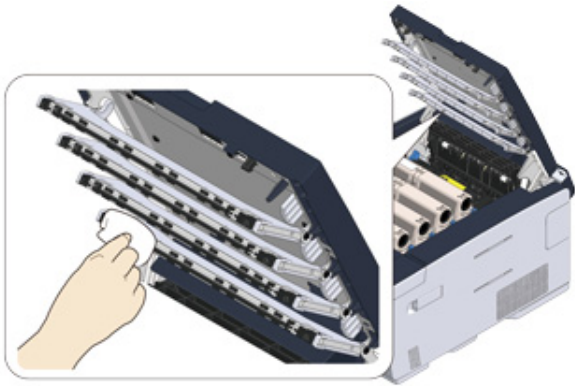

3 Close the output tray (a) slowly and push the center of the output tray for confirmation.

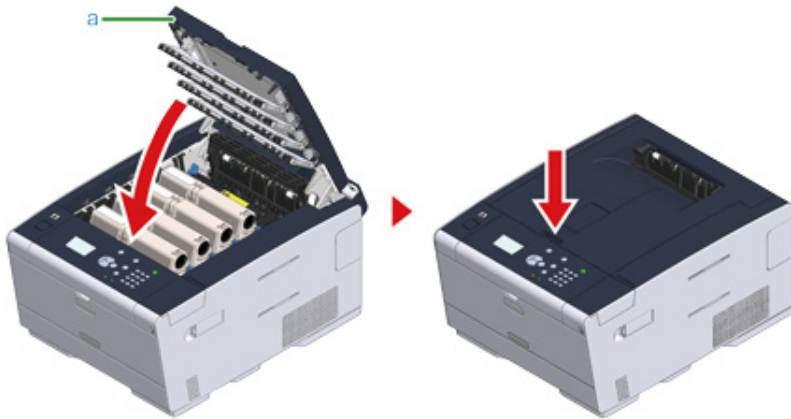

6

Troubleshooting

If Paper Jams Occur

Print Problems

If an Error Message is Displayed on the Operator Panel

If Paper Jams Occur

This section describes how to handle when a paper jam occurs. Check the error code on the operator panel and see the corresponding page.

- If the Error Code is "370", "371", "372"
- If the Error Code is "380", "381", "382", "385", "389"
- If the Error Code is "390"
- If the Error Code is "391", "392", "393"
- If the Error Code is "409"

If the Error Code is "370", "371", "372"

- 1 Press the button (A) and open the output tray (a) completely.

CAUTION

Burns may result.



The fuser unit is extremely hot. Do not touch it.

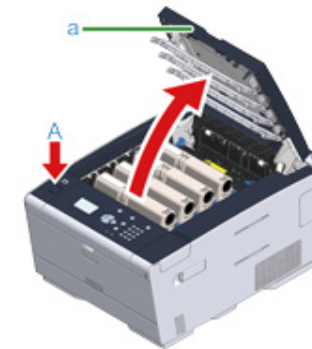

- 2 Remove the four image drums from the machine and place the image drums on a flat surface.



While removing consumables, be careful not to hit them to the LED head.



- 3 Cover the removed image drums with paper so that the image drums are not exposed to light.

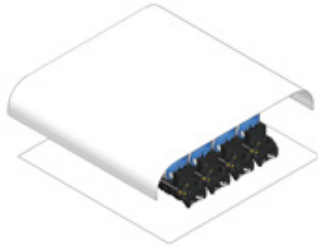

- 4 Pull out the jammed paper gently to the rear of the machine (the direction of the arrow) if an edge of jammed paper can be seen.



- 5 If paper jams in the fuser unit, press the jam release lever (b) on the fuser unit and slowly pull the jammed paper toward you.



- 6 Tilt back the lock levers on the both sides of the fuser unit toward you.

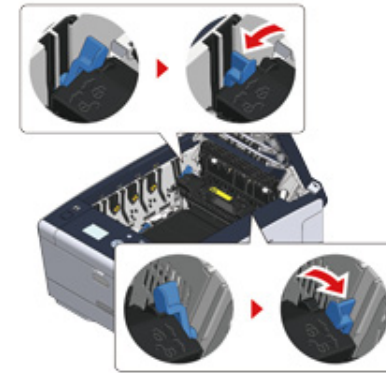

- 7 Hold the fuser unit handle and lift the fuser unit out of the machine.

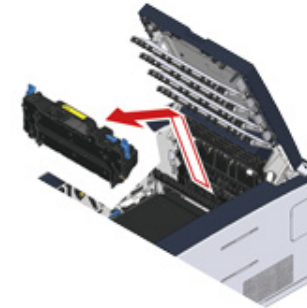

- 8 Turn the lock levers on the both sides of the belt unit toward you and remove the belt unit by holding the lock levers.



- 9 Remove the jammed paper slowly by pulling the edge of paper.



- 10 Hold the lock levers of belt unit and place the belt unit into the machine.

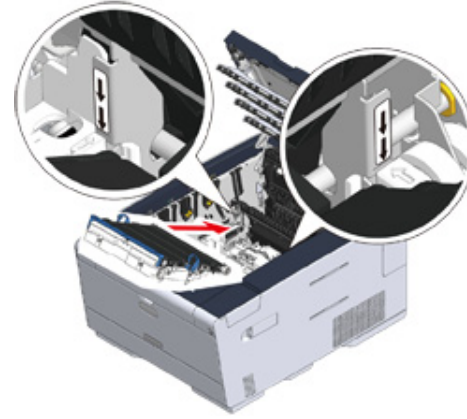

- 11 Turn the lock levers on the both sides of the belt unit forward.



- 12** Hold the fuser unit handle and place the fuser unit into the machine.

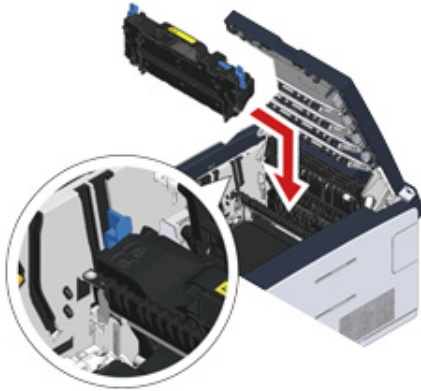

- 13** Tilt the lock levers on the both sides of the fuser unit.

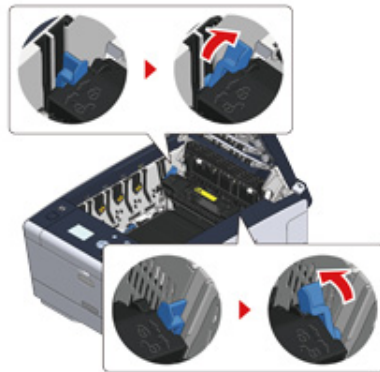

- 14** Replace the four image drums into the machine



- 15** Close the output tray (a) slowly and push the center of the output tray for confirmation.

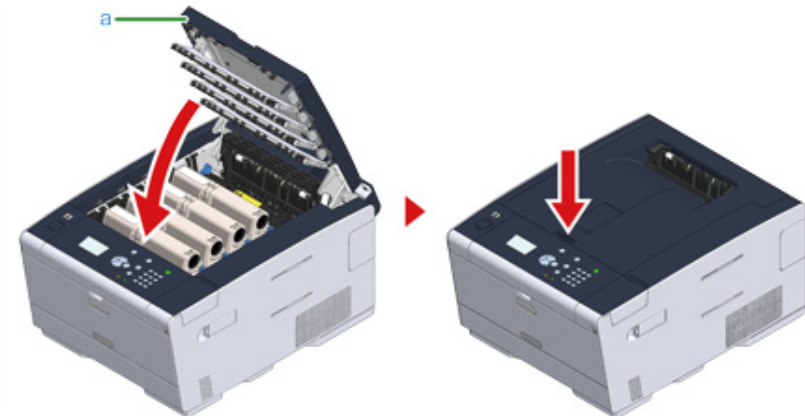

Task is complete.

If the Error Code is "380", "381", "382", "385", "389"

- 1 Press the button (A) and open the output tray (a) completely.

CAUTION

Burns may result.



The fuser unit is extremely hot. Do not touch it.

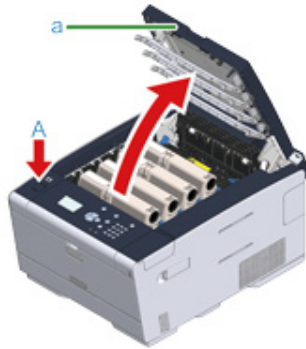

- 2 Remove the four image drums from the machine and place the image drums on a flat surface.



While removing consumables, be careful not to hit them to the LED head.

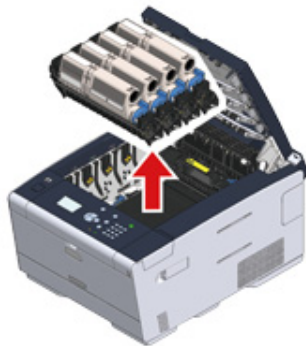

- 3 Cover the removed image drums with paper so that the image drums are not exposed to light.

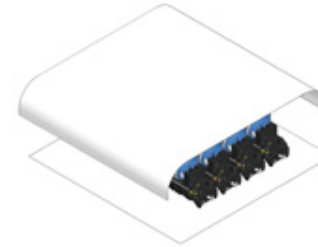

- 4 Remove the jammed paper slowly by pulling the edge of paper.



- 5 If paper jams in the fuser unit, press the jam release lever on the fuser unit and slowly pull the jammed paper toward you.



- 6 Tilt back the lock levers (c) on the both sides of the fuser unit toward you.

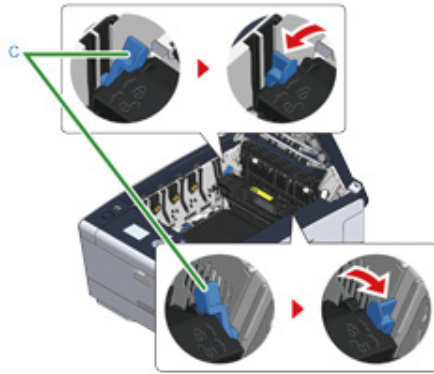

- 7 Hold the fuser unit handle and lift the fuser unit out of the machine.

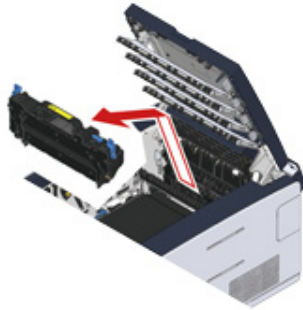

- 8 If jammed paper remains in the machine, hold the both sides of the paper to remove it gently.



- 9 Hold the fuser unit handle and place the fuser unit into the machine.

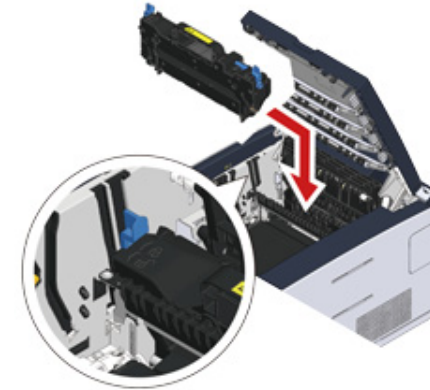

- 10 Tilt the lock levers (c) on the both sides of the fuser unit.

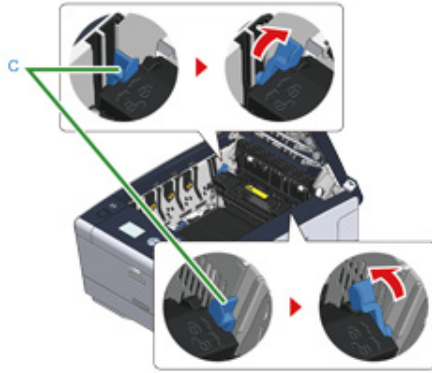

- 11 Put all four image drums back into the machine.

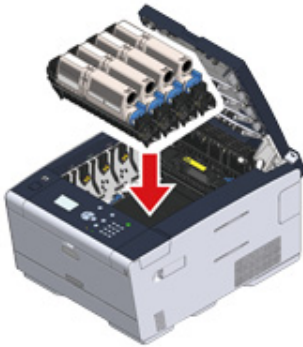

- 12 Close the output tray (a) slowly and push the center of the output tray for confirmation.

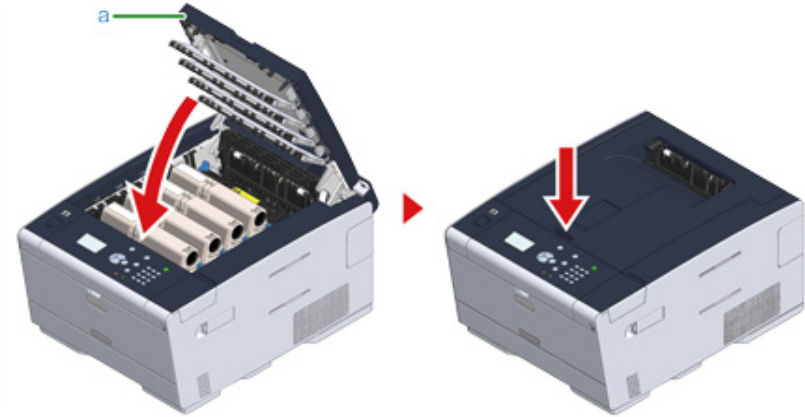

Task is complete.

If the Error Code is "390"

- 1 If paper is loaded on the MP tray, remove the paper.



- 2 Press the button (A) and open the output tray (a) completely.

CAUTION

Burns may result.



The fuser unit is extremely hot. Do not touch it.

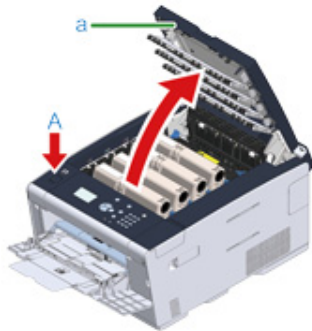

- 3 Remove the four image drums from the machine and place the image drums on a flat surface.



While removing consumables, be careful not to hit them to the LED head.

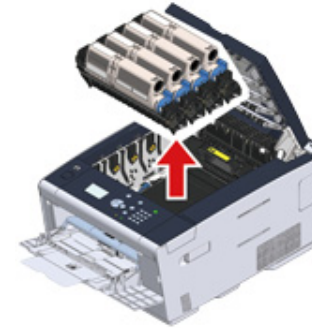

- 4 Cover the removed image drums with paper so that the image drums are not exposed to light.

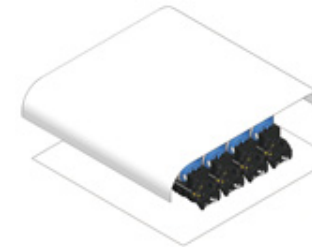

- 5 Open the transparent cover inside the machine, remove the jammed paper slowly by pulling the edge of paper.

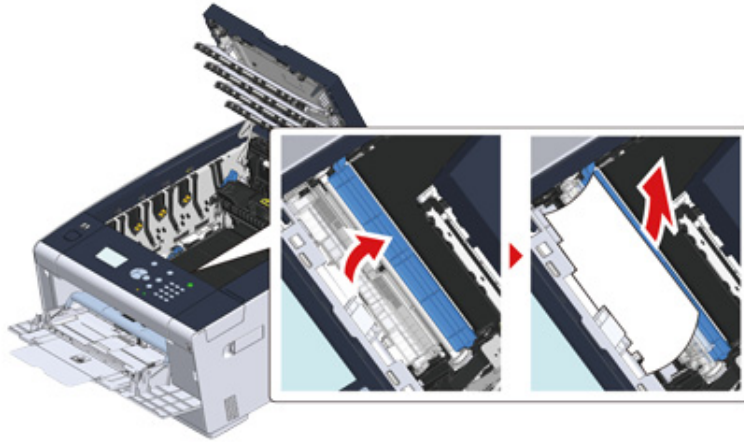

- 6 Put all four image drums back into the machine.

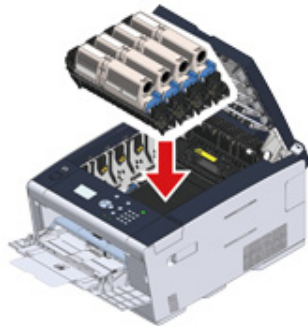

- 7 Close the output tray (a) slowly and push the center of the output tray for confirmation.

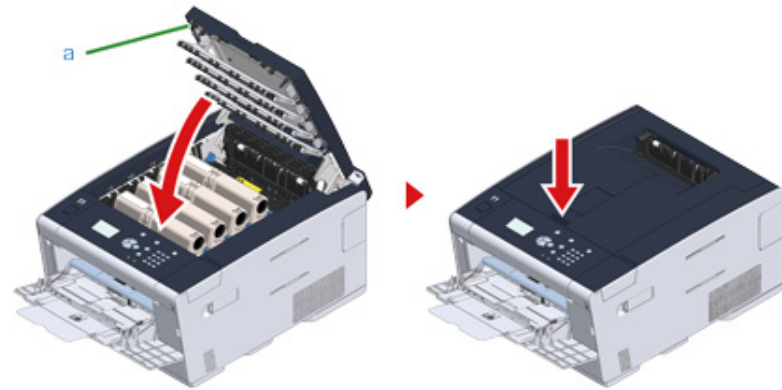

- 8 When loading paper on the MP tray, load the paper with the print side face up.

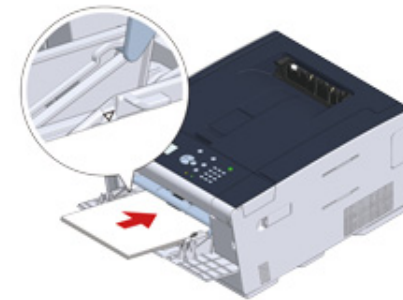

Task is complete.

If the Error Code is "391", "392", "393"

A paper jam has occurred while feeding paper from a paper tray.



If paper jams occur frequently, clean the paper feed rollers. For details, refer to "Cleaning the Paper Feed Rollers (Tray 1/Tray 2/Tray 3) (Advanced Manual)".

This procedure uses Tray 1 as an example.

- 1 Pull out the cassette of the indicated tray.



- 2 Remove the jammed paper.



If jammed paper cannot be found, check the positions of paper guides and paper stopper in the tray and ensure that paper is correctly loaded.

- 3 Replace the paper cassette into the machine.



- 4 Press the button (A) and open the output tray (a) completely.

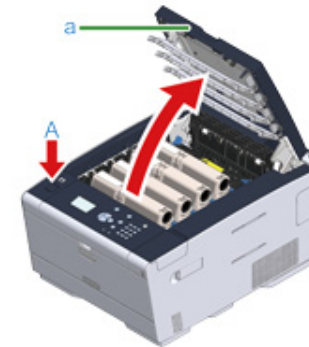

- 5 Close the output tray (a) slowly and push the center of the output tray for confirmation.

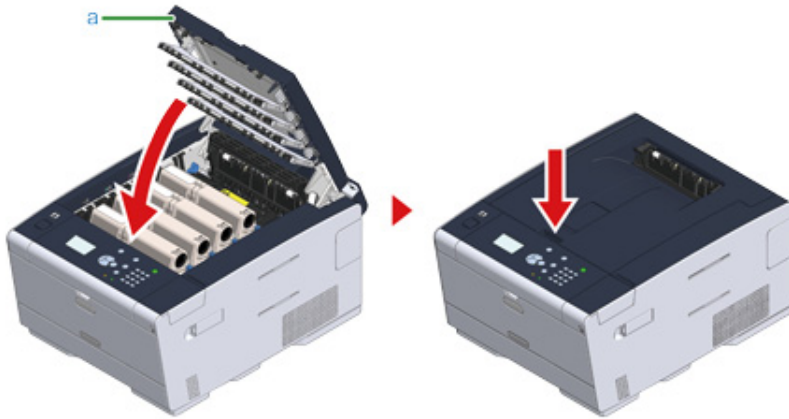

Task is complete.



Opening and closing the output tray starts printing.

If the Error Code is "409"

- 1 Close the rear output tray.



- 2 Press the button (A) and open the output tray (a) completely.



CAUTION

Burns may result.



The fuser unit is extremely hot. Do not touch it.

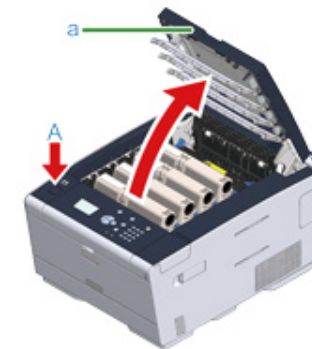

- 3 Remove the four image drums from the machine and place the image drums on a flat surface.



While removing consumables, be careful not to hit them to the LED head.



- 4 Cover the removed image drums with paper so that the image drums are not exposed to light.

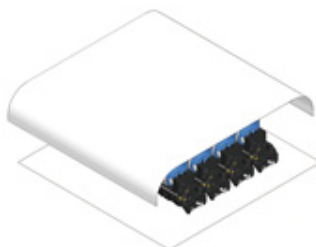

- 5 Remove the jammed paper slowly by pulling the edge of paper.



- 6 If paper jams in the fuser unit, press the jam release lever on the fuser unit and slowly pull the jammed paper toward you.



- 7 Tilt back the lock levers on the both sides of the fuser unit toward you.

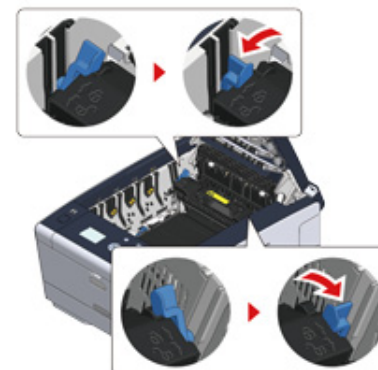

- 8 Hold the fuser unit handle and lift the fuser unit out of the machine.

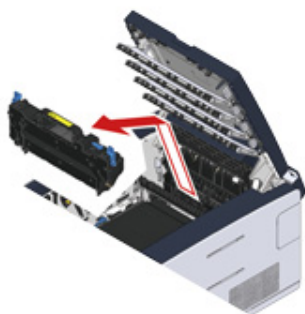

- 9 Tilt the lock levers on the both sides of the belt unit toward you and remove the belt unit by holding the lock levers.



- 10 Remove the jammed paper slowly by pulling the edge of paper.

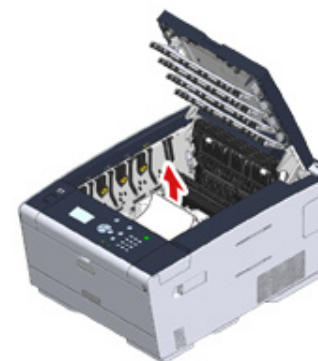

- 11 Hold the lock levers of belt unit and place the belt unit into the machine.

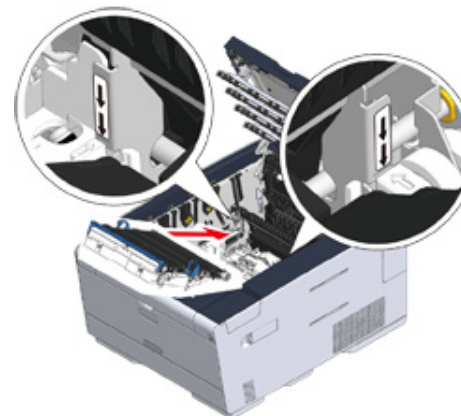

- 12** Turn the lock levers on the both sides of the belt unit forward.



- 13** Hold the fuser unit handle and place the fuser unit into the machine.

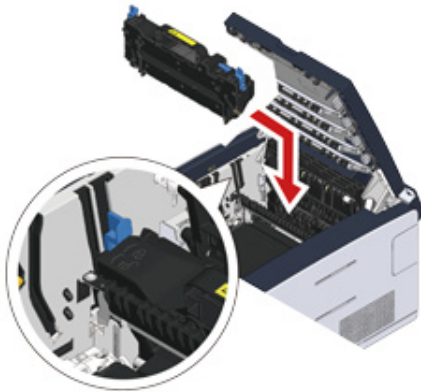

- 14** Tilt the lock levers on the both sides of the fuser unit.

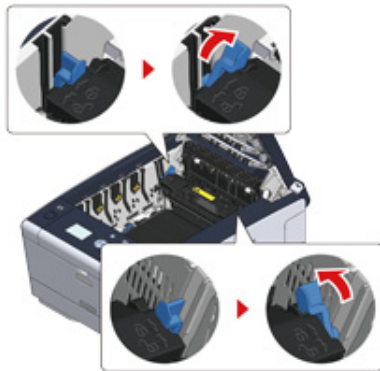

- 15** Put all four image drums back into the machine.



- 16** Close the output tray (a) slowly and push the center of the output tray for confirmation.

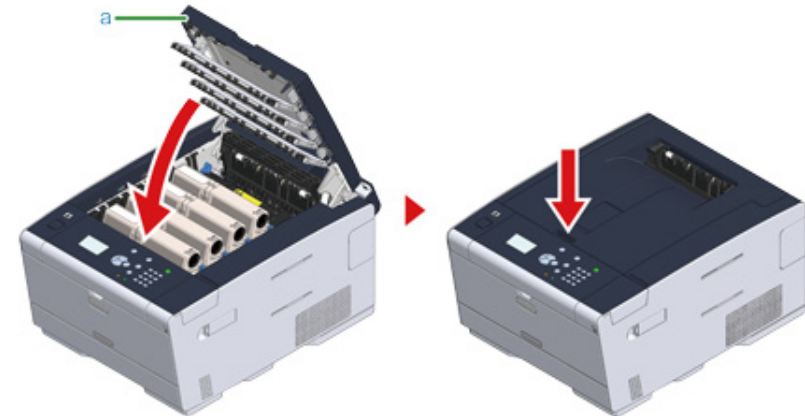

Task is complete.

Print Problems

This section describes problems with printing from a computer.













- If you cannot solve a problem with the following solutions, contact your dealer.
- For problems caused by an application, contact the manufacturer of the application.

• Unable to Print

- Network Connection Problems (Advanced Manual)
- Wireless LAN Connection Problems (Advanced Manual)
- USB Connection Problems (Advanced Manual)

Unable to Print

• Common to Windows and Mac OS X

Cause	Solution	Reference
The machine is in Sleep mode or Deep Sleep mode.	Press the  (POWER SAVE) button to enter standby status.	 Saving Power Consumption with the Power Save Function
The machine is turned off.	Turn the machine on.	 Turning the Machine On
A LAN cable or USB cable is unplugged.	Check that the cable is plugged into the machine and computer properly.	 Connecting a LAN Cable/USB Cable
There may be a problem with a cable.	Replace the cable with a new cable.	-
The machine is offline.	Press the  (ONLINE) button on the operator panel.	-
An error message is displayed on the display screen.	Check the error messages displayed on the display screen.	 Error Message List
The interface setting is disabled.	Check the interface setting on the display screen to make sure that there is a consistency with the machine's settings and the network connection environment.	 Connecting a LAN Cable/USB Cable  Connecting to a Wireless LAN (Only When the Wireless LAN Module is Mounted)
There is a problem with the print function.	Press the  or  button on the operator panel to select [Setting] > [Reports] > [Configuration] and print the menu map, by which you can check the printing performance.	 Printing a Report to Check (Advanced Manual)
The ONLINE lamp quickly flashes at approximately 0.3-second intervals.	A malfunction may occur in the machine. Unplug the power cord immediately, and then contact your dealer.	-



• For Windows

Cause	Solution	Reference
The machine is not set as the default printer.	Set the machine as the default printer. Right-click the [OKI C532 *] icon on the [Devices and Printers] folder, and then select [Set as Default Printer]. * Indicates the driver type. (ex. PCL6/PS/XPS)	-

Cause	Solution	Reference
The output port of the printer driver is incorrect.	Select the output port for connecting the LAN cable or USB cable.	-
The machine is processing data from another interface.	Wait until printing is complete.	-
[Receiving data timeout] or [Invalid Data] is displayed on the operator panel and the machine does not print.	<p>Press the ▲ or ▼ button on the operator panel to select [Setting] > [Admin Setup] > [Print Setup] > [Print Menu] > [Printer Adjust] > [Timeout Injob] and set a longer period of time. The factory default setting is 40 seconds.</p> <p>If the job is not printed with "Received invalid data" displayed, the selected emulation language may not match this machine (model). Make sure that the printer driver you use supports this model of the machine.</p>	-

If an Error Message is Displayed on the Operator Panel

If an error occurs in this machine, an error message and/or an error code (a 3-digit number) is displayed on the display screen and the  (ATTENTION) indicator on the operator panel blinks or lights up.

If you are not sure how to solve a problem, enter the error message or error code into "[Error Message List](#)", and then check the error cause and its solution.

- [Error Message List](#)

Error Message List

Wait a Moment. Network Initializing.

The network is being initialized.
Wait for a while until the machine connects to the network.

Checking File System

File system in the hard disk is being checked. Wait for a while.

PU Flash Error

Turn the machine off, and then back on. If the same error occurs, contact your dealer.

Communication Error

Turn the machine off, and then back on. If the same error occurs, contact your dealer.

Offline

The machine is offline. Press the  (ONLINE) button to set it to [Online].

Data Present

Data remains unprinted. Wait for a while and if the message does not disappear, check the data.

Cancelling Job

The job was cancelled or user is unauthorized. Wait for a while.

Adjusting Temp.

The machine is adjusting the temperature of the fuser unit. Wait for a while.

Color Adjusting

Color registration and density are being adjusted. Wait for a while.

Please wait Executing Maintenance

The programs on the machine are being updated.
Do not turn the machine off until the update completes.
The machine automatically restarts after the update completes.

[COLOR] Toner Low

The toner indicated on the screen is low. Have a new toner cartridge ready.
C: Cyan (blue), M: Magenta (red), Y: Yellow, K: Black

[COLOR] Waste Toner Full. Replace Toner.

Waste toner is full. Replace the toner cartridge with a new one.
C: Cyan (blue), M: Magenta (red), Y: Yellow, K: Black

[COLOR] Non Recommended Toner Detected.

Non-optimum toner cartridge is installed.
Use a toner cartridge that matches your machine.
C: Cyan (blue), M: Magenta (red), Y: Yellow, K: Black

[COLOR] Non Recommended Toner.

Non-optimum toner cartridge is installed.
Use a toner cartridge that matches your machine.
C: Cyan (blue), M: Magenta (red), Y: Yellow, K: Black

Error Postscript

A postscript error has occurred. Please check data.

[COLOR] Image Drum Near Life

The image drum indicated on the screen is near life. Have a new image drum ready.
C: Cyan (blue), M: Magenta (red), Y: Yellow, K: Black

Fuser Unit Near Life

The fuser unit is near life. Have a new fuser unit ready.

Belt Unit Near Life

The belt unit is near life. Have a new belt unit ready.

Change Fuser Unit

The fuser unit reaches its lifetime.
Replace the fuser unit with a new one.

Change Belt Unit

The belt unit reaches its lifetime.
Replace the belt unit with a new one.

[COLOR] Toner Empty

The toner indicated on the screen is empty. Replace the empty toner cartridge with a new one.
C: Cyan (blue), M: Magenta (red), Y: Yellow, K: Black

[COLOR] Toner Not Installed.

A color toner cartridge indicated on the screen is not installed.
Install the toner cartridge.
C: Cyan (blue), M: Magenta (red), Y: Yellow, K: Black

[COLOR] Image Drum Life

The image drum indicated on the screen reaches its lifetime.
Replace the image drum with a new one.
C: Cyan (blue), M: Magenta (red), Y: Yellow, K: Black

[TRAY] Empty

No paper is loaded in the indicated tray. Load paper.

File System is Full

Memory in the file system is full.
Delete unnecessary files.

File System is Write Protected

The file you are trying to write is write-protected.
Contact the device administrator.

Collate Fail: Too Many Pages

Insufficient memory error has occurred during collate printing.
Reduce the number of pages to print.

Unauthorized user, job cancelled.

Unauthorized user attempted to print. Data was deleted. Contact your administrator to use this machine.

File Erasing

Stored document files are being deleted.
Wait for a while.

Erased Data Full

Files supposed to be deleted are full. Erase the files.

Expired Secure Job

Expired saved files have been deleted.

File System Operation failed.

An error has occurred in the file system. Press the  (ONLINE) button.

Flash Error

An error has occurred when firmware was being updated.
Contact the administrator.

Invalid Secure Data

Invalid print data was received. To erase the message, press the  (ONLINE) button.
If you performed private printing, the data was deleted because it was incomplete. Print again.

Invalid Data

Invalid data received. Press the  (ONLINE) button to remove this message. If you performed private printing, the data was deleted because it was incomplete. Print again.

Received data has been discarded because Job Type is restricted.

Data whose job type is not defined in the acceptable job type settings was received. The data was discarded without being processed.

Select a job type defined in the acceptable job type settings for [Job Type] of the printer driver and print again.

[About Screens and Functions of Each Printer Driver](#)

Install Paper. MPTray.

Print on paper fed manually. Load paper in the MP tray.

Change Paper in [TRAY]. [MEDIA_SIZE] [MEDIA_TYPE] Error: 461, 462, 463

The size and type of paper set in the machine do not match those indicated on the screen. Use the same size and type of paper selected on the application.

Change Paper in MPTray. [MEDIA_SIZE] [MEDIA_TYPE] Error:460

The size or type of paper loaded in the MP tray do not match those indicated on the screen. Make sure that the size and type of paper loaded in the MP tray match those selected on the application.

Wait a moment. Network Configuration writing.

Network settings for this machine is changed. The new settings are being stored. Wait for a while.

Wait a Moment. Network Initializing.

Network settings for this machine are initializing.

Install Paper. [TRAY] [MEDIA_SIZE] Error: 490, 491, 492, 493

No paper is loaded in the indicated tray. Load paper of the displayed size.

Install Paper Cassette. [TRAY] Error: 440, 441, 430, 431, 432

The tray is not installed. Install the cassette. If the cassette is already inserted, pull it out, and then insert it again.

Press ONLINE Button for Restoration. Memory Overflow. Error: 420

Data is too complicated. Memory full error has occurred during processing. Reduce the volume of the print data.

Replace Toner. [COLOR] Waste Toner Full. Error: 414, 415, 416, 417

Waste toner of the toner cartridge is full. Opening and closing the output tray can resume printing for a while, but it may damage the image drum. Replace the toner cartridge with a new one as soon as possible.

C: Cyan (blue), M: Magenta (red), Y: Yellow, K: Black

Install Toner [COLOR] Error: 410, 411, 412, 413

The indicated cartridge ran out of toner.

Opening and closing the output tray can resume printing for a while, but it may damage the image drum. Replace the toner cartridge with a new one as soon as possible.

C: Cyan (blue), M: Magenta (red), Y: Yellow, K: Black

Non Recommended Toner C Error: 552, 556, 616, 622

The installed C (Cyan, blue) toner cartridge is not optimum.

We recommend using an optimum toner cartridge.

Non Recommended Toner M Error: 551, 555, 615, 621

The installed M (Magenta, red) toner cartridge is not optimum.

We recommend using an optimum toner cartridge.

Non Recommended Toner Y Error: 550, 554, 614, 620

The installed Y (Yellow) toner cartridge is not optimum.

We recommend using an optimum toner cartridge.

Non Recommended Toner K Error: 553, 557, 617, 623

The installed K (Black) toner cartridge is not optimum.

We recommend using an optimum toner cartridge.

Toner Not Installed [COLOR] Error: 610, 611, 612, 613

A color toner cartridge indicated on the screen is not installed.

Install the toner cartridge.

C: Cyan (blue), M: Magenta (red), Y: Yellow, K: Black

Image Drum Sensor Error [COLOR] Error: 540, 541, 542, 543

The image drum sensor error has occurred in the image drum indicated on the screen.

Uninstall the image drum, and then install it again.

If the message persists, uninstall the toner cartridge and install it again.

If the toner cartridge is not installed, install it.

C: Cyan (blue), M: Magenta (red), Y: Yellow, K: Black

Check Paper. Paper Size Error [TRAY]Error: 400

Paper size error has occurred in the indicated tray. Make sure that the size of paper loaded in the tray matches the [Paper Size] setting set on the operator panel. Load paper according to the paper size and direction set. To resume printing, open and close the output tray. If the setting made on the operator panel is wrong, cancel printing first, set the right paper size from [Paper Size] on the operator panel, and then print again.

Make sure that the cassette does not feed multiple sheets of paper at a time after starting printing. If it happens, remove paper, and then load paper correctly.

Open Cover. Paper Jam. Output Tray. Error: 390

Paper jammed via the paper feed path from the MP tray.

If the edge of the jammed paper is not visible, open the output tray and remove the paper.

Open Cassette. Paper Jam. [TRAY] Error: 391, 392, 393

A paper jammed via the paper feed path from the indicated tray.

Pull out the cassette, and then remove paper. If multiple sheets of paper are fed at a time, remove paper and reload paper.

Make sure that the paper stoppers are set in the right position.

Open Cover. Paper Jam. Output Tray. Error: 380, 381, 382, 385, 389

A paper jam has occurred inside the machine.

Open the output tray and remove jammed paper.

Open Cover. Paper Jam. Output Tray Error: 370, 371, 372

A paper jam has occurred inside the machine.

Open the output tray and remove jammed paper.

Install New Image Drum. Image Drum Life. [COLOR]. Error: 350, 351, 352, 353

The image drum indicated on the screen reaches its lifetime.
 Replace the image drum with a new one.
 Opening and closing the cover can resume printing for a while. Replace with a new one as soon as possible, however.
 C: Cyan (blue), M: Magenta (red), Y: Yellow, K: Black

Install New Image Drum. Image Drum Life. [COLOR] Error: 560, 561, 562, 563

The image drum indicated on the screen reaches its lifetime.
 Replace the image drum with a new one.
 C: Cyan (blue), M: Magenta (red), Y: Yellow, K: Black

Install New Image Drum. Image Drum Life. [COLOR] To Exceed the Life, Press Online Button. Error: 564, 565, 566, 567

The image drum indicated on the screen reaches its lifetime.
 Replace the image drum with a new one.
 C: Cyan (blue), M: Magenta (red), Y: Yellow, K: Black

Install New Image Drum. Printing disabled due to low threshold of Image Drum life. [COLOR] Error: 680, 681, 682, 683

Printing has stopped because the image drum indicated on the screen reached its lifetime. Replace with a new image drum to print.
 C: Cyan (blue), M: Magenta (red), Y: Yellow, K: Black

Install New Fuser Unit. Fuser Unit Life Error: 354

The fuser unit reaches its lifetime.
 Replace the fuser unit with a new one.
 Opening and closing the output tray can resume printing for a while. Replace with a new one as soon as possible for maintaining the print quality.

Install New Belt Unit. Belt Unit Life. Error: 355

The belt unit reaches its lifetime.
 Replace the belt unit with a new one.
 Opening and closing the output tray can resume printing for a while. Replace with a new one as soon as possible for maintaining the print quality.

Install New Belt Unit. Belt Unit Life. Error: 356

Waste toner of the belt unit is full. Replace the belt unit with a new one. Opening and closing the output tray can resume printing for a while. Replace with a new one as soon as possible for maintaining the print quality.

Check Toner Cartridge. Improper Lock Lever Position. Error: 544, 545, 546, 547

A color toner cartridge indicated on the screen is not installed.
 Make sure that the lever on the toner cartridge is fully turned and the protective tape is removed.
 C: Cyan (blue), M: Magenta (red), Y: Yellow, K: Black

Check Image Drum [COLOR] Error: 340, 341, 342, 343

The indicated image drum is not installed correctly.
 Remove and re-install the image drum.
 C: Cyan (blue), M: Magenta (red), Y: Yellow, K: Black

Check Fuser Unit Error: 320

The fuser unit is not properly installed. Remove and re-install the fuser unit.

Check Belt Unit Error: 330

The belt unit is not properly installed. Remove and re-install the belt unit.

Close Cover [COVER] Error: 310

Indicated cover is open. Close the cover.
 Error: 310 The output tray.

Power Off/On

Turn the machine off, and then back on.
 If the same error occurs, contact your dealer.

Service Call.

Turn the machine off, and then back on.
 If the same error occurs, contact your dealer.

Please check SMTP settings.

Cannot connect to the SMTP server. Check the network settings.

Please check POP3 settings.

Cannot connect to the POP3 server. Check the network settings.

SMTP Login failed.

An attempt to log into the SMTP server ended up an authentication error.
Check the network settings.

SMTP Auth. Unsupported

The SMTP server does not support the authentication system.
Check the network settings.

POP3 Login failed.

An attempt to log into the POP3 server ended up an authentication error.
Check the network settings.

Getting target IP failed. Please Check DHCP settings.

The DHCP server cannot be detected. Check the network connection.

Please check DNS settings.

Cannot connect to the DNS server. Check the network connection.

Please insert USB Memory.

Print from USB Memory was attempted with USB Memory not inserted.
Insert USB Memory.

[TRAY] cassette missing.

The cassette in the indicated tray is pulled out.
Install the cassette.

Color Restricted. Mono Printed.

A color print job was converted to a mono print job due to an unauthorized user. Contact your administrator for color printing.

Color Restricted. Job Rejected.

A color print job was deleted due to an unauthorized user. Contact your administrator for color printing.

Print Restricted. Job Rejected.

A print job was deleted due to an unauthorized user. Contact your administrator for printing.

Unsupported USB Device Detected. Please detach it.

An unsupported USB device is connected. Remove the USB device.

Incompatible USB device connected. Please detach it.

The connected USB device was not recognized. Remove the USB device.

USB Hub Unsupported.

A USB hub is connected. Remove the USB hub. This machine does not support USB hub.

Job Log Database Error

A data base access error has occurred while writing or reading the job log. Turning the machine off and on may resolve the problem.
To erase the message, press [Close].

Job Log Buffer Full (Delete old logs)

Old job logs were deleted, because job log buffer was full.

Decode error occurred.

An error has occurred in the image data sent to this machine. Check the image data.

Process has been canceled as there is no space on the device. Please free up enough memory space by reducing usage and try again.

Processing data was cancelled due to memory full.
Reduce the usage on the device to ensure available memory, and then retry.

Process has been canceled by a device error. After maintenance or change of the device, please try again.

Processing data was cancelled because an error occurred on the device.
Repair or replace the device, and then retry.

Deleting data.

This machine ran out of color toner. Color print data is being deleted.
Wait for a while.

Color toner empty. Job cancelled

The print data was cancelled because color toner is empty. To delete the message, press the  (ONLINE) button.

Error PDF

The PDF file is damaged.
Check the file.

Invalid Password

This PDF file is password protected.

Password required to print

This PDF needs authentication. Enter a password to print.

No communication with the SNTP server.

Obtaining current time from the SNTP server failed. Check the server.

Can not read the file

The USB Memory was removed while printing from USB Memory. Do not remove USB Memory while printing is in progress.

Cannot open the file.

The specified file could not be Opened. Check the file.

Cannot read the file.

Files could not be read. Check the device where the files are stored.

Getting the list ...

Data is being read from USB Memory.
Press the Stop button to cancel reading.

[COLOR] Image Drum Sensor Error

A sensor error has occurred in the image drum indicated on the screen.
Uninstall the image drum, and then install it again.
If the message persists, uninstall the toner cartridge and install it again.
C: Cyan (blue), M: Magenta (red), Y: Yellow, K: Black

Rear Output Tray Open. Duplex Not Available Error code: 581

2-sided printing failed because the rear output tray is open.
Close the rear output tray and tray again.

Open Output Tray. Rear Output Tray Error. Error code: 409

The rear output tray was moved while duplex printing.
Close the rear output tray and remove the jammed paper remaining inside of the unit.

Wait Timeout in menu is disabled.

Wait Timeout is disabled.
Press [Functions], select [Setting] > [Admin Setup] > [Print Setup] > [Print menu] > [Printer Adjust] > [Timeout Injob] on the operator panel, and then select a longer print timeout value.

Wireless setting are incomplete

Wrong values are set or items remain unset in the wireless LAN settings. Check the wireless settings.

Not connected to wireless access point

No wireless LAN access points are found.
Make sure that the access point is turned on.
Disconnect and re-connect to wireless LAN.

Wireless startup failed

Turn the machine off, check that the wireless LAN module is correctly installed, and then reboot the machine. If the error persists, contact your dealer.

Firmware Update Error. Please try again. If network doesn't work, please try firmware update over USB

Updating the firmware failed. Update again.

Registering with Google Cloud Print. Don't turn off the power until registration is complete.

This machine is being registered to the Google Cloud Print service. Wait for a while.



Deleting from Google Cloud Print.

This machine is being removed from the Google Cloud Print service. Wait for a while.

Caution, unknown Consumable detected

You can use any consumables in your product, but you must accept the risks of using non-genuine consumables. If the use of non-genuine consumables causes damage to the product or results in your product not functioning to its full specification, then such damage or effect on the product is not covered by warranty.

To accept these risks and to restore function;

- (1) Turn off your product.**
- (2) Press and hold the  (CLEAR) button and turn your product on.**
- (3) After start up, release the  (CLEAR) button.**

Note: This operation will be recorded for future reference.

[COLOR] Image Drum Life. [PAGES] Pages Left.

The image drum indicated on the screen reaches its lifetime.
Replace the image drum with a new one.
C: Cyan (blue), M: Magenta (red), Y: Yellow, K: Black

IPv4 address is conflicted. Please change IPv4 address.

The IP address assigned to this machine is duplicated with that of another device.
Check the IP addresses, and then assign another IP address.

Duplex Print Failed.

Duplex printing is not available on the specified paper.
Check the size and thickness of paper.

Changing Language. Panel operation is disabled.

Display language is being changed.
Wait for a while.

Language Change Failed. Error num: %CODE%

Switching display languages failed. Press the  (POWER) button to turn the machine off, and then back on.

Detected an abnormality of internal database. The data must be deleted. After pressing [Format], the data will be deleted, and then reboot.

Data base is beyond restoration.
To delete the data base, press [Format].

Summary Account balance is 0. [USERNAME] [ACCOUNTNAME] Increase the balance and press [Enter]. Press [Cancel] to cancel.

The number of print jobs exceeds the limit. No more print jobs are authorized. Contact your administrator.

7

Operating Management/ Specifications

Changing the Administrator Password

Saving Power Consumption with the Power Save Function

Specifications

This section describes how to manage the machine and its specifications.

Changing the Administrator Password

It is recommended to change the administrator password to protect your security. Set the administrator password using from 6 to 12 alphanumeric characters. Be careful not to forget the set password.

- 1 Press the ▼ button to select [Setting] and press the ↵ (ENTER) button.
- 2 Press the ▼ button several times to select [Admin Setup] and press the ↵ (ENTER) button.
- 3 Enter the administrator password, and then press ↵ (ENTER).
The factory default password is "999999".
- 4 Press the ▼ button several times to select [Manage Unit] and press the ↵ (ENTER) button.
- 5 Press the ▼ button several times to select [Admin Password] and press the ↵ (ENTER) button.
- 6 Enter a new administrator password and press the ↵ (ENTER) button.
- 7 Enter the new administrator password again and press the ↵ (ENTER) button.
- 8 Press the ◀ (BACK) button to display the [Ready To Print] screen.

Saving Power Consumption with the Power Save Function

The machine has three Power Save modes: Power Save, Sleep, and Deep Sleep.

In Power Save mode, the display screen turns off and the power saving indicator lights up or blinks.

Press the  (POWER SAVE) button to enter Power Save mode.

After being left unoperated for a certain period of time (a minute by factory default), the machine automatically enters Power Save mode.

After being left unoperated for a certain period of time (15 minutes by factory default) in Power Save mode, the machine enters Sleep mode, Deep Sleep mode.

















- For details on how to change the idle time before entering Power Save mode, see "[Setting the Length of Idle Time Before Entering Power Save Mode](#)".
- For details on how to change the idle time before entering Sleep mode, see "[Setting the Length of Idle Time Before Entering Sleep Mode](#)".







Press the  (POWER SAVE) button to recover from Power Save mode. The machine also recovers from Power Save mode, when some data is received from a computer or another device.

- [Setting the Length of Idle Time Before Entering Power Save Mode](#)
- [Setting the Length of Idle Time Before Entering Sleep Mode](#)
- [Restrictions in Power Saving Function](#)
- [Automatically Turning the Machine Off \(Auto Power Off\)](#)
- [Setting the Length of Idle Time Before Auto Power Off Works](#)

Setting the Length of Idle Time Before Entering Power Save Mode

- 1 Press the  button to select [Setting] and press the  (ENTER) button.
- 2 Press the  button several times to select [Admin Setup] and press the  (ENTER) button.
- 3 Enter the administrator password, and then press  (ENTER).
The factory default password is "999999".
- 4 Press the  button several times to select [Manage Unit] and press the  (ENTER) button.
- 5 Press the  button several times to select [Power Save] and press the  (ENTER) button.
- 6 Make sure that [Power Save Time] is selected, and then press the  (ENTER) button.
- 7 Press the  or  button to select time you want to set and press the  (ENTER) button.
- 8 Make sure that [*] is displayed on the left of the set time.
- 9 Press the  (BACK) button to display the [Ready To Print] screen.

Setting the Length of Idle Time Before Entering Sleep Mode

- 1 Press the ▼ button to select [Setting] and press the  (ENTER) button.
- 2 Press the ▼ button several times to select [Admin Setup] and press the  (ENTER) button.
- 3 Enter the administrator password, and then press  (ENTER).
The factory default password is "999999".
- 4 Press the ▼ button several times to select [Manage Unit] and press the  (ENTER) button.
- 5 Press the ▼ button several times to select [Power Save] and press the  (ENTER) button.
- 6 Press the ▼ button several times to select [Sleep Time] and press the  (ENTER) button.
- 7 Press the ▼ or ▲ button to select time you want to set and press the  (ENTER) button.
- 8 Make sure that [*] is displayed on the left of the set time.
- 9 Press the ◀ (BACK) button to display the [Ready To Print] screen.

Restrictions in Power Saving Function

The machine does not enter Sleep mode in the following case.

- When an error occurs on the machine
- Access Control in the Access Control settings is enabled and Local IC Card or LDAP IC Card in the Authentication Method is enabled.

The machine does not enter Deep Sleep mode in the following cases.

- IPsec is enabled
- A TCP connection is established
Example: A connection is established with Telnet or FTP.
When the transition time to enter Sleep mode or Deep Sleep mode from Power Save mode elapses and the connection is disconnected, the machine enters Sleep mode.
- E-mail reception is enabled
- Wireless LAN is enabled
- Google Cloud Print is enabled
- LLTD is enabled
- IPv6 Global Address is assigned

In Deep Sleep mode, you cannot use the following protocols to print.

- NBT

In Deep Sleep mode, you cannot search or set by using the following functions and protocols.

- NBT

In Deep Sleep mode, the following protocols that have the client function do not operate.

- E-mail alert*²
- SNMP Trap
- WINS*¹
- SNTP*²

- *¹ The elapse time in Deep Sleep mode is not included in the intervals of WINS update time.
WINS regular updates are not performed in Deep Sleep mode, possibly resulting in names that are registered in the WINS server being deleted.

- *2 The elapse time in Deep Sleep mode is not included in the intervals of the e-mail alert notification time and the intervals of the NTP server update time.

In a network environment where a large number of packets are sent, the machine automatically exits Deep Sleep mode to Sleep mode and responds.

Also, if a terminal that runs searches with Bonjour, such as Mac or iPhone, is connected to the same network, the machine automatically exits Deep Sleep mode to Sleep mode and responds.

This machine automatically enters Deep Sleep mode after a certain period of time.

Automatically Turning the Machine Off (Auto Power Off)

The machine equipped with the Auto Power Off function which automatically turns the power off if the machine is left unoperated for a certain period of time.

There are three options for the Auto Power Off setting and [Auto Config] is set by factory default.

- [Auto Config]: The machine automatically turns off after being left unoperated for a certain period of time unless the machine is in the following conditions.
 - A LAN cable is connected to the network interface connector.
 - Wireless LAN is enabled.
- [Enable]: If you do not use the machine for a certain period of time, the machine automatically turns off.
- [Disable]: Disables the Auto Power Off function. The machine does not automatically turn off.



The machine does not automatically turn off in the following case.







- When an error has occurred

Follow the steps below to change the Auto Power Off setting.

- 1 Press the ▼ button to select [Setting] and press the ⏏ (ENTER) button.
- 2 Press the ▼ button several times to select [Admin Setup] and press the ⏏ (ENTER) button.
- 3 Enter the administrator password, and then press the ⏏ (ENTER) button.
The factory default password is "999999".
- 4 Press the ▼ button several times to select [User Install] and press the ⏏ (ENTER) button.
- 5 Press the ▼ button several times to select [Power Setup] and press the ⏏ (ENTER) button.
- 6 Press the ▼ button several times to select [Auto Power Off] and press the ⏏ (ENTER) button.

- 7 Press the ▼ or ▲ button to select value you want to set and press the  (ENTER) button.
- 8 Make sure that [*] is displayed on the left of the set time.
- 9 Press the ◀ (BACK) button to display the [Ready To Print] screen.

Setting the Length of Idle Time Before Auto Power Off Works

- 1 Press the ▼ button to select [Setting] and press the  (ENTER) button.
- 2 Press the ▼ button several times to select [Admin Setup] and press the  (ENTER) button.
- 3 Enter the administrator password, and then press the  (ENTER) button.
The factory default password is "999999".
- 4 Press the ▼ button several times to select [Manage Unit] and press the  (ENTER) button.
- 5 Press the ▼ button several times to select [Power Save] and press the  (ENTER) button.
- 6 Press the ▼ button several times to select [Auto Power Off Time] and press the  (ENTER) button.
- 7 Press the ▼ or ▲ button to select time you want to set and press the  (ENTER) button.
- 8 Make sure that [*] is displayed on the left of the set time.
- 9 Press the ◀ (BACK) button to display the [Ready To Print] screen.

Specifications

This section describes the specifications of the machine.

- [General Specifications](#)
- [Printing Specifications](#)
- [Network Specifications](#)
- [Wireless LAN Specifications \(Option\)](#)

General Specifications

SFP Model	Model Number
C532/ES5432	N36301A/N36301B

Item	C532/ES5432	
CPU	ARM Processor (667MHz)	
Memory	DDR3 32bit 1GB	
ROM	3 GB	
Weight (including consumables)	23 kg	
Dimensions (W x D x H)	427 x 571 x 279 mm	
Power supply	N36301A: 120V AC +/-10 N36301B: 230V AC +/-10	
Power consumption	Typical operation	N36301A: 670 W / N36301B: 640 W
	Idle	90 W
	Peak	N36301A: 1220 W / N36301B: 1250 W
	Power save mode	Less than 14 W
	Sleep mode	Less than 7.8 W
	Deep sleep mode	Less than 1.1 W
	Auto power off mode	Less than 0.5 W
Operating condition	Operating	Temperature :10 - 32°C, Humidity : 20 - 80% RH
	Idle	Temperature : 0 - 43°C, Humidity : 10 - 90% RH
Interface	USB 2.0, Ethernet 10BASE-T/100BASE-TX/1000BASE-T, Host USBx2 IEEE802.11 b/g/n/a Wireless LAN (Option)	
Display	Graphic LCD panel, 60 (W) x 32.6 (H) mm, 128 x 64 dots	
Supported OS	Windows 10/Windows 8.1/Windows Server 2012 R2/ Windows 8/Windows Server 2012/Windows 7/ Windows Vista/Windows Server 2008 R2/Windows Server 2008 Mac OS X 10.8.5 to 10.11	

Printing Specifications

Item		C532/ES5432
Printing method		Dry electrophotographic recording method with LED (Light-emitting diode)
Emulation T		PostScript 3, PCL5c, PCL6 (XL), EPSON FX, IBM ProPrinter, XPS, PDF (v1.7 or earlier)
Resident fonts		PCL: 91 European fonts PS: 80 European fonts
Resolution		1200 x 1200 dpi, 600 x 600 dpi
Color		Yellow, Magenta, Cyan, Black
Print speed		<ul style="list-style-type: none"> A4 Simplex: Up to 30 ppm Duplex: Up to 16 ppm (mono), 14 ppm (color) Letter Simplex: Up to 31 ppm Duplex: Up to 16 ppm (mono), 14 ppm (color)
First print out time	Color	Approx. 7.5 seconds (A4)
	Mono	Approx. 7.5 seconds (A4)
Paper size	Tray 1	Legal 13/13.5/14, Letter, Executive, A4, A5, A6, B5, B6, Statement, 8.5 SQ, Folio, 16K (197 x 273 mm, 195 x 270 mm, 184 x 260 mm), Custom size
	Additional tray unit (Optional)	Legal 13/13.5/14, Letter, Executive, A4, A5, B5, 8.5 SQ, Folio, 16K (197 x 273 mm, 195 x 270 mm, 184 x 260 mm), Custom size
	MP Tray	Legal 13/13.5/14, Letter, Executive, A4, A5, A6, B5, B6, B6 Half, Statement, 8.5 SQ, Folio, Index card (3 x 5 inches), 4 x 6 inches, 5 x 7 inches, Banner up to 1321 mm (52 inches), 16K (197 x 273 mm, 195 x 270 mm, 184 x 260 mm), C5, DL, Com-9, Com-10, Monarch, Custom size
	Duplex Printing	Legal 13/13.5/14, Letter, Executive, A4, A5, B5, 8.5 SQ, Folio, 16K (197 x 273 mm, 195 x 270 mm, 184 x 260 mm), Custom size
	Custom size	<ul style="list-style-type: none"> Tray 1 100 - 216 mm (W), 148 - 356 mm (L) (3.9 - 8.5 inches (W), 5.8 - 14.0 inches (L)) Additional tray unit (optional) 148 - 216 mm (W), 210 - 356 mm (L) (5.8 - 8.5 inches (W), 8.3 - 14.0 inches (L)) MP tray 64 - 216 mm (W), 90 - 1321 mm (L) (2.5 - 8.5 inches (W), 3.5 - 52 inches (L)) Duplex 148 - 216 mm (W), 210 - 356 mm (L) (5.8 - 8.5 inches (W), 8.3 - 14.0 inches (L))
Media type		Plain paper (64 g/m ² - 220 g/m ²), Envelopes, Label
Feeding method		Automatic feeding from Tray 1, MP tray and Additional tray unit (optional) Manual feeding from MP tray

Item	C532/ES5432
Paper loading capacity	<ul style="list-style-type: none"> Tray 1 250 sheets (less than 80 g/m²), total thickness 25 mm or lower. MP tray 100 sheets (less than 80 g/m²) and total thickness 10 mm or lower, 10 envelopes (85 g/m²). Additional tray unit (optional) 530 sheets of Standard paper /80 g/m² and total thickness 53 mm or lower.
Output method	Output tray/Rear output tray
Paper output capacity	<ul style="list-style-type: none"> Output Tray 150 sheets (less than 80 g/m²) Rear Output Tray 100 sheets (less than 80 g/m²)
Print guaranteed area	6.35 mm or more from the paper edge (not applicable to special media such as envelopes)
Print precision	Print beginning: ± 2 mm, paper skew: ± 1 mm/100 mm Image expansion: ± 1 mm/100 mm (80 g/m ²)
Warm-up time	<ul style="list-style-type: none"> From power on 27 seconds (at room temperature 25°C, rated voltage) From sleep mode 35 seconds (at room temperature 25°C, rated voltage)
Usage Environment Conditions	<ul style="list-style-type: none"> When in operation 10 - 32°C/ Relative Humidity of 20 - 80% (maximum wet bulb temperature of 25°C, maximum dry bulb temperature of 2°C) When not in operation 0 - 43°C/ Relative Humidity of 10 - 90% (maximum wet bulb temperature of 26.8°C, maximum dry bulb temperature of 2°C)
Conditions for the guarantee of print quality	<ul style="list-style-type: none"> Operating Range Temperature 10°C, humidity 20 to 80% RH Temperature 32°C, humidity 20 to 60% RH Humidity 20% RH, temperature 10 to 32°C Humidity 80% RH, temperature 10 to 27°C Full-color Print Quality Assured Range Temperature 17 to 27°C, humidity 50 to 70% RH
Consumables	Toner cartridges, Image drums, Belt unit, Fuser unit

Network Specifications

Item	C532/ES5432
Interface	Ethernet 10BASE-T/100BASE-TX/1000BASE-T, IEEE802.11 a/b/g/n Wireless LAN
Protocol	TCP/IPv4, TCP/IPv6, NetBIOS over TCP, LPR, Port9100, IPP, FTP, HTTP, TELNET, SMTP, POP3, SNMPv1/v3, DHCP, DHCPv6, DNS, DDNS, UPnP, WINS, Bonjour, SNTP, LLTD, Web Services Discovery (WSD), SSL/TLS, IPSec, LDAPv3, Kerberos, IEEE802.1X, AirPrint, Google Cloud Print

Wireless LAN Specifications (Option)

Item	C532/ES5432
Wireless LAN standard	IEEE802.11a/b/g/n conformity (2.4 GHz / 5 GHz)
Security	Disable, WEP, WPA-PSK, WPA2-PSK, WPA-EAP, WPA2-EAP

Regulatory wireless LAN statements

- FCC Statement
- IC Statement
- Europe-CE Declaration of conformity.

FCC statement

FCC WARNING

Changes or modifications not expressly approved by the party responsible for compliance could void the user's authority to operate the equipment.

Note: This equipment has been tested and found to comply with the limits for a Class B digital device, pursuant to part 15 of the FCC Rules. These limits are designed to provide reasonable protection against harmful interference in a residential installation. This equipment generates, uses and can radiate radio frequency energy and, if not installed and used in accordance with the instructions, may cause harmful interference to radio communications. However, there is no guarantee that interference will not occur in a particular installation. If this equipment does cause harmful interference to radio or television reception, which can be determined by turning the equipment off and on, the user is encouraged to try to correct the interference by one or more of the following measures:

- Reorient or relocate the receiving antenna.
- Increase the separation between the equipment and receiver.
- Connect the equipment into an outlet on a circuit different from that to which the receiver is connected.
- Consult the dealer or an experienced radio/TV technician for help.

This transmitter must not be co-located or operating in conjunction with any other antenna or transmitter.

IC statement

This device complies with Part 15 of FCC Rules and Industry Canada licence-exempt RSS standard(s). Operation is subject to the following two conditions: (1) this device may not

cause interference, and (2) this device must accept any interference, including interference that may cause undesired operation of this device.

Le présent appareil est conforme aux la partie 15 des règles de la FCC et CNR d'Ubdustrie Canada applicables aux appareils radio exempts de licence. L'exploitation est autorisée aux deux conditions suivantes : (1) l'appareil ne doit pas produire de brouillage, et (2) l'utilisateur de l'appareil doit accepter tout brouillage radioélectrique subi, même si le brouillage est susceptible d'en compromettre le fonctionnement.

This Class [B] digital apparatus complies with Canadian ICES-003.

Cet appareil numérique de la classe [B] est conforme à la norme NMB-003 du Canada.

Caution (FCC/IC):

5.15-5.25 GHz band is restricted to indoor operations only.

La bande 5150-5250 MHz est restreints à une utilisation à l'intérieur.

This equipment complies with FCC/IC radiation exposure limits set forth for an uncontrolled environment and meets the FCC radio frequency (RF) Exposure Guidelines and RSS-102 of the IC radio frequency (RF) Exposure rules. This equipment should be installed and operated keeping the radiator at least 20 cm or more away from person's body.

Cet équipement est conforme aux limites d'exposition aux rayonnements énoncées pour un environnement non contrôlé et respecte les règles les radioélectriques (RF) de la FCC lignes directrices d'exposition et d'exposition aux fréquences radioélectriques (RF) CNR-102 de l'IC. Cet équipement doit être installé et utilisé en gardant une distance de 20 cm ou plus entre le dispositif rayonnant et le corps.

Europe - CE Declaration of Conformity



This equipment complies with the essential requirements of the European Union directive 2014/53/EU.

The telecommunications functionality of this product may be used in the following EU and EFTA countries: Austria, Belgium, Bulgaria, Cyprus, Czech Republic, Denmark, Estonia, Finland, France, Germany, Greece, Hungary, Iceland, Ireland, Italy, Latvia, Liechtenstein, Lithuania, Luxembourg, Malta, Netherlands, Norway, Poland, Portugal, Romania, Slovak Republic, Slovenia, Spain, Sweden, Switzerland, Turkey and United Kingdom.

Contact Us

Italia www.oki.com/it
Français www.oki.com/fr
Deutschland www.oki.com/de
United Kingdom www.oki.com/uk
Ireland www.oki.com/ie
España www.oki.com/es
Portuguesa www.oki.com/pt
Sverige www.oki.com/se
Danmark www.oki.com/dk
Norge www.oki.com/no
Suomi www.oki.com/fi
Nederland www.oki.com/nl
België/Belgique www.oki.com/be
Österreich www.oki.com/at
Schweiz/Suisse/Svizzera www.oki.com/ch
Polska www.oki.com/pl
Česká www.oki.com/cz
Slovenská www.oki.com/sk
Magyarország www.oki.com/hu
Россия www.oki.com/ru
Україна www.oki.com/ua
Türkiye'ye www.oki.com/tr
Serbia www.oki.com/rs
Croatia www.oki.com/hr
Greece www.oki.com/gr
Romania www.oki.com/ro
OKI Europe www.oki.com/eu

Singapore www.oki.com/sg/
Malaysia www.oki.com/my/
ประเทศไทย www.oki.com/th/printing/
Australia www.oki.com/au/
New Zealand www.oki.com/nz/
United States www.oki.com/us/
Canada www.oki.com/ca/
Brasil www.oki.com/br/printing
México www.oki.com/mx/
Argentina www.oki.com/la/
Colombia www.oki.com/la/
Other countries www.oki.com/printing/

