



User's Guide

- C801
- C810
- C821
- C830



PREFACE

Every effort has been made to ensure that the information in this document is complete, accurate, and up-to-date. The manufacturer assumes no responsibility for the results of errors beyond its control. The manufacturer also cannot guarantee that changes in software and equipment made by other manufacturers and referred to in this guide will not affect the applicability of the information in it. Mention of software products manufactured by other companies does not necessarily constitute endorsement by the manufacturer.

While all reasonable efforts have been made to make this document as accurate and helpful as possible, we make no warranty of any kind, expressed or implied, as to the accuracy or completeness of the information contained herein.

The most up-to-date drivers and manuals are available from:

<http://www.okiprintingsolutions.com>

07094301 Iss. 2; Copyright © 2010. All rights reserved.

Oki is a registered trademark of Oki Electric Industry Company, Ltd.

Oki Printing Solutions is a trademark of Oki Data Corporation.

Energy Star is a trademark of the United States Environmental Protection Agency.

Microsoft, MS-DOS and Windows are registered trademarks of Microsoft Corporation.

Apple, Macintosh, Mac and Mac OS are trademarks of Apple Inc.

Other product names and brand names are registered trademarks or trademarks of their proprietors.



As an Energy Star Program Participant, the manufacturer has determined that this product meets the Energy Star guidelines for energy efficiency.



This product complies with the requirements of the Council Directives 2004/108/EC (EMC), 2006/95/EC (LVD), 1999/5/EC (R&TTE) and 2009/125/EC (EuP) as amended where applicable, on the approximation of the laws of the member states relating to electromagnetic compatibility, low voltage, radio & telecommunications terminal equipment and energy using products.

The following cables were used to evaluate this product to achieve EMC directive 2004/108/EC compliance and configurations other than this may affect that compliance.

CABLE TYPE	LENGTH (METRE)	CORE	SHIELD
Power	2.0	x	x
USB	5.0	x	✓
LAN	15.0	x	x
Parallel	1.8	x	✓

Please note that Microsoft Windows XP was used to produce all screenshots in this manual. These screenshots may vary if you are using any other operating system, but the principle is the same.

EMERGENCY FIRST AID

Take care with toner powder:

If swallowed, give small amounts of cold water and seek medical attention. DO NOT attempt to induce vomiting.



If inhaled, move the person to an open area for fresh air. Seek medical attention.

If it gets into the eyes, flush with large amounts of water for at least 15 minutes keeping eyelids open. Seek medical attention.

Spillages should be treated with cold water and soap to help reduce risk of staining skin or clothing.

MANUFACTURER

Oki Data Corporation,
4-11-22 Shibaura, Minato-ku,
Tokyo 108-8551,
Japan

IMPORTER TO THE EU/AUTHORISED REPRESENTATIVE

Oki Europe Limited (trading as Oki Printing Solutions)

Oki Europe Limited
Blays House
Wick Road
Egham
Surrey TW20 0HJ
United Kingdom

For all sales, support and general enquiries contact your local distributor.

ENVIRONMENTAL INFORMATION



CONTENTS

Preface	2
Emergency first aid	3
Manufacturer	3
Importer to the EU/authorised representative	3
Environmental Information	3
Contents	4
Notes, cautions and warnings	7
Introduction	8
Printer overview	9
Front view	9
Rear view	10
Changing the display language	10
Paper recommendations	11
Cassette trays	12
Multi purpose tray	12
Face down stacker	12
Face up stacker	13
Duplex unit	13
Loading paper	14
Cassette trays	14
Multi purpose tray	16
Operation	18
C801 and C810	18
C821 and C830	18
Printing settings in Windows (C801 and C810 only)	19
Printing preferences in windows applications	19
Setup tab	19
Job options tab	20
Colour tab	21
Setting from windows control panel	22
General tab	22
Advanced tab	22
Printing settings in Mac OS X (C801 and C810 only)	24
Setting printing options	24
Setting printing options - saving driver settings	25
Changing the default printer and paper size	25
Page setup options	25
Print options	26
Copies & pages	26
Layout	26
Scheduler	27
Paper handling	27
ColorSync	28
Cover page	28
Duplex	28
Paper source	29
Print quality	29
Colour	30
Printer setup options	31
Printer options	31
Print control	32
Summary	32

Colour printing (C801 and C810 only)	33
Factors that affect the appearance of prints	33
Tips for printing in colour	34
Printing photographic images	34
Printing from Microsoft Office applications	34
Printing specific colours (e.g. a company logo)	34
Adjusting the brightness or intensity of a print	34
Accessing the colour matching options	34
Setting the colour matching options	35
Using the colour swatch feature	35
Using the colour correct utility	36
Menu functions - C801 and C810	37
Operator Panel	37
How to change the settings - User	37
How to change the settings - Administrator	38
Menus	39
Information menu	39
Shutdown menu	39
Print menu	39
Media menu	40
Colour menu	42
System configuration menu	42
Network menu	43
Maintenance menu	44
Usage menu	44
Administrator (Boot) menu	45
Print statistics menu	47
Menu functions - C821 and C830	48
Operator panel	48
How to change the settings - User	49
How to change the settings - Administrator	49
Configuration menu	50
Print information menu	51
Print secure job	52
Menus	53
Shutdown menu	55
Admin setup	56
Calibration	65
Administrator (boot) menu	66
Print statistics menu	69
Maintenance	70
Replacing consumable items	70
Toner cartridge replacement	70
Image drum replacement	73
Transfer belt replacement	76
Fuser replacement	78
Cleaning	80
...the unit casing	80
...the LED head	80
...the paper feed rollers	81
Installing upgrades	82
Duplex unit	83
Memory upgrade (C821 and C830)	84
Hard disk drive (C821 and C830)	87
Additional paper tray(s)	89
Storage cabinet	89

Adjusting printer drivers.	90
Windows	90
Mac OS X	90
Troubleshooting	92
Major printer components and paper path	92
Paper sensor error codes	93
Clearing paper jams	93
Dealing with unsatisfactory printing.	99
Specifications	101
Index.	102
Oki contact details.	103

NOTES, CAUTIONS AND WARNINGS

NOTE

A note provides additional information to supplement the main text.

CAUTION!

A caution provides additional information which, if ignored, may result in equipment malfunction or damage.

WARNING!

A warning provides additional information which, if ignored, may result in a risk of personal injury.

For the protection of your product, and in order to ensure that you benefit from its full functionality, this model has been designed to operate only with genuine original toner cartridges. Any other toner cartridge may not operate at all, even if it is described as "compatible", and if it does work, your product's performance and print quality may be degraded.

Non-genuine original products may invalidate your warranty.

Specifications subject to change without notice. All trademarks acknowledged.

INTRODUCTION

Congratulations on choosing this colour printer. Your new printer is designed with advanced features to give you clear, vibrant colour prints and crisp black and white pages at high speed on a range of print media for the office.

Your printer includes these features:

- > Compact A3 desktop footprint;
- > ProQ2400 multi-level technology produces subtler tones and smoother graduations of colour to lend photographic quality to your documents;
- > 600 x 600, 1200 x 600 dpi (dots per inch) and ProQ2400 print resolution for high quality image production showing the finest detail;
- > Single Pass colour Digital LED technology for high speed processing of your printed pages;
- > Profile Assistant utility allows you to download ICC profiles to the hard disc (Hard Disc Drive required) (C821 and C830);
- > PostScript 3, PCL 5C, PCL 6 and Epson FX emulations for industry standard operation and wide compatibility with most computer software (C821 and C830);
- > Secure encrypted printing (C821 and C830) - allows you to print confidential documents on printers that are shared with other users in a network environment;
- > 10Base-T and 100Base-TX network connection lets you share this valuable resource among users on your office network;
- > Photo Enhance mode to improve printouts of photographic images (not available on PS drivers).
- > "Ask Oki" – a user-friendly function for Windows that gives a direct link from your printer driver screen to a dedicated web site specific to the exact model you are using. This is where you'll find all the advice, assistance and support you could need to help you get the best possible results from your Oki printer;
- > Template Manager utility for Windows enables the design and print of Business cards, banners, labels with ease;

Additionally, the following optional features are also available:

- > Automatic two-sided (duplex) printing for economical use of paper and compact printing of larger documents (standard on dn models);
- > Additional paper trays for loading a further 530/1060 sheets to minimise operator intervention, or different paper stocks for letterhead stationery, alternative paper sizes or other print media;
- > Additional memory allows printing of more complex pages. For example, high resolution banner printing (C821 and C830);
- > Internal hard disk drive for Secure printing, storage of overlays, macros and downloadable fonts, and automatic collation of multiple copies of multipage documents and the download of ICC Profiles (C821 and C830);
- > Storage cabinet.

PRINTER OVERVIEW

FRONT VIEW

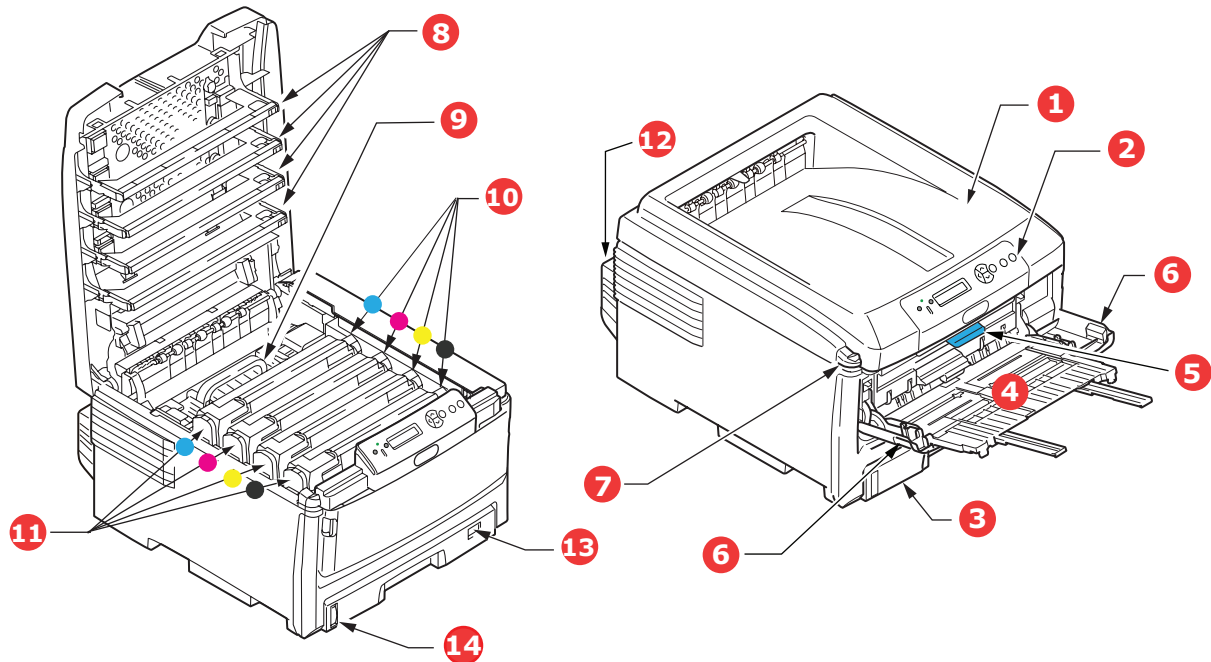

<p>1. Output stacker (face down). Standard printed copy delivery point. Holds up to 250 sheets at 80g/m².</p> <p>2. Operator panel. Menu driven operator controls and LCD display panel.</p> <p>3. Paper tray. Standard blank paper tray. Holds up to 300 sheets of 80g/m² paper.</p> <p>4. Multi purpose tray. Used for feeding heavier paper stocks, envelopes and other special media. Also for manual feeding of single sheets when required.</p>	<p>5. Front cover release lever.</p> <p>6. Multi-purpose tray release lever</p> <p>7. Top cover release button.</p> <p>8. LED heads</p> <p>9. Fuser</p> <p>10. Toner cartridges (C,M,Y,K).</p> <p>11. ID units (C,M,Y,Y).</p> <p>12. Duplex Unit (optional).</p> <p>13. Paper size dial.</p> <p>14. Paper level gauge.</p>
---	--

The LCD display language can be changed to show different languages. ([See "Changing the display language" on page 10.](#))

REAR VIEW

This view shows the connection panel, the rear output stacker and the location of the optional duplex (two-sided printing) unit.

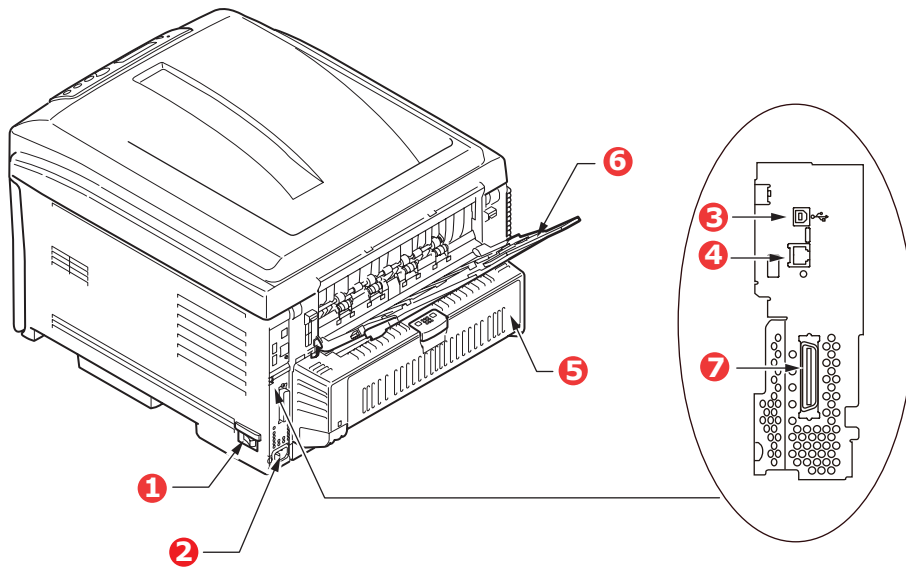

- | | |
|---|---|
| <ul style="list-style-type: none">1. ON/OFF switch.2. AC power socket.3. USB interface.4. Network interface.¹ | <ul style="list-style-type: none">5. Duplex unit (when fitted).6. Rear, face up, 100 sheet stacker.7. Parallel Port.² |
|---|---|

- 1. The Network Interface may have a protective "plug" which must be removed before connection can be made.
- 2. C821 and C830.

When the rear paper stacker is folded down paper exits the printer through the rear of the printer and is stacked here face up. This is mainly used for heavy print media. When used in conjunction with the multi purpose feed tray, the paper path through the printer is essentially straight. This avoids bending the paper around curves in the paper path and enables feeding of up to 220g/m² media.

CHANGING THE DISPLAY LANGUAGE

The default language used by your machine for display messages is English. If required, this can be changed using the Panel Language Set-up utility.

PAPER RECOMMENDATIONS

Your printer will handle a variety of print media, including a range of paper weights and sizes, transparencies and envelopes. This section provides general advice on choice of media, and explains how to use each type.

The best performance will be obtained when using standard 75~90g/m² paper designed for use in copiers and laser printers.

Use of heavily embossed or very rough textured paper is not recommended.

Pre-printed stationery

CAUTION!

Pre-printed stationery can be used, but the ink must not offset when exposed to the high fuser temperatures used in the printing process.

Continued use of pre-printed stationery may cause the paper feed performance to degrade over time and paper jams may occur. Clean the paper feed rollers as described on [page 81](#).

Envelopes

Envelopes should be handled by the Multi Purpose tray.

CAUTION!

Envelopes should be free from twist, curl or other deformations. They should also be of the rectangular "peel and seal" type, with glue that remains intact when subjected to hot roll pressure fusing used in this type of printer. Window envelopes are not suitable.

Transparencies

Transparencies should be handled by the Multi Purpose tray.

CAUTION!

Transparencies should be of the type designed for use in copiers and laser printers. In particular, avoid office transparencies designed for use by hand with marker pens. These will melt in the fuser and cause damage.

Labels

Labels should be handled by the Multi Purpose tray.

CAUTION!

Labels should also be of the type recommended for use in copiers and laser printers, in which the base carrier page is entirely covered by labels. Other types of label stock may damage the printer due to the labels peeling off during the printing process.

CASSETTE TRAYS

SIZE	DIMENSIONS	WEIGHT (G/M ²)
A6 (Tray 1 only)	105 x 148mm	
A5	148 x 210mm	
B5	182 x 257mm	
Executive	184.2 x 266.7mm	Light 64-82g/m ²
A4	210 x 297mm	Medium light 83- 90g/m ²
B4	250 x 353mm	Medium 91-105g/m ²
A3	420 x 297mm	Heavy 106-128g/m ²
Letter	215.9 x 279.4mm	Ultra heavy1 129-203g/m ²
Legal 13in.	216 x 330mm	Ultra heavy2 204-220g/m ²
Legal 13.5in.	216 x 343mm	(> 176g/m ² - MP Tray only)
Legal 14in.	216 x 356mm	

If you have identical paper stock loaded in another tray (2nd/3rd tray if you have one, or multi purpose tray) you can have the printer automatically switch to the other tray when the current tray runs out of paper. When printing from Windows applications, this function is enabled in the driver settings. When printing from other systems, this function is enabled in the Print Menu.

If fitted, tray 2/3 may be removed and replenished while the machine is being fed from tray 1. Tray 1 cannot be removed while the machine is being fed from tray 2/3, because parts of tray 1 are used to guide paper fed from tray 2. This also applies to tray 2 when paper is being fed from tray 3.

MULTI PURPOSE TRAY

The multi purpose tray can handle the same sizes as the cassette trays but in weights up to 220g/m². For very heavy paper stock use the face up (rear) paper stacker. This ensures that the paper path through the printer is almost straight.

The multi purpose tray can feed paper widths as small as 64mm and lengths up to 1321mm (banner printing).

For paper lengths exceeding 431.8mm use paper stock up to 128g/m² and the face up (rear) paper stacker.

Use the multi purpose tray for printing on envelopes and transparencies. Up to 50 sheets of transparencies or 10 envelopes can be loaded at one time, subject to a maximum stacking depth of 10mm.

Paper or transparencies should be loaded print side up and top edge into the printer. Do not use the duplex (two-sided printing) function.

FACE DOWN STACKER

The face down stacker on the top of the printer can hold up to 250 sheets of 80g/m² standard paper, and can handle paper stocks up to 128g/m². Pages printed in reading order (page 1 first) will be sorted in reading order (last page on top, facing down).

FACE UP STACKER

The face up stacker at the rear of the printer should be opened and the tray extension pulled out when required for use. In this condition paper will exit via this path, regardless of driver settings.

The face up stacker can hold up to 100 sheets of 80g/m² standard paper, and can handle stocks up to 220g/m².

Always use this stacker and the multi purpose feeder for paper stocks heavier than 128g/m².

DUPLEX UNIT

This option provides automatic two-sided printing on the same range of paper sizes as tray 2/3 (i.e. all cassette sizes except A6), using paper stocks from 64-105g/m².

NOTE:

The duplex unit comes as standard with dn & cdt models.

LOADING PAPER

CASSETTE TRAYS

1. Remove the paper tray from the printer.

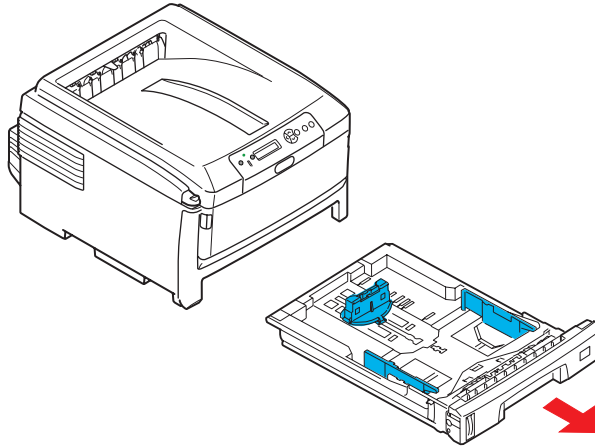

2. Fan the paper to be loaded at the edges (1) and in the middle (2) to ensure that all sheets are properly separated, then tap the edges of the stack on a flat surface to make it flush again (3).

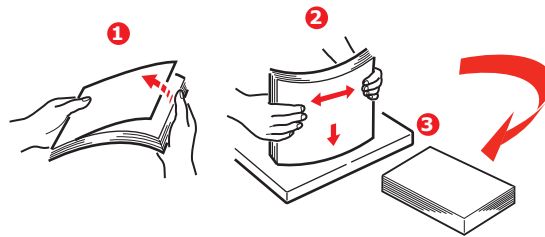

3. Load paper long edge feed (LEF) (letter headed paper - face down and top edge towards the right of the printer) (1) up to mark (a).

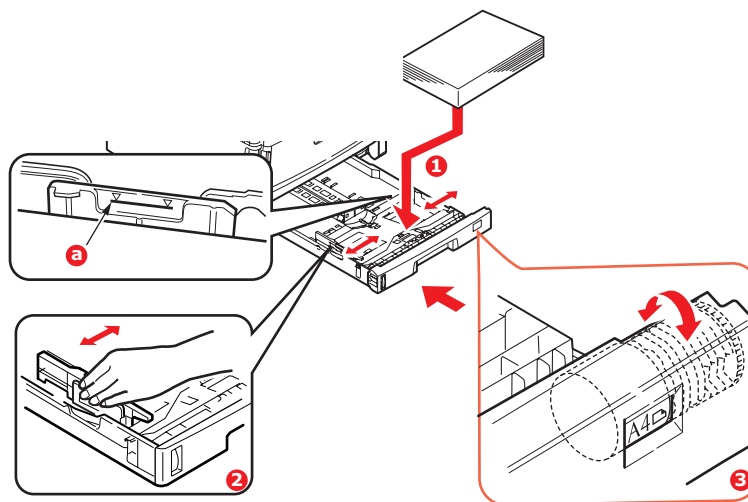

4. Adjust the rear stopper, paper guides (2) and cassette tray roller (3) to the size and orientation of paper being used. For A6 paper, remove and re-install in the A6 position.

CAUTION!

- > **IMPORTANT: Set paper size dial (3) to the size and orientation of paper being used (A4 LEF in the above example).**
- > **C801 and C810: GDI printers use the printer settings defined by the host (PC).**

If the paper is oriented long-edge, the Long Edge Feed (LEF) checkbox must be *enabled* in the printer driver.

If the paper is oriented short-edge, the Long Edge Feed checkbox must be *disabled* in the printer driver.

If the driver setting doesn't match the paper orientation, the printer will display an error message indicating that a mismatch has occurred.

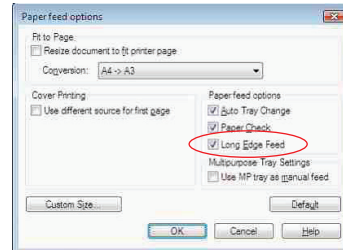

5. Close the paper tray gently.

If you have two trays and you are printing from the 1st (upper) tray, you can pull out the 2nd (lower) tray during printing to reload it. However, if printing from the 2nd (lower) tray, do not pull out the 1st (upper) tray. This will cause a paper jam.

If 3 trays are fitted this applies to trays 1 & 2 if printing from the 3rd (lower) tray.

For face down printing, make sure the face up (rear) stacker (3) is closed (the paper exits from the top of the printer). Stacking capacity is approximately 250 sheets, depending on paper weight.

For face up printing, make sure the face up (rear) stacker (3) is open and the paper support (4) is extended. Paper is stacked in reverse order and tray capacity is approximately 100 sheets, depending on paper weight.

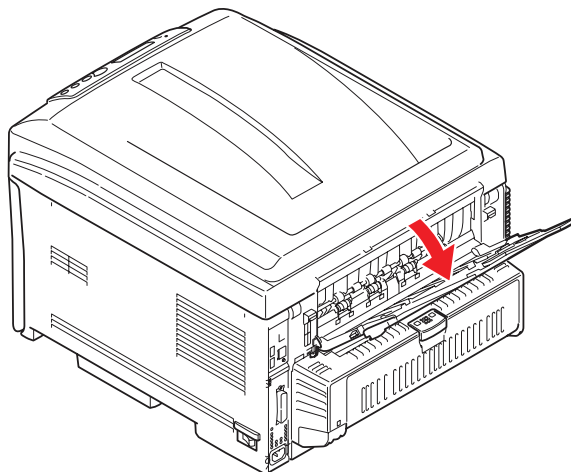

Always use the face up (rear) stacker for heavy paper (card stock etc.).

CAUTION!

Do not open or close the rear paper exit while printing as it may result in a paper jam.

To prevent paper jams:

- > Do not leave space between the paper and the guides and rear stopper.
- > Do not overfill the paper tray. Capacity depends on the type of paper stock.
- > Do not load damaged paper.
- > Do not load paper of different sizes or types at the same time.
- > Do not pull the paper tray out during printing (except as described above for the 2nd tray).

MULTI PURPOSE TRAY

1. Open the multi purpose tray (1).
2. Fold out the paper supports (2).

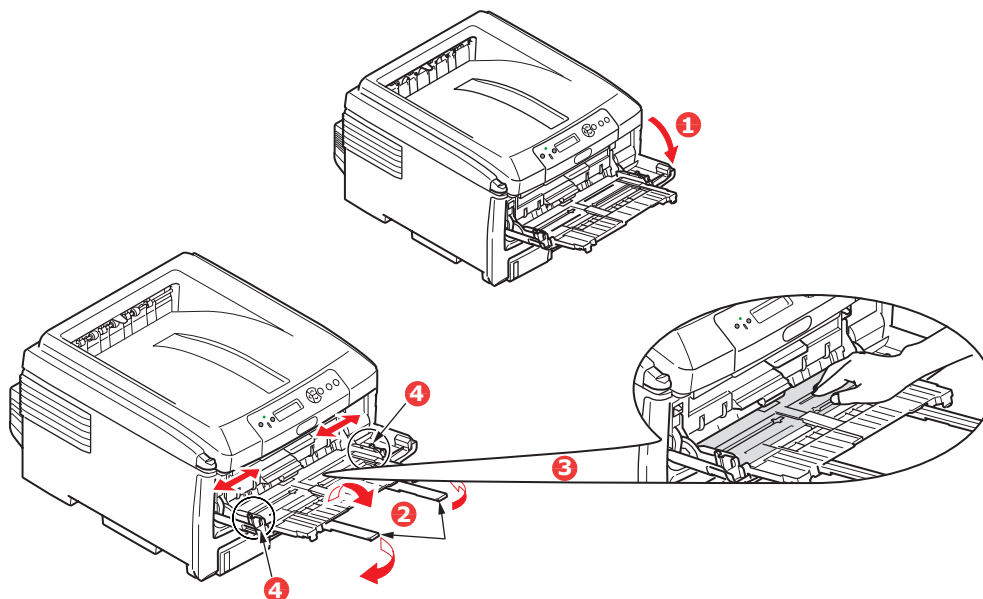

3. Press gently down on the paper platform (3) to ensure it is latched down.
4. Load the paper and adjust the paper guides (4) to the size of paper being used.
 - > For single-sided printing on A4 headed paper load the paper into the multi purpose tray with pre-printed side up and left hand edge (LEF), top edge (SEF) into the printer.
 - > For two-sided (duplex) printing on A4 headed paper load the paper with pre-printed side down and left hand edge (LEF), top edge (SEF) away from the printer. (Optional duplex unit must be installed for this function.)
 - > Envelopes should be loaded face up with top edge to the left and short edge into the printer. Do not select duplex printing on envelopes.
 - > Do not exceed the paper capacity of about 100 sheets or 10 envelopes. Maximum stacking depth is 10mm.

5. Press the tray latch button (5) inwards to release the paper platform, so that the paper is lifted and gripped in place.

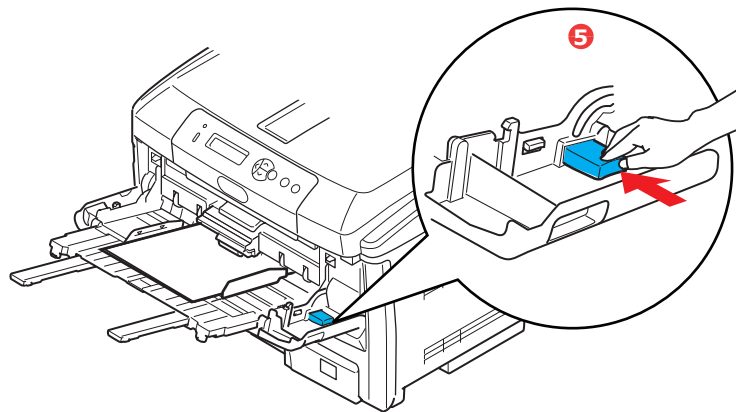

6. Set the correct paper size for the multi purpose tray in the Media Menu (see "Menu Functions").

OPERATION

C801 and C810

For full details of how to use the machine and any optional accessories to print jobs efficiently and effectively, please refer to the following chapters:

- > ["Printing settings in Windows \(C801 and C810 only\)" on page 19](#)
- > ["Printing settings in Mac OS X \(C801 and C810 only\)" on page 24](#)
- > ["Colour printing \(C801 and C810 only\)" on page 33](#)

C821 and C830

For full details of how to use the machine and any optional accessories to print jobs efficiently and effectively, please refer to the Printing Guide and the Barcode Guide.

For full details of how to access and use the printer security features, please refer to the Security Guide.

PRINTING SETTINGS IN WINDOWS (C801 AND C810 ONLY)

Your printer's operator panel menus provide access to many options.

The Windows printer driver also contains settings for many of these items. Where items in the printer driver are the same as those in the operator panel menus, and you print documents from Windows, the settings in the Windows printer driver will override those items in the operator panel menus.

The illustrations in this chapter show Windows XP. Other Windows versions may appear slightly different, but the principles are the same.

PRINTING PREFERENCES IN WINDOWS APPLICATIONS

When you choose to print your document from a Windows application program a print dialogue box appears. This dialogue usually specifies the name of the printer on which you will print your document. Next to the printer name is a **Properties** button.

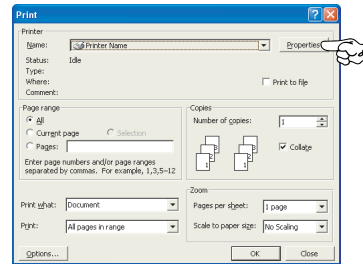

When you click **Properties** a new window opens which contains a short list of the printer settings available in the driver, which you can choose for this document.

The settings available from within your application are only those which you may want to change for specific applications or documents. Settings you change here will usually only last for as long as the particular application program is running.

SETUP TAB

When you click the **Properties** button from your application's Print dialogue, the driver window opens to allow you to specify your printing preferences for the current document.

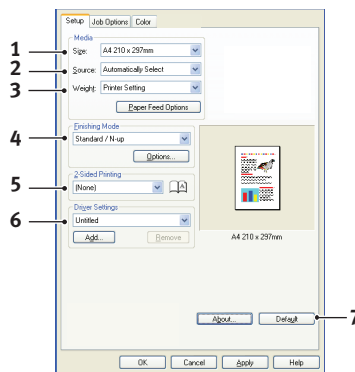

1. Paper size should be the same as the page size of your document (unless you wish to scale the printout to fit another size), and should also be the same as the size of paper you will feed into the printer.
2. You can choose the source of the paper to feed, which may be Tray 1 (the standard paper tray) or the multi purpose feeder. You can also click on the appropriate part of the screen graphic to select your preferred tray.
3. The setting for paper weight should match the type of paper on which you intend to print.
4. A variety of document finishing options can be selected, such as normal one page per sheet, or N-up (where N can be any number up to 16) for printing scaled down pages at more than one page per sheet. Booklet printing prints two pages per sheet on each side of the paper so that when folded they make up a booklet.

Poster printing will print large pages as tiles spread over multiple sheets.

5. For two-sided printing, you can choose to flip the page by the long edge or the short edge.
6. If you have changed some printing preferences before and saved them as a set, you can recall them to avoid having to set them individually each time you need them.
7. A single on-screen button restores the default settings.

JOB OPTIONS TAB

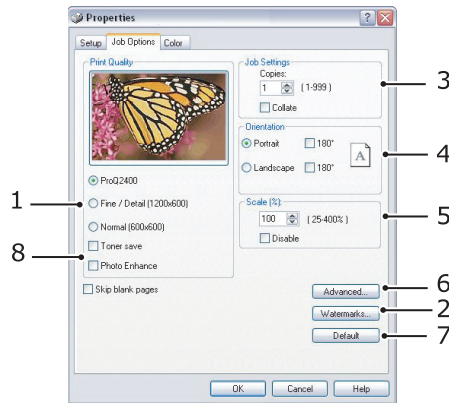

1. The output resolution of the printed page can be set as follows.
 - > The ProQ2400 setting prints at 600 x 600dpi x 2 bit. This option requires the most printer memory and takes the longest to print.
 - > The Fine/Detail setting prints at 1200 x 600dpi and is adequate for all but the most discerning applications.
 - > The Normal setting prints at 600 x 600dpi and is suitable for most draft documents, where print quality is less critical.
2. You can print watermark text behind the main page image. This is useful for marking documents as draft, confidential, etc.
3. You can select up to 999 copies to print consecutively, although you will need to top up the paper tray during such a long print run.
4. Page orientation can be set to either portrait (tall) or landscape (wide).
5. The printed pages can be scaled to fit larger or smaller stationery.
6. Clicking the **Advanced** button gives you access to further settings. For example, you can elect to have black areas printed using 100%K toner (a more matte appearance).
7. A single on-screen button restores the default settings.
8. The quality of photographic images can be improved.

COLOUR TAB

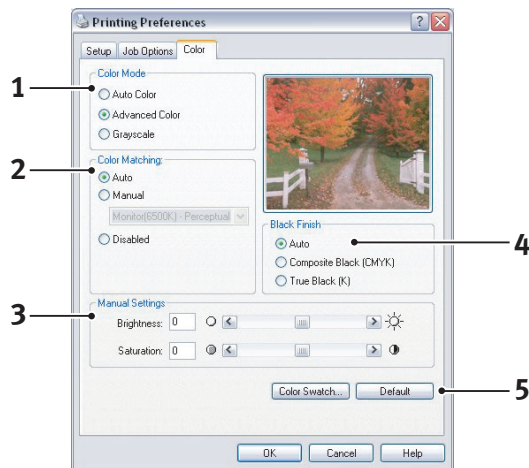

1. Control over the colour output of your printer may be performed automatically, or for advanced control, by manual adjustment. The automatic setting will be appropriate in most cases. The other options in this window only become visible when you select a choice other than **Auto**.
2. You can choose from a range of colour matching options, depending on the image source for your document. For example, a photograph taken on a digital camera might require different colour matching to a business graphic created in a spreadsheet application. Again, for most general purpose use, automatic is the best choice.
3. Printed output may be made lighter or darker, or the colours made more saturated and vibrant as required.
4. Black areas may be printed using cyan, magenta and yellow (composite black), giving a more glossy appearance, or using only black toner (true black), giving a more matte appearance. Choosing the automatic setting allows the driver to make the most appropriate choice depending on image content.
5. A single on-screen button restores the default settings.

SETTING FROM WINDOWS CONTROL PANEL

When you open the driver properties window directly from Windows, rather than from within an application program, a somewhat more extensive range of settings is provided. Changes made here will generally affect all documents you print from Windows applications, and will be remembered from one Windows session to the next.

GENERAL TAB

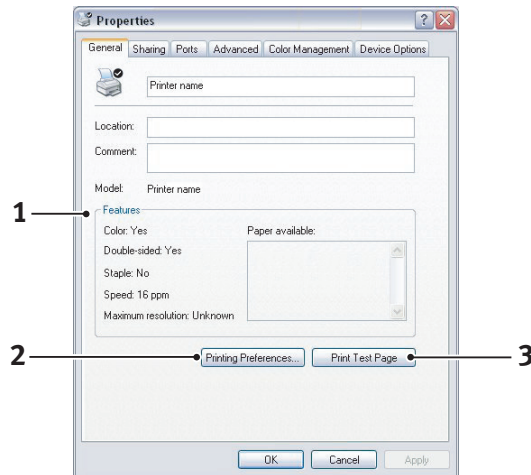

1. This area lists some of the main features of your printer.
2. This button opens the same windows as described earlier for items which can be set from within application programs. Changes you make here, however, will become the new default settings for all Windows applications.
3. This button prints a test page to ensure that your printer is working.

ADVANCED TAB

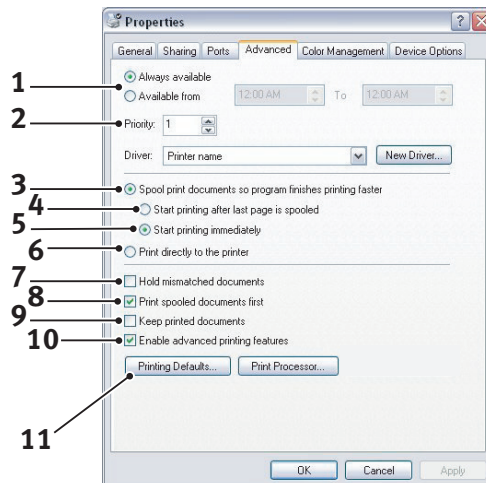

1. You can specify which times of day your printer will be available.
2. Indicates current priority, from 1 (lowest) to 99 (highest). Highest priority documents will print first.
3. Specifies that documents should be spooled (stored in a special print file) before being printed. The document is then printed in the background, allowing your application program to become available more quickly.
4. This specifies that printing should not start until the last page has been spooled. If your application program needs a lot of time for further computation in the middle of

printing, causing the print job to pause for more than a short period, the printer could prematurely assume that the document has finished. Selecting this option would prevent that situation, but printing will be completed a little later, as the start is delayed.

- 5.** This is the opposite choice to the one above. Printing starts as soon as possible after the document begins spooling.
- 6.** This specifies that the document should not be spooled, but printed directly. Your application will not normally be ready for further use until the print job is complete. This requires less disk space on your computer, since there is no spool file.
- 7.** Directs the spooler to check the document setup and match it to the printer setup before sending the document to print. If a mismatch is detected, the document is held in the print queue and does not print until the printer setup is changed and the document restarted from the print queue. Mismatched documents in the queue will not prevent correctly matched documents from printing.
- 8.** Specifies that the spooler should favour documents which have completed spooling when deciding which document to print next, even if completed documents are lower priority than documents which are still spooling. If no documents have completed spooling, the spooler will favour larger spooling documents over shorter ones. Use this option if you want to maximise printer efficiency. When this option is disabled the spooler chooses documents based only on their priority settings.
- 9.** Specifies that the spooler should not delete documents after they are completed. This allows documents to be re submitted to the printer from the spooler instead of printing again from the application program. If you use this option frequently it will require large amounts of disk space on your computer.
- 10.** Specifies whether advanced features, such as booklet printing, page order and pages per sheet, are available, depending on your printer. For normal printing keep this option enabled. If compatibility problems occur you can disable the feature. However, these advanced options may then not be available, even though the hardware might support them.
- 11.** This button provides access to the same setup windows as when printing from applications. Changes made via the Windows Control Panel become the Windows default settings.

PRINTING SETTINGS IN MAC OS X (C801 AND C810 ONLY)

The information in this section is based on Mac OS X Tiger (10.4). Other versions may appear slightly different, but the principles are the same.

SETTING PRINTING OPTIONS

You can choose your printer and select options for how you want your documents to print from the Print dialog box.

To set your printer options:

1. Open the document you want to print.
2. To change the paper size or page orientation, select **File > Page Setup**. For a description of each option, see ["Page setup options" on page 25](#).

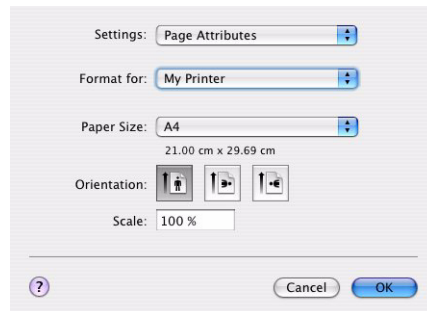

3. Close the Page Setup dialog box.
4. Select **File > Print**.
5. Select your printer from the Printer drop-down menu.
6. To change any printer driver settings, select the required options from the Settings drop-down menu. You can select more options from the Copies & Pages menu. For a description of these options, see ["Print options" on page 26](#).

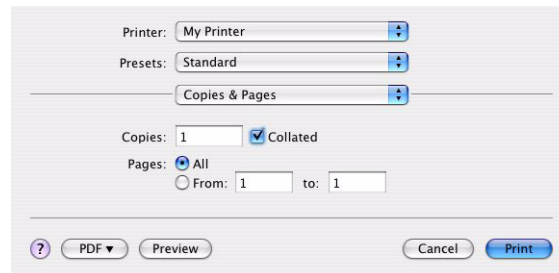

7. Click the **Print** button.

SETTING PRINTING OPTIONS - SAVING DRIVER SETTINGS

You can save a set of printer driver options to use for future documents.

1. Open the document you want to print.
2. To change the paper size or page orientation, select **File > Page Setup**.

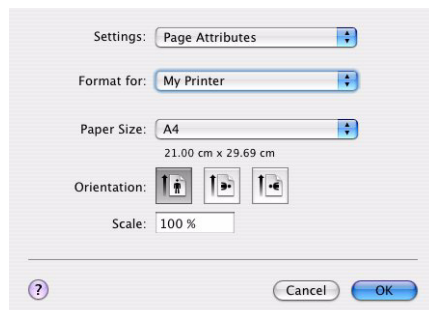

3. Select **Save As Default** from the Settings drop-down menu.
4. Select **File > Print**.
5. To save the current printer driver settings as a preset, select **Save As** from the Preset menu.
6. Enter a name for your preset and click **OK**.

CHANGING THE DEFAULT PRINTER AND PAPER SIZE

The following steps describe how to change your default printer and the paper size options.

1. Select **Apple menu > System Preferences**.
2. Click the **Print & Fax** icon.
3. Select your printer in the **Selected Printer** in Print Dialog drop-down menu.
4. Select your required paper size in the **Default Size** in Page Setup drop-down menu.

PAGE SETUP OPTIONS

This section provides a description of the page setup options available to you.

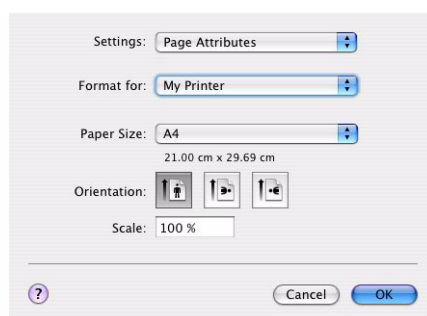

Page Attributes

You can select **Save As Default** to use the current Page Setup settings as a standard for all documents.

Format for

Allows you to select your printer model before changing options such as Paper size and Orientation.

Paper Size

Select a paper size to match your document and the paper loaded in the printer. The paper margin is 4.2mm at all edges. To specify your own paper sizes, select **Manage Custom Sizes...**

Scale

You can scale documents up or down to fit onto different paper sizes. To fit your document on a specific paper size, select **Options** in the **Paper Handling** drop-down menu in the **Print Options** dialog box (see ["Print options" on page 26](#)).

Orientation

You can select a portrait or landscape option. When using landscape, you can rotate the document 180 degrees.

PRINT OPTIONS

COPIES & PAGES

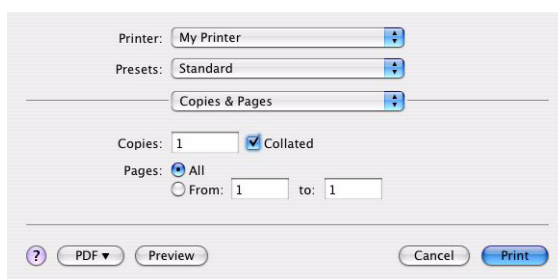

Copies

This option allows you to enter the number of copies to print. If you select **Collate**, all pages of the document will print before the next copy prints.

Pages

You can select whether to print all pages of a document or just a section of it.

LAYOUT

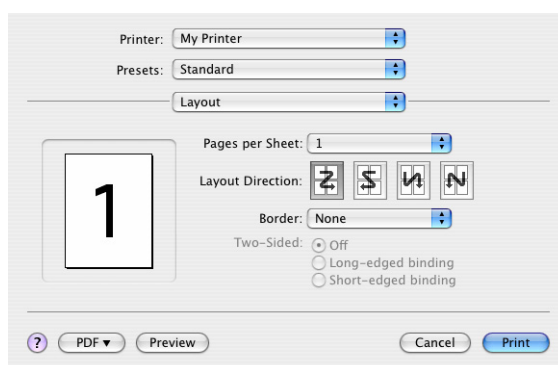

Pages per sheet

You can shrink multiple pages and print them on a single sheet of paper. For example, choosing 4-up will tile four of your document's pages across a single sheet of paper.

You can control the order in which the documents are tiled and also choose to surround each document page with a border.

Two-sided

You cannot use the two sided printing options in this panel. Use the options in the Duplex panel instead. Refer to [“Duplex” on page 28](#).

SCHEDULER

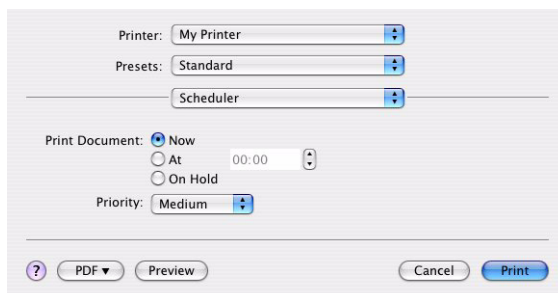

This option lets you choose whether to print your document immediately, or defer printing until later. You can also assign a priority to a print job.

These features are useful if you are printing large documents that take a long time to print.

PAPER HANDLING

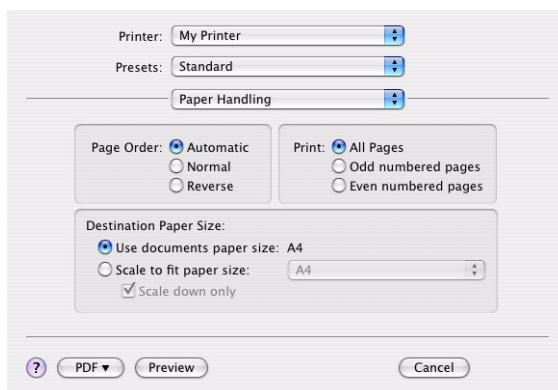

Page order

You can choose to print your document in the normal page order (1,2,3..) or reverse order (..3,2,1).

Print

This option allows you to choose whether to print only odd or even numbered pages. This is useful if you are using manual duplex for which you first print all odd pages, re-insert the paper in the printer and then print all even pages.

Destination paper size

Scale documents to fit on the size of paper in your printer. For example, you can take a document formatted for A3 and print it on A4 paper using an A4 printer.

COLORSYNC

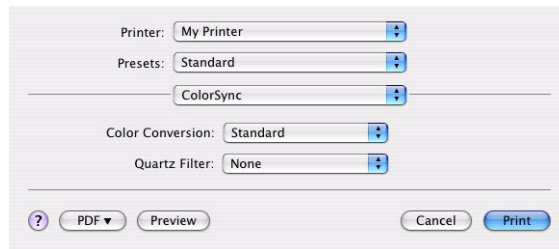

Color conversion

For Color Conversion, Standard is the only option available for your printer model.

Quartz Filter

Choose a Quartz filter if you wish to apply a special effect to your print job, such as Sepia or Blue Tone.

COVER PAGE

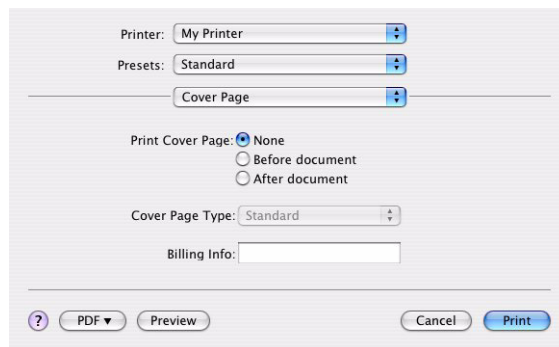

Choosing a cover page may help you to identify your printed document in a large pile of paper. This is useful in a busy office with many people sharing the printer.

DUPLEX

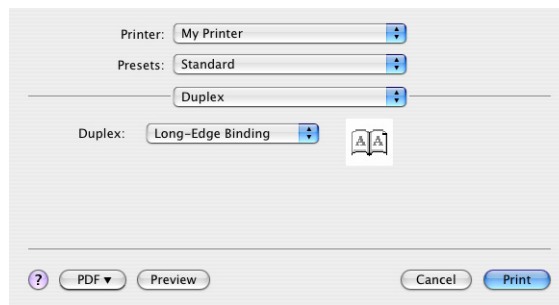

Choosing duplex allows you to print on both sides of the paper, to save paper, weight, bulk and cost.

Long-Edge Binding prints pages that read like a normal book.

Short-Edge Binding prints pages that read like a notepad.

PAPER SOURCE

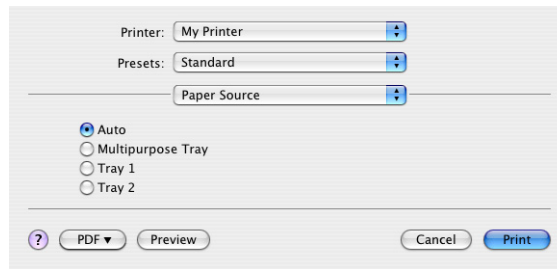

This option allows you to select the paper tray to use for your print job.

PRINT QUALITY

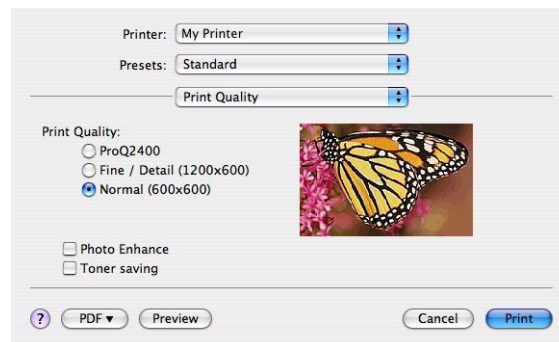

Print quality

Use this option to select the print resolution. The ProQ2400 setting produces the best graphic images, but these images can take longer to print.

Photo Enhance

Use **Photo Enhance** to significantly improve quality when printing images. The printer driver analyses any photographic images and processes them to improve the overall appearance. This setting cannot be used together with the "ProQ2400" print quality setting.

Toner Saving

Toner saving uses less toner when printing your document. This is best suited to draft text documents as it lightens the print significantly.

COLOUR

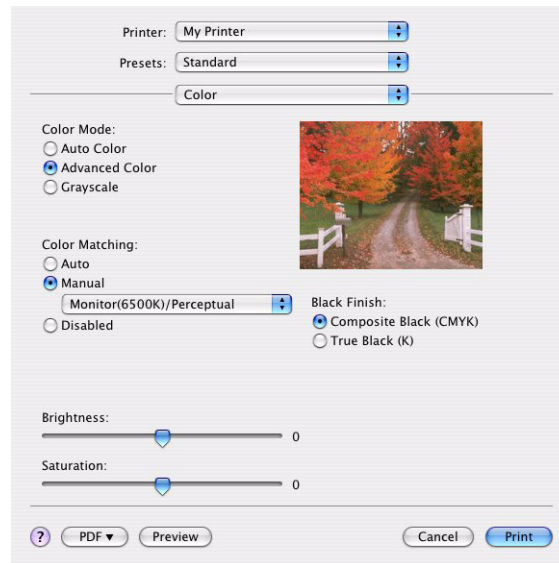

Colour mode

COLOUR MODE	DESCRIPTION
Advanced Colour	The driver selects the most appropriate color settings.
Manual	Allows you to manually adjust colour and black and white settings or select.
Grayscale	Convert all colours to shades of grey.

Color matching

COLOUR	DESCRIPTION
Monitor (6500K) Perceptual	Optimised for printing photos. Colours are printed with emphasis on saturation.
Monitor (6500K) Vivid	Optimised for printing photos, but with even more saturated colours.
Monitor (9300K)	Optimised for printing graphics from applications such as Microsoft Office. Colours are printed with emphasis on Lightness.
Digital Camera	Results will vary depending on the subject and conditions the image was taken.
sRGB	The printer reproduces the sRGB colour space. This might be useful if colour matching from an sRGB input device such as a scanner or digital camera.

Black Finish

Use this option to control the way black is printed in colour documents. Select **Composite Black (CMYK)** to use all 4 toner colours to represent black. This option is recommended for color photos. Select **True Black (K)** to use 100% black toner to represent black. This option is recommended for text and business graphics.

Brightness / Saturation

This option allows you to increase brightness for a lighter print. Modify saturation to change the strength (or purity) of a colour.

If the printed colours are too strong, reduce saturation and increase brightness. As a general rule, reduce saturation by the same amount as you increase brightness. For example, if you reduce saturation by 10, increase brightness by 10 to compensate.

PRINTER SETUP OPTIONS

PRINTER OPTIONS

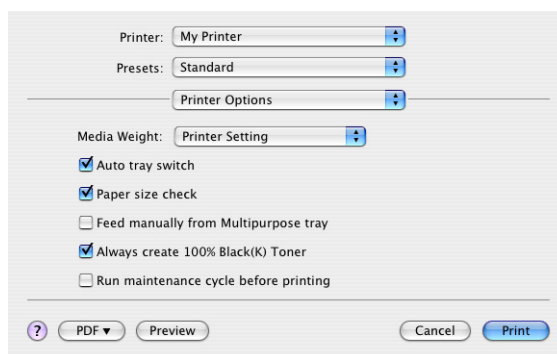

Media weight

Select the thickness or type of paper in the printer. It is important to set this correctly as it affects the temperature at which the toner is fused to the paper. For example, if you are printing on normal A4 paper, do not select Labels or Transparency as this may cause toner smearing and paper jams.

Auto tray switch

If the printer runs out of paper in the current tray, Auto Tray Switch automatically changes to a tray that has the same type of paper and continues printing.

Paper size check

Select Paper Size check if you want the printer to warn you when the document paper size is different from the paper in the printer.

A warning message is displayed and printing continues when you load the correct paper in the paper tray and press **ONLINE**. When this option is deselected, the printer uses the paper loaded in the selected tray regardless of the document size.

Feed manually from Multipurpose Tray

Select this option if you want the printer to wait until you press the **ONLINE** button when feeding from the Multipurpose Tray. This can be useful if printing on envelopes.

Always create 100% black (K) toner

Select this option if you want the printer to always use only black (K) toner when printing pure black (RGB = 0,0,0). This is effective even when Composite Black (CMYK) is selected in the colour options.

Run maintenance cycle before printing

Depending on printing habits and usage patterns, running the maintenance cycle before printing may ensure the best possible print quality. This feature uses the printer's image drums and transfer belt. The life of these printer consumables may be shortened if the printer runs a maintenance cycle frequently.

PRINT CONTROL



If you are using the Windows Print Control Server software to manage printers, enter your assigned user name and ID. This information is sent to the printer with your print job and is recorded by the printer.

SUMMARY

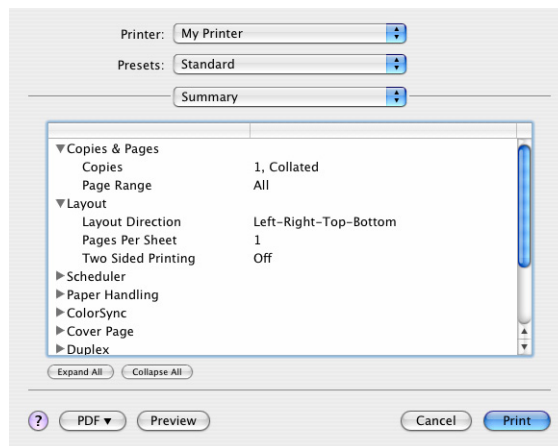

This option displays a summary of all selected print options for the current job.

COLOUR PRINTING (C801 AND C810 ONLY)

The printer drivers supplied with your machine provide several controls for changing the colour output. For general use the automatic settings will suffice, providing reasonable default settings that will produce good results for most documents.

Many applications have their own colour settings, and these may override the settings in the printer driver. Please refer to the documentation for your software application for details on how that particular program's colour management functions.

FACTORS THAT AFFECT THE APPEARANCE OF PRINTS

If you wish to manually adjust the colour settings in your printer driver, please be aware that colour reproduction is a complex topic, and there are many factors to take into consideration. Some of the most important factors are listed below.

Differences between the range of colours a monitor or printer can reproduce

- > Neither a printer nor a monitor is capable of reproducing the full range of colours visible to the human eye. Each device is restricted to a certain range of colours. In addition to this, a printer cannot reproduce all of the colours displayed on a monitor, and vice versa.
- > Both devices use very different technologies to represent colour. A monitor uses Red, Green and Blue (RGB) phosphors (or LCDs), a printer uses Cyan, Magenta, Yellow and Black (CMYK) toner or ink.
- > A monitor can display very vivid colours such as intense reds and blues and these cannot be easily produced on any printer using toner or ink. Similarly, there are certain colours, (some yellows for example), that can be printed, but cannot be displayed accurately on a monitor. This disparity between monitors and printers is often the main reason that printed colours do not match the colours displayed on screen.

Viewing conditions

A print can look very different under different lighting conditions. For example, the colours in a print may look different when viewed standing next to a sunlit window, compared to how they look under standard office fluorescent lighting.

Printer driver colour settings

The driver settings for Manual colour can change the appearance of a print. There are several options available to help match the printed colours with those displayed on screen.

Monitor settings

The brightness and contrast controls on your monitor can change how your document looks on-screen. Additionally, your monitor's colour temperature influences how "warm" or "cool" the colours look.

There are several settings found on a typical monitor:

- > 5000k Warmest; yellowish lighting, typically used in graphic art environments.
 - > 6500k Cooler; approximates daylight conditions.
 - > 9300k Cool; the default setting for many monitors and television sets.
- (k = degrees Kelvin, a measurement of temperature.)

How your software application displays colour

Some graphics applications such as Corel Draw or Adobe Photoshop may display colour differently from "Office" applications such as Microsoft Word. Please see your application's on-line help or user manual for more information.

Paper type

The type of paper used can also significantly affect the printed colour. For example, a printout on recycled paper can look duller than one on specially formulated glossy paper.

TIPS FOR PRINTING IN COLOUR

The following guidelines may help you to achieve good colour output from your printer.

PRINTING PHOTOGRAPHIC IMAGES

Use the Monitor (6500k) Perceptual setting.

If the colours look too dull, try the Monitor (6500k) Vivid or Digital Camera settings.

PRINTING FROM MICROSOFT OFFICE APPLICATIONS

Use the Monitor (9300k) setting. This may help if you are having problems with specific colours from applications such as Microsoft Excel or Microsoft Powerpoint.

PRINTING SPECIFIC COLOURS (E.G. A COMPANY LOGO)

There are 2 utilities on your DVD-ROM that can help match specific colours:

- > Colour Correct Utility
- > Colour Swatch Utility

ADJUSTING THE BRIGHTNESS OR INTENSITY OF A PRINT

If the print is too light/dark, you can use the Brightness control to adjust it.

If the colours are too intense/not intense enough, use the Saturation control.

ACCESSING THE COLOUR MATCHING OPTIONS

The colour matching options in the printer driver can be used to help match your printed colours to the ones displayed on your monitor or from some other source, such as a digital camera.

To open colour matching options from the Windows Control Panel:

1. Open the **Printers** window (called "Printers and Faxes" in Windows XP).
2. Right-click the printer name and choose **Properties**.
3. Click the **Printing Preferences** button (1).

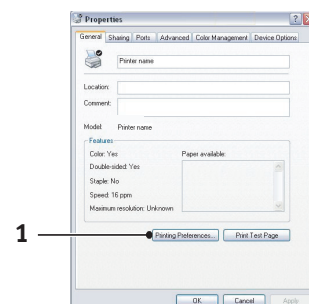

To open colour matching options from within a Windows application:

1. Choose **File > Print...** from the application's menu bar.
2. Click the **Properties** button next to the printer name.

SETTING THE COLOUR MATCHING OPTIONS

1. On the **Colour** tab select **Advanced Colour** (1) for colour matching.

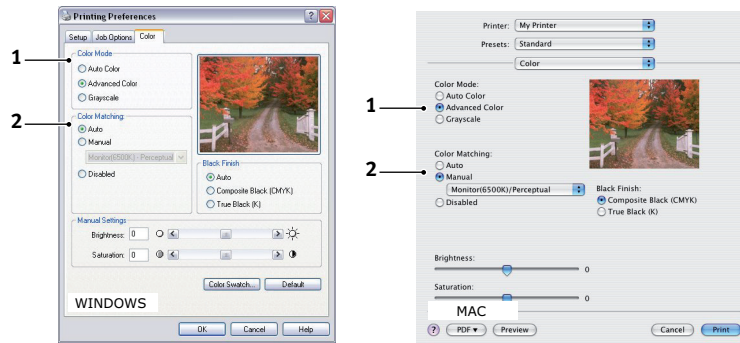

2. Choose the **Manual** colour setting (2) and select from the following options:

- (a) Monitor (6500k) Perceptual

Optimised for printing photographs. Colours are printed with emphasis on saturation.

- (b) Monitor (6500k) Vivid

Optimised for printing photographs, but with even more saturated colours than the Monitor (6500k) Perceptual setting.

- (c) Monitor (9300k)

Optimised for printing graphics from applications such as Microsoft Office. Colours are printed with emphasis on Lightness.

- (d) Digital Camera

Optimised for printing photographs taken with a digital camera.

Your results will vary depending on the subject and the conditions under which the photograph was taken.

- (e) sRGB

The printer will try to reproduce the sRGB colour space. This may be useful if colour matching from an sRGB input device such as a scanner or digital camera.

USING THE COLOUR SWATCH FEATURE

To use the Colour Swatch feature, you must install the Colour Swatch Utility. This is supplied on the DVD-ROM that you received with your printer.

The Colour Swatch function prints charts which contain a range of sample colours. Note that this is not the full range of colours that the printer can produce. Listed on each sample colour are the corresponding RGB (Red, Green, Blue) values. This can be used to pick specific colours in applications that allow you to choose your own RGB values. Simply click the **Colour Swatch** button (1) and choose from the options available.

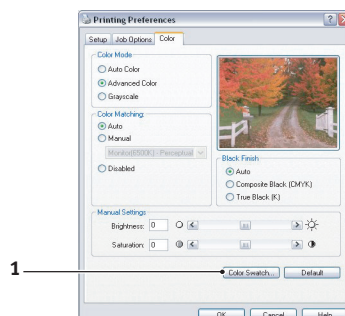

An example of using the Colour Swatch function:

You wish to print a logo in a particular shade of red. The steps you would follow are:

- 1.** Print a colour swatch, then select the shade of red that best suits your needs.
- 2.** Take a note of the RGB value for the particular shade that you liked.
- 3.** Using your program's colour picker, enter these same RGB values, and change the logo to that colour.

The RGB colour displayed on your monitor may not necessarily match what was printed on the colour swatch. If this is the case, it is probably due to the difference between how your monitor and printer reproduce colour. Here, it is unimportant since your primary objective is to print the required colour.

USING THE COLOUR CORRECT UTILITY

The Oki Colour Correct Utility is provided on your DVD-ROM.

The Colour Correct utility has the following features:

- > Office palette colours can be individually adjusted. This is useful if you want to change how a specific colour is printed.
- > Colours can be adjusted by changing Hue, Saturation and Gamma. This is useful if you wish to change the overall colour output.

Once these colour adjustments have been made, the new settings can be selected from the printer driver Colour tab.

To select adjustments made with the Colour Correct Utility:

- 1.** From your application program, click **File** and point to **Print**.
- 2.** Click **Properties**. This displays the printer driver options.
- 3.** Click the **Colour** tab.
- 4.** Click **Advanced Colour**.
- 5.** Click **User Defined**.

Select the colour adjustment you made with the Colour Correct Utility.

MENU FUNCTIONS - C801 AND C810

This section lists the menus accessed via the controls on the printer’s operator panel and displayed in the LCD window.

OPERATOR PANEL

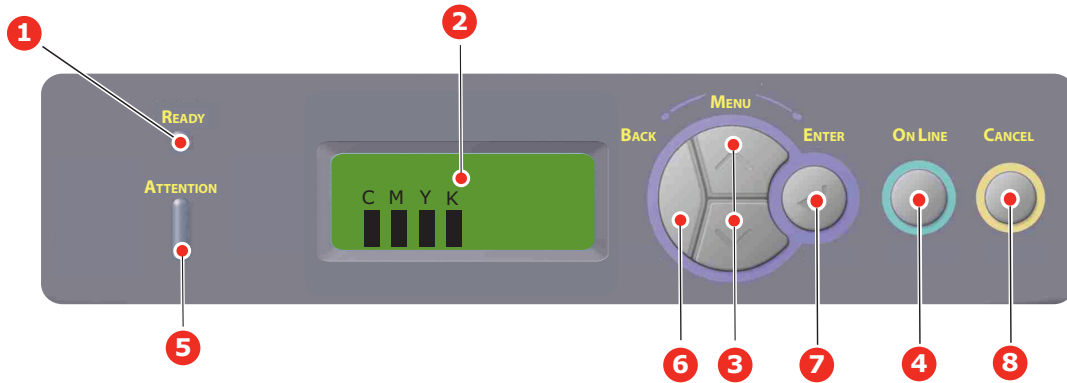

1. Ready LED	ON: Ready to receive data. Blinking: Processing data. OFF: Offline.	2. Display	Displays the printer status and any error messages.
3. Menu Button	Enters the Menu mode. In Menu mode, forwards or reverses the menu item displayed. Press for 2 secs. or longer to fast forward or reverse.	4. On Line Button	Switches between ONLINE and OFFLINE . Exits the menu and goes ONLINE when pressed in the Menu mode. Scrolls the HELP screen. Forces printing on the paper currently loaded when pressed with "WRONG PAPER" or "WRONG PAPER SIZE" displayed.
5. Attention LED	ON: A warning occurs. Printing is possible. Blinking: An error occurs. Printing not possible. OFF: Normal condition.	6. Back Button	Returns to the previous higher level menu item.
7. Enter Button	In the ONLINE or OFFLINE mode: enters the Menu mode. In the Menu mode: determines the setting selected.	8. Cancel Button	Deletes the data being printed or received when pressed for two seconds or longer. Deletes the data when pressed for two seconds or longer with WRONG PAPER SIZE, RUN OUT OF PAPER, TRAY 1 IS OPEN, or TRAY 1 IS NOT FOUND is displayed.

HOW TO CHANGE THE SETTINGS - USER

It should be noted that many of these settings can be, and often are, overridden by settings in the Windows printer drivers. However, several of the driver settings can be left at "Printer Setting", which will then default to the settings entered in these printer menus.

Where applicable, factory default settings are shown in bold type in the following tables.

In the normal operating condition, known as "standby," the printer’s LCD window will show "ONLINE." In this condition, to enter the menu system, press the +/- buttons on the operator panel to move up and down through the list of menus until the menu you wish to view is displayed. Then proceed as follows:

1. Press **ENTER** to enter the menu.

2. Use the up or down **Menu** buttons to move up and down through the items in the menu. When the item you want to change is displayed, press **Enter** to edit that item. An asterisk (*) appears next to the setting currently in effect.
3. Use the up or down **Menu** buttons to move up and down through the available settings for this item, and press **Enter** when the setting you want is displayed. An asterisk (*) will appear next to the setting, indicating that this setting is now in effect.
4. Press **BACK** to move back to the list of menu items.
5. Do one of the following:
 - > Press **BACK** again to move up to the list of menus;
 - or...
 - > Press **ON LINE** to exit from the menu system and return to standby.

NOTE:

*When you have changed any settings in the USB MENU, turn the printer **OFF**, then **ON** again.*

HOW TO CHANGE THE SETTINGS - ADMINISTRATOR

You can set whether to **ENABLE** or **DISABLE** each category in the user menu.

Disabled categories are not displayed in the User's menu.

Only a system administrator can change these settings.

1. Turn **OFF** the printer.
2. Turn **ON** the printer while pressing the **Enter** button.
When the **Admin Menu** appears, take your finger off the button.
3. Press the **Enter** button.
4. When **Enter Password** appears, press the up or down **Menu** button several times to display the 1st line of the password and then press the Enter button.
Enter your 4- to 9-digit password.
(The default password is "aaaaaa").
5. Press the **Enter** button.
6. Press the up or down **Menu** button until the "category" you want to change is displayed.
7. When it is, press the **Enter** button.
8. Press the up or down **Menu** button until the "item" you want to change is displayed.
9. When it is, press the **Enter** button.
10. Initialization of the flash memory prompts with the message ARE YOU SURE?. Confirm whether the change may be executed or not.
11. To execute it, press the up or down **Menu** button to display **YES** and then press the **Enter** button. The printer automatically reboots.
12. When PLEASE POW OFF/SHUTDOWN COMP is displayed, turn the printer **OFF/ON**
13. Press the up or down **MENU** button until the setting you want is displayed.
14. Press the **Enter** button to enter [*] on the right side of the setting selected.
15. Press the **On Line** button to switch the printer online.

MENUS

INFORMATION MENU

This menu provides a quick method of listing various items stored within the printer.

ITEM	ACTION	EXPLANATION
PRINT MENU MAP	EXECUTE	Prints complete menu listing with current settings shown.
NETWORK	EXECUTE	Prints Network configuration information.
DEMO1	EXECUTE	Prints demonstration page containing graphics and text in colour and monochrome.
USAGE REPORT	EXECUTE	Prints a report of total impressions and supply replacements.

SHUTDOWN MENU

ITEM	ACTION	EXPLANATION
SHUTDOWN START	EXECUTE	Starts the power off sequence (this protects the filing system).

PRINT MENU

This menu provides adjustment of various print job related functions.

ITEM	SETTINGS	EXPLANATION
COPIES	1-999	Enter the number of copies of a document to be printed from 1 to 999.
PAPER FEED	TRAY1 TRAY2 MP TRAY	Selects the default tray for paper feed, Tray 1 (upper), Tray 2 (lower, if installed) or MP Tray (multi purpose tray).
AUTO TRAY SWITCH	ON OFF	If two trays contain identical paper, the printer can switch to an alternative source when the current tray runs out in the middle of a print job.
TRAY SEQUENCE	DOWN UP PAPER FEED TRAY	Determines tray sequence order when automatically switching.
MP TRAY USAGE	DO NOT USE WHEN MISMATCH	If a document to be printed demands a paper size not installed in the selected tray, the printer can automatically feed from the multi purpose tray instead. If this function is not enabled, the printer will stop and request the correct size of paper to be loaded.
MEDIA CHECK	ENABLE DISABLE	Determines whether the printer check the size of paper loaded matches that required for the document sent to print.

ITEM	SETTINGS	EXPLANATION
MONO-PRINT SPEED	AUTO SPEED	If the first page of a print job is black and white, the printer runs at 32ppm (pages per minute). When a colour page is detected the printer slows down to 30ppm (C810) or 26ppm (C801) for the rest of that job.
	MONO 32PPM	This setting operates in the same way as AUTO SPEED, except that the printer runs at 32ppm until a colour page is detected. To achieve this speed the printer requires an additional time to warm up and cool down when switching to 30ppm (C810) or 26ppm (C801) for colour pages. This setting is therefore most appropriate when the majority of print jobs are entirely black and white.
	COLOR SPEED	The printer runs at 30ppm (C810) or 26ppm (C801) for all print jobs. This setting is most appropriate when the majority of print jobs are in colour.
	MIXED SPEED	The printer runs at 26 ppm (C810) or 22ppm (C801) for colour pages and 30 ppm (C810) or 26ppm (C801) for mono pages.

MEDIA MENU

This menu provides adjustment to suit a wide range of print media.

ITEM	SETTINGS	EXPLANATION
TRAY1 PAPERSIZE	CASSETTE SIZE CUSTOM	Selects the size of paper loaded in Tray 1 (upper tray if both trays installed). For CUSTOM setting see X-DIMENSION and Y-DIMENSION later in this table.
TRAY1 MEDIATYPE	PLAIN LETTERHEAD BOND RECYCLED CARD STOCK GLOSSY ROUGH	Selects the type of media loaded in this tray. This will help the printer to adjust its internal operating parameters, such as engine speed and fusing temperature, to better accommodate the media to be fed. For example, letterhead may benefit from a slightly lower fusing temperature to ensure that its ink does not offset.
TRAY1 MEDIAWEIGHT	LIGHT MEDIUM LIGHT MEDIUM HEAVY	Adjusts the printer for the weight of paper stock loaded in this tray.
TRAY2 PAPERSIZE	CASSETTE SIZE CUSTOM	Selects the size of paper loaded in Tray 2 (lower) if installed. For CUSTOM setting see X-DIMENSION and Y-DIMENSION in this table.
TRAY2 MEDIATYPE	PLAIN LETTERHEAD BOND RECYCLED CARD STOCK GLOSSY ROUGH	Selects the type of media loaded in this tray (if installed). (see notes above for tray 1).
TRAY2 MEDIAWEIGHT	LIGHT MEDIUM LIGHT MEDIUM HEAVY	Adjusts the printer for the weight of paper stock loaded in this tray (if installed).
TRAY3 PAPERSIZE	CASSETTE SIZE CUSTOM	Selects the size of paper loaded in Tray 3 (lower) if installed.

ITEM	SETTINGS	EXPLANATION
TRAY3 MEDIATYPE	PLAIN LETTERHEAD TRANSPARENCY BOND RECYCLED CARD STOCK GLOSSY ROUGH	Selects the type of media loaded in this tray (if installed). (see notes above for tray 1).
TRAY3 MEDIAWEIGHT	LIGHT MEDIUM LIGHT MEDIUM HEAVY-	Adjusts the printer for the weight of paper stock loaded in this tray (if installed).
MPT PAPERSIZE	A3 A4 SEF A4 LEF A5 SEF A6 B4 B5 SEF B5 LEF LEGAL 14 LEGAL 13.5 LEGAL 13 TABLOID LETTER SEF LETTER LEF EXECUTIVE CUSTOM COM-10 ENVELOPE DL ENVELOPE C5 ENVELOPE C4 ENVELOPE	Selects the size of paper to be fed from the multi purpose tray. For CUSTOM setting see X-DIMENSION and Y-DIMENSION later in this table.
MPT MEDIATYPE	PLAIN LETTERHEAD TRANSPARENCY LABELS CARD STOCK GLOSSY BOND RECYCLED ROUGH	Selects the type of media to be fed from the multi purpose tray so that the printer can adjust its internal parameters to better accommodate the selected type of media.
MPT MEDIAWEIGHT	LIGHT MEDIUM LIGHT MEDIUM HEAVY ULTRA HEAVY1 ULTRA HEAVY2	Selects the media weight to be fed from the multi purpose tray.
UNIT OF MEASURE	MILLIMETRE INCH	Selects the unit of measure for the next two items.

COLOUR MENU

The printer automatically adjusts colour balance and density at appropriate intervals, optimising the printed output for bright white paper viewed in natural daylight conditions. The items on this menu provide a means of changing the default settings for special or particularly difficult print jobs. Settings revert to their default values when the next print job is complete.

ITEM	SETTINGS	EXPLANATION
DENSITY CONTROL	AUTO MANUAL	Selecting this will permit automatic adjustment of the colour density.
ADJUST DENSITY	EXECUTE	Image density will be automatically adjusted at power on, when a new image drum or toner cartridge is installed, and at intervals of 100, 300 and 500 drum counts. If a 500 drum count interval occurs during a print job it will occur at the end of that job, and will take up to 55 seconds.
AJST REGISTRATION	EXECUTE	Performs automatic colour registration adjustment. Normally this is done on power on and when the top cover is opened and then closed. This process accurately aligns the cyan, magenta and yellow images to the black image.
C REG FINE ADJ M REG FINE ADJ Y REG FINE ADJ	-3~ 0 ~+3 -3~ 0 ~+3 -3~ 0 ~+3	Performs fine adjustment of image timing in relation to the black image component.

SYSTEM CONFIGURATION MENU

This menu adjusts general printer settings to suit the way you prefer to work.

ITEMS	SETTINGS	EXPLANATION
POW SAVE DELAY	1 3 5 15 30 60 240	Adjusts the idling time before the printer automatically switches into power saving mode. In this mode power consumption is reduced to a low level required to just keep the printer operating and ready to receive data. When a job is sent the printer will require a warm-up time of up to 1 minute before printing can begin.
CLRABLE WARNING	ONLINE JOB	When ONLINE, non-critical warnings, such as requests for a different paper size, can be cleared by pressing the ON LINE button. When set to JOB, they are cleared when the print job resumes.
MANUAL TIMEOUT	OFF 30 60	Specifies how many seconds the printer will wait for paper to be fed before cancelling the job.
WAIT TIMEOUT	OFF~ 90 ~300	Specifies how many seconds the printer will wait when received data pauses before forcing a page eject. In PostScript Emulation mode the job will be cancelled if timeout occurs.
TONER LOW CONTINUE	CONTINUE STOP	Specifies whether the printer should continue printing even after a low toner condition is detected.
JAM RECOVERY	ON OFF	Specifies whether the printer should perform jam recovery after a paper jam has occurred. If ON, the printer will attempt to print again any pages lost due to a paper jam once the jam has been cleared.
ERROR REPORT	ON OFF	Sets whether an error report is printed when an internal fault occurs.

USB MENU

This menu controls the operation of the printer's USB data interface.

ITEM	SETTINGS	EXPLANATION
SOFT RESET	ENABLE / DISABLE	Enables or disables the SOFT RESET command.
SPEED	12 / 480 Mps	Selects the interface speed.
SERIAL NUMBER	ENABLE / DISABLE	Specifies whether to ENABLE or DISABLE a USB serial number. The USB serial number is used to identify the USB device connected to your PC.

NOTE:
When you have changed any settings in the USB MENU, turn the printer OFF, then ON again.

NETWORK MENU

This menu controls the operation of the printer's 10Base-T/100Base-TX network interface.

ITEM	SETTINGS	EXPLANATION
TCP/IP	ENABLE / DISABLE	Enables or disables this network protocol.
NETBEUI	ENABLE / DISABLE	Enables or disables this network protocol.
IP ADDRESS SET	AUTO / MANUAL	Specifies whether IP address allocation is automatic (DHCP) or manually assigned.
IP ADDRESS	xxx.xxx.xxx.xxx	Current assigned IP address. To change, press ENTER and use up or down buttons to increment 1st octet, then press ENTER again to move on to next octet. When 4th octet has been set, press ENTER again to register new address.
SUBNET MASK	xxx.xxx.xxx.xxx	Current assigned subnet mask. To change, proceed as above.
GATEWAY ADDRESS	xxx.xxx.xxx.xxx	Current assigned gateway address. To change, proceed as above.
WEB	ENABLE / DISABLE	Enables or disables Web config. facility.
TELNET	ENABLE / DISABLE	Enables or disables Telnet config. facility.
FTP	ENABLE / DISABLE	Enables or disables communication via FTP.
SNMP	ENABLE / DISABLE	Enables or disables SNMP protocol.
NETWORK SCALE	NORMAL / SMALL	Selects network size.
HUB LINK SETTING	AUTO NEGOTIATE 100BASE-TX FULL 100BASE-TX HALF 10BASE-T FULL 10BASE-T HALF	Sets full or half duplex for communication via a network hub.

ITEM	SETTINGS	EXPLANATION
FACTORY DEFAULTS ENABLE	EXECUTE	Reloads the settings present when the unit was setup by the manufacturer.

MAINTENANCE MENU

This menu provides access to various printer maintenance functions.

ITEM	SETTINGS	EXPLANATION
MENU RESET	EXECUTE	Resets menus to default settings.
SAVE MENU	EXECUTE	Saves the current menu settings. The last menu executed is saved and the menu previously saved is overwritten and erased. When you press the ENTER button, the following confirmation message is displayed. "DO YOU WANT TO EXECUTE THIS FUNCTION?" YES/NO If you select NO, the display returns to the previous menu. If you select YES, the current menu settings are stored and the menu is exited.
POWER SAVE	ENABLE / DISABLE	Enables or disables automatic power save mode. Delay before entering this mode is set in the SYSTEM CONFIGURATION menu.
PAPER BLACK SET	-2~ 0 ~+2	Used for small adjustment when you experience faded print or light specks / streaking in monochrome printing on white paper. Select a higher value to reduce fading, or a lower value to reduce specks or streaking in high density print areas.
PAPER COLOR SET	-2~ 0 ~+2	As above, but for colour printing.
TRNSPR BLACK SET	-2~ 0 ~+2	As above but for mono printing on transparencies.
TRNSPR COLOR SET	-2~ 0 ~+2	As above but for colour printing on transparencies.
SMR SETTING	-3~ 0 ~+3	Compensates for print variations caused by differences in temperature, humidity, and printing density/frequency. Change the value when the image quality is uneven.
BG SETTING	-3~ 0 ~+3	Compensates for print variations caused by differences in temperature, humidity and printing density/frequency. Change the value when the background density is high.

USAGE MENU

This menu is for information only, and provides an indication of total usage of the printer and the expected life left in its consumable items. This is particularly useful if you do not have a full set of replacement consumables to hand and you need to know how soon you will need them.

ITEM	DISPLAY	EXPLANATION
TRAY1 COUNT	nnnnnn	The total number of pages fed from tray 1.
TRAY2 COUNT	nnnnnn	The total number of pages fed from tray 2 (if fitted).
TRAY3 COUNT	nnnnnn	The total number of pages fed from tray 3 (if fitted).
MPT COUNT	nnnnnn	The total number of pages fed from the multi purpose tray.

ITEM	DISPLAY	EXPLANATION
K DRUM LIFE C DRUM LIFE M DRUM LIFE Y DRUM LIFE	REMAINING nnnnnn	Percentage of life remaining in these consumable items.
BELT LIFE	REMAINING nnnnnn	Percentage of belt life remaining.
FUSER LIFE	REMAINING nnnnnn	Percentage of fuser life remaining.
K TONER C TONER M TONER Y TONER	REMAINING nnnnnn	Cartridge size and current toner level.

ADMINISTRATOR (BOOT) MENU

This menu should only be changed by the System Administrators. In order to gain access to this menu, follow the instructions in ["How to change the settings - Administrator" on page 38](#).

This menu is in **ENGLISH** only (default settings in bold type).

ITEM	SUB-MENU	SETTINGS	EXPLANATION
Enter Password		xxxxxxxxxxxx	Enter a password to gain entry to the Admin menu. Password should be from 6 to 12 digits of alpha/numeric characters (or mix) The default value is "aaaaaa" The printer will restart after the Boot Menu.
	OP Menu		
	ALL CATEGORY	ENABLE/ DISABLE	Enables/Disables all categories in the USERS MENU. If DISABLE is selected, only the PRINT JOB MENU will appear.
	INFORMATION MENU	ENABLE/ DISABLE	Enables/disables the information menu. If DISABLE is selected, the information menu will not appear.
	SHUTDOWN MENU	ENABLE/ DISABLE	Enables/disables the shutdown menu. If DISABLE is selected, this menu will not appear.
	PRINT MENU	ENABLE/ DISABLE	Enables/disables the print menu. If DISABLE is selected, this menu will not appear.
	MEDIA MENU	ENABLE/ DISABLE	Enables/disables the media menu. If DISABLE is selected, this menu will not appear.
	COLOR MENU	ENABLE/ DISABLE	Enables/disables the color menu. If DISABLE is selected, this menu will not appear.
	SYS CONFIG MENU	ENABLE/ DISABLE	Enables/disables the system configuration menu. If DISABLE is selected, this menu will not appear.
	USB MENU	ENABLE/ DISABLE	Enables/disables the USB menu. If DISABLE is selected, this menu will not appear.
	NETWORK MENU	ENABLE/ DISABLE	Enables/disables the network menu. If DISABLE is selected, this menu will not appear.
	MEMORY MENU	ENABLE/ DISABLE	Enables/disables the memory menu. If DISABLE is selected, this menu will not appear.
	SYS ADJUST MENU	ENABLE/ DISABLE	Enables/disables the system adjust menu. If DISABLE is selected, this menu will not appear.

ITEM	SUB-MENU	SETTINGS	EXPLANATION
	MAINTENANCE MENU	ENABLE/ DISABLE	Enables/disables the maintenance menu. If DISABLE is selected, this menu will not appear.
	USAGE MENU	ENABLE/ DISABLE	Enables/disables the usage menu. If DISABLE is selected, this menu will not appear.
	Config Menu		
	NEARLIFE STATUS	ENABLE/ DISABLE	Enables/disables the LED control when NearLife warning of a toner, drum, fuser, or belt occurs.
	NEARLIFE LED	ENABLE/ DISABLE	Attention LED is lighted when enabled, not lighted when disabled. (Displays LCD message). The status (Life warning) of temporary recovery by opening and closing of the cover is not included.
	PEAK POW CONTROL	NORMAL/LOW	Sets level of peak power control.
	FILE SYS MAINT1		
	FLASH INITIALIZE	EXECUTE	Initializes the resident flash memory. The following message appears when pressing the enter button. ARE YOU SURE? YES/NO If NO is selected, the printer will go back to the source menu. If YES is selected, the printer will be automatically rebooted and initialize the flash memory.
	FILE SYS MAINT2		
	INITIAL LOCK	YES/NO	If YES is selected ADMIN MENU will not appear - FILE SYS MAINT !
	LANGUAGE MENU		
	LANG INITIALIZE	EXECUTE	Initializes the message file loaded in flash memory. The following message for confirmation will appear by pressing the enter button. ARE YOU SURE? YES/NO If NO is selected, the printer will go back to the source menu. The procedure for clearing disk will start immediately after the menu is rebooted
	CHANGE PASSWORD		
	NEW PASSWORD	*****	Set a new password for entering administrator's menu. From 4 to 12 alpha/numerical digits can be entered.
	VERIFY PASSWORD	*****	Verifies the new password set above.

PRINT STATISTICS MENU

This menu should only be changed by the System Administrators. In order to gain access to this menu, follow the instructions in ["How to change the settings - Administrator"](#) on page 38 but hold down the MENU UP button instead of the **Enter** button.

This menu is in **ENGLISH** only (default settings in bold type).

ITEM	SETTINGS	EXPLANATION
Enter Password	XXXX	Enters a password to enter Print Statistics menu. The default value is "0000". The password for entry to Print Statistics is different from the password for entry to Functions-Admin Setup. "Print Statistics" category is not shown when Print Statistics function is not supported.
Usage Report	Enable /Disable	Enables/Disables the printing of the Usage Report. When changing a setting value, the printer is rebooted.
Group Counter	Enable/ Disable	Specifies if the Group counter is displayed in the Usage Report Print. Enable : Displayed. Disable : Not displayed. Conditions for display: Enable must be selected in Functions/Print Statistics/ Usage Report.
Supplies Report	Enable /Disable	Enables/disables the Supplies Report. Enable must be selected in Functions/Print Statistics/ Usage Report.
Reset Main Counter	Execute	Resets the main counter to zero. When executing this menu, resets the main counter to zero and exits from the menu. Enable must be selected in Functions/Print Statistics/ Usage Report.
Reset Supplies Counter	Execute	Resets the Supplies counter to zero.
Change Password		Changes the password. Enable must be selected in Functions/Print Statistics/ Usage Report
New Password	xxxx	Sets a new password to enter Print Statistics menu.
Verify Password	xxxx	Re-enter new password set to enter Print Statistics set in New Password for confirmation.

MENU FUNCTIONS - C821 AND C830

This section lists the menus accessed via the controls on the printer's operator panel and displayed in the LCD window.

OPERATOR PANEL

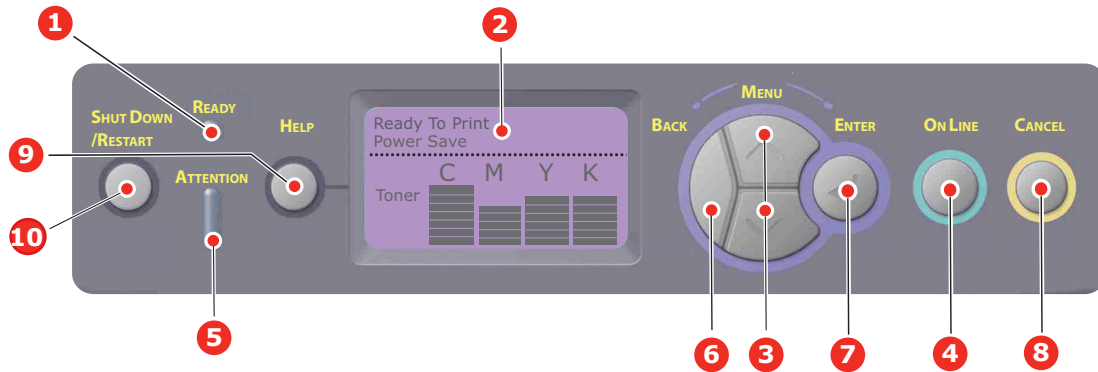

1. Ready LED	ON: Ready to receive data. BLINKING: Processing data. OFF: Offline.	2. Display	Displays the printer status and any error messages.
3. Menu Buttons	Enters the Menu mode. In Menu mode, forwards or reverses the menu item displayed. Press for 2 secs. or longer to fast forward or reverse.	4. On Line Button	Switches between ONLINE and OFFLINE . Exits the menu and goes ONLINE when pressed in the Menu mode. Forces printing on the paper currently loaded when pressed with "WRONG PAPER" or "WRONG PAPER SIZE" displayed.
5. Attention LED	ON: A warning occurs. Printing not possible (e.g empty toner). BLINKING: An error occurs. Printing may be possible (e.g. toner low). OFF: Normal condition.	6. Back Button	Returns to the previous higher level menu item or exits menu & returns printer to "Ready to Print".
7. Enter Button	In the ONLINE or OFFLINE mode: enters the Menu mode. In the Menu mode: determines the setting selected. Advances through the menu structure.	8. Cancel Button	Deletes the data being printed or received when pressed for two seconds or longer. Deletes the data when pressed for two seconds or longer with, e.g., WRONG PAPER SIZE displayed. Exits the menu and goes ONLINE when pressed in the Menu mode.
9. Help Button	Provides advice when an error such as incorrect paper size occurs	10. Shut Down/Restart Button	When held for a few seconds carries out the correct shutdown/restart procedure to prevent possible machine damage

HOW TO CHANGE THE SETTINGS - USER

It should be noted that many of these settings can be, and often are, overridden by settings in the Windows printer drivers. However, several of the driver settings can be left at "Printer Setting", which will then default to the settings entered in these printer menus.

Where applicable, factory default settings are shown in bold type in the following tables.

In the normal operating condition, known as "standby," the printer's LCD window will show "Ready to Print". In this condition, to enter the menu system, press the up and down Menu buttons on the operator panel to move up and down through the list of menus until the menu you wish to view is displayed. Then proceed as follows:

1. Press **Enter** to enter the menu.
2. Use the up or down **Menu** buttons on the control panel to scroll through the menus. When the item you want to change is displayed, press Enter to view the sub-menus for that item.
3. Use the up or down **Menu** buttons to move up and down through the sub-menu items. When the item you want to change is displayed press Enter to display the setting.
4. Use the up or down **Menu** buttons to move up and down through the available settings for the sub-menu item. When the item you want to change is displayed press Enter to display the setting. An asterisk (*) will appear next to the setting, indicating that this setting is currently in effect.
5. Do one of the following:
 - > Press **Back** again to move up to the list of menus;or...
 - > Press **On Line** or **Cancel** to exit from the menu system and return to standby.

NOTE:

*When you have changed any settings in the USB menu, turn the printer **OFF**, then **ON** again.*

HOW TO CHANGE THE SETTINGS - ADMINISTRATOR

You can set whether to **ENABLE** or **DISABLE** each category in the user menu.

Disabled categories are not displayed in the User's menu. Only a system administrator can change these settings.

1. Turn **OFF** the printer.
2. Turn **ON** the printer while pressing the **Enter** button. When **Boot Menu** appears, take your finger off the button.
3. Press the **Enter** button.
4. When **Enter Password** appears, press the **up or down MENU** button, each time followed by **Enter**, then **Enter** several times to input the 1st line of the your password, and then press the **Enter** button.
Enter your 4 to 9 digit password.
(The default password is aaaaaa).
5. Press the **Enter** button.
6. Press the up or down **Menu** button until the "category" you want to change is displayed.
7. When it is, press the **Enter** button.
8. Press the up or down **Menu** button until the "item" you want to change is displayed.

9. When it is displayed, press the **Enter** button.
10. Using the MENU **up** button or MENU **down** button, identify the parameter as required.
11. Press the **Enter** button to enter an asterisk (*) on the right side of the setting selected.
12. Press the **On Line** button to switch to online. The machine will automatically re-boot.

CONFIGURATION MENU

ITEM	ACTION	EXPLANATION
Tray Count	Tray1 Tray 2* Tray 3* MP Tray *Note: Only available when optional trays are present	Select an item to display the total number of pages printed from the relevant tray.
Supplies Life	Cyan Drum Magenta Drum Yellow Drum Black Drum Belt Fuser Cyan Toner Magenta Toner Yellow Toner Black Toner	Select item to display the percentage of a consumable remaining.
Network	Printer Name Short Printer Name IP Address Subnet Mask Gateway Address MAC Address Network FW Version Web Remote version	Displays the full printer name. Displays an abbreviated version. Displays the IP Address Subnet of the network. Displays the Subnet Mask. Displays the Gateway of the network. Displays the Mac Address of the printer. Displays the Network firmware revision. Displays the Web remote version.
System	Serial Number Asset Number CU Version PU Version Total Memory Flash Memory HDD	Displays information for these items.

PRINT INFORMATION MENU

This menu provides a quick method of listing various items stored within the printer.

ITEM	ACTION	EXPLANATION
Configuration	Execute	Select execute to print out a configuration report.
Network	Execute	Scroll down to this parameter and select execute to print out Network information.
Demo Page DEMO1	Execute	Scroll down to this parameter and select execute to print out a demonstration page.
File List	Execute	Scroll down to this parameter and select execute to print out a list of job files. (displayed only if FileSystem is installed).
PS Font List	Execute	Scroll down to this parameter and select execute to print out a Postscript emulation typeface list.
PCL Font List	Execute	Scroll down to this parameter and select execute to print out a PCL font list.
IBM PPR Font List	Execute	Scroll down to this parameter and select execute to print out an IBM PPR font list (must be enabled in System Maintenance).
EPSON FX Font List	Execute	Scroll down to this parameter and select execute to print out an Epson FX emulation font list (must be enabled in System Maintenance).
Usage Report	Execute	Scroll down to this parameter and select execute to print out a list of colour and mono pages printed.
Error Log	Execute	Scroll down to this parameter and select execute to print out the error log.
Color Profile List	Execute	Scroll down to this parameter and select execute to print out a list of colour profiles.

PRINT SECURE JOB

*NOTE:
Only present if an optional Hard disk Drive (HDD) is fitted.*

ITEM	ACTION	EXPLANATION
Encrypted Job	Not Found Print Delete	<p>Used for printing an encrypted authentication print job (Encrypted Job) stored in HDD.</p> <p>After inputting a password, "Searching Job" is displayed until a job appropriate for the password is found.</p> <p>(Searching time increases in proportion to the number of jobs stored in HDD, and the printer may take up to 20 sec.)</p> <p>The search can be cancelled by holding down the Cancel button.</p> <p>Not Found will be displayed where a file, which could be printed is not available.</p> <p>The following message will appear if a printable file is available.</p> <p>Encrypted Job</p> <p>Print</p> <p>Delete</p> <p>A set of all jobs will be printed if Print is selected and the Enter button is pressed.</p> <p>The following message will appear if Delete is selected:</p> <p>Are You Sure?</p> <p>Yes</p> <p>No</p> <p>The display will return to the source menu if No is selected.</p> <p>All jobs will be deleted if Yes is selected.</p> <p>Print jobs with encrypted authentication stored in HDD are deleted by a delete method specified by the driver after printing or a delete instruction from the menu.</p>
Stored Job	Not Found Print Delete	<p>Used to print out a stored job in a HDD.</p> <p>Not Found will be displayed where a file, which could be printed is not available.</p> <p>The following message will appear if a printable file is available.</p> <p>Stored Job</p> <p>Print</p> <p>Delete</p> <p>When Print is selected, Set Collating Amount is displayed and the number of pages to print can be specified.</p> <p>Specify the number of pages to print and press the Enter button.</p> <p>The following message will appear if Delete is selected:</p> <p>Are You Sure?</p> <p>Yes</p> <p>No</p> <p>If No is selected, the display will return to the previous menu.</p> <p>If Yes is selected, all jobs will be deleted.</p>

MENUS

ITEM	ACTION	EXPLANATION
Tray Configuration	Paper Feed Tray1 /MP Tray	Select tray (default condition indicated by *) Select by scroll and Enter button. <i>Note: Optional additional trays shown if fitted.</i>
	Auto Tray Switch On/Off	Switches Auto ON/OFF (default condition indicated by *). Select by scroll and Enter button.
	Tray Sequence Down/Up/Paper Feed	Selects Tray sequence Down/Up/Paper feed Tray (default condition indicated by *). Select by scroll and Enter button.
	Unit of Measurement inch/ millimeter	Selects UOM Inches or millimeter (default condition indicated by *). Select by scroll and Enter button.
	Tray1 Config Default: Paper size: Cassette Size / Custom Media Type: Plain /Letterhead/ Bond/Recycled/ Card Stock/ Rough/Glossy/ *User type 1 - 5 Media Weight: Light /Medium Light/Medium/ Heavy	Configure Paper Size/Media Type/Media Weight . Defines default condition (indicated by *) Select by scroll and Enter button. *User type 1 to 5 are displayed only if registered in the host PC.
	Tray 2 Config (if fitted) Default: Paper size: Cassette Size / Custom Media Type: Plain /Letterhead/ Bond/Recycled/ Card Stock/ Rough/Glossy/ *User type 1 - 5 Media Weight: Light /Medium Light/Medium/ Heavy	Configure Paper Size/Media Type/Media Weight . Defines default condition (indicated by *) Select by scroll and Enter button. *User type 1 to 5 are displayed only if registered in the host PC.
	Tray 3 Config (if fitted) Default: Paper size: Cassette Size / Custom Media Type: Plain /Letterhead/ Bond/Recycled/ Card Stock/ Rough/Glossy/ *User type 1 - 5 Media Weight: Light /Medium Light/Medium/ Heavy	Configure Paper Size/Media Type/Media Weight . Defines default condition (indicated by *) Select by scroll and Enter button. *User type 1 to 5 are displayed only if registered in the host PC.

ITEM	ACTION	EXPLANATION
Tray Configuration (cont.)	<p>MP Tray Config</p> <p>Paper size: A3/A4 Short Edge A4 Long Edge A5/A6/B4/B5 SEF/ B5 LEF/Legal14/ Legal13.5/ Legal13/Tabloid/ Letter Short Edge/ Letter Long Edge/ Executive/Custom/ Com-10 Envelope/ DL Envelope/C5/C4</p> <p>Media Type: Plain/ Letterhead/ Transparency/ Labels/Bond/ Recycled/Card Stock/Rough/ Glossy/ *Usertype 1-5</p> <p>Media Weight: Light/Medium Light/Medium/ Heavy/ Ultra Heavy1/ Ultra Heavy2</p> <p>Tray usage: Do Not Use/ When Mismatching</p>	<p>Configure Paper Size/Media Type/Media Weight/Tray Usage. Defines default condition (indicated by *) Select by scroll and Enter button.</p> <p>*User type 1 to 5 are displayed only if registered in the host PC.</p> <p>Paper weight 189 ~ 220g/m²</p> <p>Sets MPTray usage. When Mismatching: if paper mismatch occurs, paper is requested from the MPTray instead of the specified tray. Do Not Use: sets MPTray unavailable both in Auto Tray Select and Auto Tray Switch.</p>
System Adjust	<p>Power Save Time Default: 1</p> <p>Clearable Warning Default: ONLINE</p> <p>Auto Continue Default: Off</p> <p>Manual Timeout Default: 60</p> <p>Wait Timeout Default: 40</p> <p>Low Toner Default: Continue</p> <p>Jam Rcovery Default: On</p> <p>Error Report Default: Off</p>	<p>Select from 1 / 3 / 5/10/15/30/60/240 Minutes (default condition indicated by *). Select by scroll and Enter button.</p> <p>Select from: ONLINE/Job (default condition indicated by *). Select by scroll and Enter button. PS job only.</p> <p>Select from On/Off (default condition indicated by *). Select by scroll and Enter button.</p> <p>Select from Off/30 seconds/60 seconds (default condition indicated by *). Select by scroll and Enter button.</p> <p>Select from Off/5/10/20/30/40/50/60/90/120/150/180/210/240/270/300 seconds (default condition indicated by *). Select by scroll and Enter button.</p> <p>Select action to take when toner sensor indicates low toner. Select from Continue/Stop (default condition indicated by *). Select by scroll and Enter button.</p> <p>Select from On/Off (default condition indicated by *). Select by scroll and Enter button.</p> <p>Select from On/Off (default condition indicated by *). Select by scroll and Enter button.</p>

ITEM	ACTION	EXPLANATION
System Adjust (cont.)	Print Position Adjust Default: 0.00	Select from X Adjust/Y Adjust/Duplex X Adjust/Duplex Y Adjust (default condition indicated by *). Select by scroll and Enter button. Define measurement.
	Paper Black Settings -2/-1/0/+1/+2 Default: 0	Used for fine adjustment of the black print on paper.
	Paper Color Settings -2/-1/0/+1/+2 Default: 0	Used for fine adjustment of the colour print on paper.
	Trans. Black Settings -2/-1/0/+1/+2 Default: 0	Used for fine adjustment of the black print on transparencies.
	Trans. Color Settings -2/-1/0/+1/+2 Default: 0	Used for fine adjustment of the colour print on transparencies.
	SMR Setting +3/+2/+1/-1/-2/-3/ Default: 0	To correct variations in print results caused by temperature/humidity conditions and difference in print density/frequency. Change the setting when print quality is uneven.
	BG Setting +3/+2/+1/-1/-2/-3/ Default: 0	To correct variations in print results caused by temperature/humidity conditions and difference in print density/frequency. Change the setting when background is dark.
	Drum Cleaning Default: Off	Sets whether to rotate the drum in idle prior to printing in order to reduce horizontal white lines. Be warned that this will shorten the ID life by as much as this rotation (default condition indicated by *). Select by scroll and Enter button.
	Hex Dump Execute	Prints out data received from the host PC in the hexadecimal Dump. Turning off the power supply switch restores Normal Mode.

SHUTDOWN MENU

This menu only appears if the hard disk drive is installed.

This item should always be selected before switching the printer off, to ensure that no hard disk data is lost.

If using the Operator panel button instead, keep pressed for approximately 5 seconds

ITEM	SETTINGS	EXPLANATION
Shutdown Start	Execute	Performs controlled shutdown of the printer, ensuring that all files on the internal hard disk are closed before power is turned off. Only power the printer off when the display indicates that shutdown is complete.

ADMIN SETUP

ITEM		SETTINGS	EXPLANATION
Enter Password		xxxxxxxxxxxx	Enter a password to gain entry to the Admin Setup menu. Password should be from 6 to 12 digits of alpha/numeric characters (or mix) The default value is "aaaaaa"
Network Setup	TCP/IP	Enable Disable	Sets TCP/IP Protocol. Enable: TCP/IP Protocol is available. Disable: TCP/IP Protocol is not available.
	IP Version	IP v4 IP v4+v6	Set up the IP version. Operates with IPv4 for IPv4 (not valid with IPv6). Operates with both IPv4 and IPv6
	NetBEUI	Enable Disable	Sets Enable/Disable of NETBEUI Protocol.
	NetWare	Enable Disable	Sets Enable/Disable of NetWare Protocol.
	EtherTalk	Enable Disable	Sets Enable/Disable of EtherTalk Protocol.
	Frame Type	Auto 802.2 802.3 Ethernet II SNAP	Sets the frame type. Netware should be enabled.
	IP Address Set	Auto Manual	Sets the IP Address setting method. TCP/IP should be enabled.
	IP Address	xxx.xxx.xxx.xxx	Sets the IP Address. TCP/IP should be enabled.
	Subnet Mask	xxx.xxx.xxx.xxx	Sets the Subnet Mask. TCP/IP should be enabled.
	Gateway Address	xxx.xxx.xxx.xxx	Sets the Gateway (default router) address. 0.0.0.0 means that there is no router. TCP/IP should be enabled.
	Web	Enable Disable	Sets Enable/Disable of Web. Enable: Web/IPP is available. Disable: Web/IPP is not available. TCP/IP should be enabled.
	Telnet	Enable Disable	Sets Enable/Disable of Telnet. Enable: Telnet is available. Disable: Telnet is not available. TCP/IP should be enabled.
FTP	Enable Disable	Sets Enable/Disable of FTP. Enable: FTP is available. Disable: FTP is not available. TCP/IP should be enabled.	

ITEM		SETTINGS	EXPLANATION
Network Setup (cont.)	SNMP	Enable Disable	Sets Enable/Disable of SNMP. Enable: SNMP is available. Disable: SNMP is not available. TCP/IP or NetWare should be enabled.
	Network Scale	Normal Small	When Normal is selected, the network can work effectively even when it is connected to a HUB that has a spanning tree feature. However, printer start up time gets longer when computers are connected with two or three small LANs. When Small is selected, computers can cover from two or three small LANs to a large LAN, but may not work effectively when the network is connected to a HUB with a spanning tree feature.
	Hub Link Setting	Auto Negotiate 100Base-TX Full 100Base-TX Half 10Base-T Full 10Base-T Half	Sets a method to link to a HUB. When Auto is set, a connection method to a HUB is selected automatically.
	Factory Defaults?	Execute	Specifies whether to initialize the network factory default settings for the Network.
Print Setup	Personality	Auto PostScript PCL IBM PPR EPSON FX	Selects a printer language.
	Copies	1 - 999	Selects the default number of copies.
	Duplex	On/Off	Specifies Duplex print (option) if a Duplex unit is installed and enabled
	Binding	Long Edge Short Edge	Specifies Binding in duplex printing (if a Duplex unit is installed and enabled)
	Media Check	Enable Disable	Sets whether the printer checks the matching of printed data size and that of the tray. Only standard sizes are checked.
	Resolution	600dpi 600x1200dpi 600dpi multi-level.	Sets default resolution.
	Toner Save Mode	On/Off	This function works effectively only if the data input is color RGB data. This setting is valid in PS and PCL, but does not take effect in the following cases. (1) PS: If Color Matching is set OFF. (2) PS: If any setting other than ASIC Color Matching is set. (3) PS: CMYK data when Ink Simulation Mode is used (valid in any other cases except Case (1) and Case (2) above as long as data is RGB). (4) PCL binary data (Color/Monochrome).

ITEM		SETTINGS	EXPLANATION
Print Setup (cont.)	Mono-Print Speed	Auto Mono 32ppm Color Speed Mixed Speed	<p>If the first page of a print job is black and white, the printer runs at 32ppm (pages per minute). When a colour page is detected the printer slows down to 30ppm (C830) or 26ppm (C821) for the rest of that job.</p> <p>This setting operates in the same way as AUTO SPEED, except that the printer runs at 32ppm until a colour page is detected. To achieve this speed the printer requires an additional time to warm up and cool down when switching to 30ppm (C830) or 26ppm (C821) for colour pages. This setting is therefore most appropriate when the majority of print jobs are entirely black and white.</p> <p>The printer runs at 30ppm (C830) or 26ppm (C821) for all print jobs. This setting is most appropriate when the majority of print jobs are in colour.</p> <p>The printer runs at 26 ppm (C830) or 22ppm (C821) for colour pages and 30 ppm (C830) or 26ppm (C821) for mono pages.</p>
	Default Orientation	Portrait Landscape	<p>Specifies print orientation.</p> <p>Not valid for PS (valid only for PCL/ IBMPPR/EPSONFX/ HP-GL2).</p>
	Form Length	5 lines ~ 64 lines ~ 128 lines	<p>Sets the number of lines that can be printed on a page</p> <p>Not valid for PS (valid only for PCL/HP-GL2).</p> <p>Default values listed to the left are for Letter/A4. In practice, however, they change according to the size of paper loaded in the tray.</p>
	Edit Size	Cassette Size/ A3/A4 Short Edge/A4 Long Edge/A5/A6/B4/B5 Short Edge/B5 Long Edge/Legal14/Legal13.5/Legal13/Tabloid/Letter Short Edge/Letter Long Edge/Executive/Custom/Com-10 Envelope/DL Envelope/C5/C4	<p>Sets the size of an area to draw when the host PC does not specify the size via the paper edit size designating command (Not valid for PS - only for PCL).</p>
	X Dimension	64 mm ~ 210 mm ~ 297 mm	<p>Specifies paper width of Custom paper as a default value.</p> <p>Sets a paper size at right angles to the paper run direction.</p>
	Y Dimension	105 mm ~ 297 mm ~ 1321 mm	<p>Specifies paper length of Custom paper as a default value.</p> <p>Sets a paper size in the same direction as the paper run direction.</p>

ITEM		SETTINGS	EXPLANATION
PS Setup	Network Protocol	ASCII/ RAW	Specifies PS communication protocol mode of data from NIC port. (In RAW mode, Ctrl-T is invalid). PS models only.
	Parallel Protocol	ASCII /RAW	Specifies PS communication protocol mode of data from Centronics port. (In RAW mode, Ctrl-T is invalid). PS models only.
	USB Protocol	ASCII/ RAW	Specifies PS communication protocol mode of data from USB port. (In RAW mode, Ctrl-T is invalid). PS models only.
PCL Setup	Font Source	Resident	Specifies the location of PCL default font.
	Font Number	I0 ~ I90	Sets the PCL font number. The valid range of this variable changes depending on the FONT SOURCE setting at the time. If the default font is set for FONT SOURCE, the number starts at 0. If it is not, the number starts at 1. The maximum value is equal to the number of fonts installed in FONT SOURCE.
	Font Pitch	99.99CPI ~ 10.00CPI ~ 0.44CPI	Width of the PCL default font in characters per inch (CPI). Default font is fixed-pitch, scalable font. The value of pitch is displayed down to the second decimal place. Displayed only when the font selected in Font No. is a fixed-spacing, scalable font.
	Symbol Set	PC-8	Sets the symbol set of PCL (see machine operator panel for complete list).
	A4 Print Width	78 column 80 column	Sets the number of characters for A4 paper. Auto LF. This is for 10-CPI characters when Auto CR/LF Mode is set to OFF. This menu is enabled only when A4 paper is selected in the menu that sets the print width of A4 paper in portrait orientation. Usually, such A4 paper print width is set slightly narrower than 8 inches (about 7.93 inches). This setting cannot print 80 10-cpi characters (only prints up to 78 10-cpi characters). 80 characters set at A4 Print Width widen the right and left margins. A PCL command selects or selects/deselects Auto CR/LF mode.
	White Page Skip	On/ Off	Sets whether to eject a page without any data to print (blank page) upon reception of FF command (OCH) in PCL Mode. OFF: Ejecting.
	CR Function	CR /CR+LF	Sets action when CR code is received in PCL. CR: Carriage Return CR+LF: Carriage Return and Line Feed
	LF Function	LF /LF+CR	Sets action when LF code is received in PCL. LF: Line Feed LF+CR: Line Feed and Carriage Return
	Print Margin	Normal 1/5 inch 1/6 inch	Sets a non-printable area of paper. The width of the area along the right and left sides of paper (left and right sides depend on paper orientation). NORMAL: PCL emulation compatible, approximately 1/4~1/4.3INCH (depending on paper) is outside the printable area.

ITEM		SETTINGS	EXPLANATION
PCL Setup (cont.)	True Black	On/ Off	Sets whether to use Composite Black (cmyk mixed) or Pure Black (K only) for the black (100%) in image data. OFF: Mode using Composite Black ON: Mode using Pure Black (PCL only)
	Pen Width Adjust	On /Off	When minimum width is specified in PCL, sometimes a 1-dot line, looks broken. With PEN WIDTH Adjust set to ON, when the minimum width is specified, the line width will be emphasized so as to look wider than a 1-dot line. With PEN WIDTH Adjust set to OFF, the line will appear as before.
	Tray 2 ID#	1 ~ 5 ~ 59	Sets the # to specify Tray 2 for the paper feed destination command (ESC&I#H) in PCL5e emulation. (Displayed only if Tray 2 is installed).
	Tray 3 ID#	1 ~ 20 ~ 59	Sets the # to specify Tray 3 for the paper feed destination command (ESC&I#H) in PCL5e emulation. (Displayed only if Tray 3 is installed).
	MPTray ID#	1 ~ 4 ~ 59	Sets the # to specify the MP tray for the paper feed destination command (ESC&I#H) in PCL5e emulation.
IBM PPR Setup	Character Pitch	10 CPI 12 CPI 17 CPI 20 CPI Proportional	Specifies character pitch in IBM PPR emulation.
	Font Condense	12CPI to 20CPI 12CPI to 12CPI	Specifies 12CPI pitch for Condense Mode.
	Character Set	SET-2 SET-1	Sets a character set.
	Symbol Set	IBM-437	Sets the Symbol Set for IBM PPR (see machine operator panel for complete list).
	Letter O Style	Enable/ Disable	Specifies the style that replaces ø (9B) and ¥ (9D) with ø (ou) and Ø (zero).
	Zero Character	Normal /Slashed	Specifies the style of 0(zero). SLASHED: SLASH ZERO
	Line Pitch	6/8 LPI	Sets line space.
	White Page Skip	On/ Off	Sets whether to eject a blank sheet. Available only when simplex is set.
	CR Function	CR /CR+LF	Sets action when CR code is received.
	LF Function	LF /LF+CR	Sets action when LF code is received.
	Line Length	80 /136 column	Specifies the number of characters per line.
	Form Length	11/ 11.7 /12 inch	Specifies the length of paper.
	TOF Position	0.0 /0.1/~1.0 inch	Sets the position from the top edge of paper.
Left Margin	0.0 /0.1/~1.0 inch	Sets the amount to shift the horizontal print start position to the right.	

ITEM		SETTINGS	EXPLANATION
IBM PPR Setup (cont.)	Fit to Letter	Enable/ Disable	Sets the printing mode that can fit print data, equivalent to 11 inches (66 lines), in the LETTER-size printable area.
	Text Height	Same /Diff	Sets height of a character. SAME: Regardless of CPI, same height DIFF: According to CPI, character heights vary.
	Continuous Paper Mode	On/ Off	Sets printer for using continuous feed stationary.
EPSON FX Setup	Character Pitch	10 CPI /12 CPI/ 17 CPI 20 CPI/ Proportional	Specifies character pitch in Epson FX emulation.
	Character Set	SET-2 SET-1	Sets a character set.
	Symbol Set	IBM-437	Sets the Symbol Set for Epson FX Emulation. (see machine operator panel for complete list).
	Letter O Style	Enable/ Disable	Specifies the style that replaces ø (9B) and ¥ (9D) with ø (ou) and Ø (zero).
	Zero Character	Normal /Slashed	Specifies the style of 0(zero). SLASHED: SLASH ZERO
	Line Pitch	6/8 LPI	Sets line space.
	White Page Skip	On/ Off	Sets whether to eject a blank sheet. Available only when simplex is set.
	CR Function	CR /CR+LF	Sets action when CR code is received.
	Line Length	80 /136 column	Specifies the number of characters per line.
	Form Length	11/ 11.7 /12 inch	Specifies the length of paper.
	TOF Position	0.0 /0.1/~1.0 inch	Sets the position from the top edge of paper.
	Left Margin	0.0 /0.1/~1.0 inch	Sets the amount to shift the horizontal print start position to the right.
	Fit to Letter	Enable/ Disable	Sets the printing mode that can fit print data, equivalent to 11 inches (66 lines), in the LETTER-size printable area.
	Text Height	Same /Diff	Sets height of a character. SAME: Regardless of CPI, same height DIFF: According to CPI, character heights vary.
	Continuous Paper Mode	On/ Off	Sets printer for using continuous feed stationary.

ITEM		SETTINGS	EXPLANATION
Color Setup	Ink Simulation	Off SWOP Euroscale Japan	The machine has its own process simulation engine which simulates standard colors in the printer. This function is available only with PS language jobs.
	UCR	Low Medium High	Selects limitation to the toner layer thickness. If paper curl occurs in dark printing, selecting MEDIUM or LIGHT sometimes helps reduce this curl. UCR = Under Color Removal.
	CMY 100% Density	Enable/ Disable	Enable/Disable 100% output against the CMY100% TRC compensation. Ordinarily, the TRC compensation function holds control for the appropriate print density; thus 100% output is not always possible. Selecting ENABLE will enable 100% output in any individual color. The actual print, including the TRC compensation function is limited to an appropriate area. This function is for special purposes such as specification in CMYK color reduction in PS.
	CMYK Conversion	On/Off	Setting to "OFF" will simplify the conversion process of CMYK data, which will reduce the processing time. This setting is ignored when Ink Simulation function is used. PS only
Memory Setup	Receive Buffer Size	Auto 0.5 megabyte 1 megabyte 2 megabyte 4 megabyte 8 megabyte 16 megabyte	Sets the size of receive buffer
	Resource Save	Auto Off 0.5 megabyte 1 megabyte 2 megabyte 4 megabyte 8 megabyte 16 megabyte	Sets the size of resource saving area.

ITEM		SETTINGS	EXPLANATION
HDD Setup	This item is displayed only if a HDD (option) is installed.		
	Initialize	Execute	<p>Initializes the HDD to the factory default setting. Machine performs partition-division, and initializes each partition. When this menu is executed, the following confirmation message appears.</p> <p>Are You Sure? Yes/No</p> <p>If No is selected, you will return to the previous menu. If Yes is selected, the following confirmation message appears.</p> <p>Execute Now? Yes/No</p> <p>If No is selected, you will return to the previous menu. The request to execute HDD initialization is put into the memory and initialization will be executed at the next power cycle.</p> <p>If Yes is selected, shutdown takes place, and the HDD is initialized at power Off/On cycle.</p>
Resize Partition	PCL nn%/ Common mm%/ PSll%/<Apply>	<p>Specifies the size of partition. Specifies a size by ratio to the whole HDD in % (1% unit).</p> <p>nn,mm,ll: 1 - 98 and nn+mm+ll=100</p> <p>The sizes are displayed in the partition list and can be changed by selecting the partition size to be changed. If Apply is selected, the following confirmation message appears.</p> <p>Are You Sure? Yes/No</p> <p>If No is selected, you will return to the previous menu. If Yes is selected, the following confirmation message appears.</p> <p>Execute Now? Yes/No</p> <p>If No is selected, you will return to the previous menu. The request to execute the partition size change request is put into the memory and the hard disk initialization and partition size change will be executed at next power cycle.</p> <p>If Yes is selected, shutdown takes place. Hard disk initialization and partition size change will be executed at Power Off/On cycle. (If one partition size is modified, the others are also modified.) If any partition size is modified, Initialization of HDD needs to be executed as well.</p> <p>If a previously used HDD is installed, HDD initialization also takes place. If a HDD, which has been used before, is installed, the layout of this menu may be different from that of each partition. (The previously used layout will be displayed.)</p> <p>In Non-PS machines, PS is replaced by COMMON, so the message is displayed as "PCL/COMMON/COMMON".</p>	

ITEM		SETTINGS	EXPLANATION
HDD Setup (cont.)	Format Partition	PCL Common PS	Formats a specified partition. When the Enter button is pressed, the following confirmation message appears. Are You Sure? Yes/No If No is selected, you will return to the previous menu. If Yes is selected, the following confirmation message appears. Execute Now? Yes/No If No is selected, you will return to the previous menu. The request to execute partition formatting is put into the memory and formatting will be executed at next power cycle. If Yes is selected, shutdown takes place and the partition is formatted at power Off/On cycle. In Non-PS machines, PS is replaced by Common, so the message is displayed as "PCL/Common/Common".
System Setup	Near Life Status	Enable/Disable	Sets the LCD display control when near life warning of a drum, fuser or transfer belt occurs. ATTENTION LED is lit if ENABLED
	Near Life LED	Enable/Disable	Controls the settings of the Attention LED when near end of life warning of toner, drum, fuser, or belt occurs. Attention LED is lit when enabled, not lit if disabled. (Displays LCD message.) The temporary recovery by opening and closing of the cover in Life error is not included.
Change Password	New Password	xxxxxxxxxxxxxx	Sets a new password to enter Admin Setup menu From 6 to 12 alpha/numeric digits can be entered.
	Verify password	xxxxxxxxxxxxxx	Forces the User to input the new password to enter Admin Setup. From 6 to 12 alpha/numeric digits can be entered.
Settings	Reset Settings	Execute	Resets EEPROM of CU. Resets User menu to the factory default. If Execute is selected, exits from the menu.
	Save Settings	Execute	Saves menus currently set. With this function, the menus with which operation was last performed are saved, and overwrites with them menus that were previously saved. When the Enter button is pressed, the following confirmation message appears. Are You Sure? Yes/No When No is selected, the preceding menus are restored. When Yes is selected, the current menu settings are saved and this menu is exited.

CALIBRATION

ITEM		SETTINGS	EXPLANATION
Auto Density Mode		On/Off	Enables/disables automatic density adjustment.
Adjust Density		Execute	If Execute is selected, the printer will immediately adjust density and reflect it in TRC compensation. This adjustment must be executed when the printer is idling. It can become invalid if executed in any other state.
Adjust Registration		Execute	When this menu is selected, the printer performs AutoAdjust Registration. This adjustment must be executed when the printer is idling.
Print Tuning Pattern		Execute	Prints the pattern for the user to adjust TRC. Ordinarily, this function is not needed because TRC is automatically adjusted to the recommended levels through density adjustment and TRC compensation. Adjustment results will be reflected as offset values (addition) to the corrections through the Adjust Density/TRC Compensation function.
Cyan/Magenta/ Yellow/Black Tuning	Highlight	-3,-2,-1, 0,+1,+2,+3,	Adjusts HIGHLIGHT (light area) of the TRC. + = Darker - = Lighter
	Mid-Tone	-3,-2,-1, 0,+1,+2,+3,	Adjusts MID-TONE area of the TRC. + = Darker - = Lighter
	Dark	-3,-2,-1, 0,+1,+2,+3,	Adjusts DARK area of the TRC. + = Darker - = Lighter
Cyan/Magenta/ Yellow/Black Darkness		-3,-2,-1, 0,+1,+2,+3,	Adjusts the engine density. The Darkness settings for each of CMYK will be reflected as offset values (addition) to the corrections through the Adjust Density/TRC Compensation function.

ADMINISTRATOR (BOOT) MENU

This menu should only be changed by the System Administrators. In order to gain access to this menu, follow the instructions in ["How to change the settings - Administrator" on page 49](#).

This menu is in ENGLISH only (default settings in bold type).

Parallel setup

This menu controls the operation of the printer's Parallel data interface.

ITEM	SETTINGS	EXPLANATION
Enter Password	xxxxxxxxxxxx	Enter a password to gain entry to the Admin menu. Password should be from 6 to 12 digits of alpha/numeric characters (or mix) The default value is "aaaaaa" The printer will restart after the Boot Menu.
Parallel	Enable / Disable	Enables or disables the parallel port.
Bi-Direction	Enable / Disable	ENABLE/DISABLE the bi-directional capability of the parallel interface.
ECP	Enable / Disable	Extended Capabilities Port, enables/disables this function.
ACK Width	Narrow / Medium/ Wide	Sets ACK width for compatible reception. = 0.5 μ s = 1.0 μ s = 3.0 μ s
ACK/Busy Timing	Ack in Busy / Ack while Busy	Sets the order to output the BUSY and ACK signal for compatible reception.
I-Prime	Disable / 3 μ sec/50 μ sec	Sets time to enable/disable I-prime signal
Offline Receive	Enable / Disable	To Enable/disable of this function. When set to Enable, the interface retains a receive possible state even when switching to Offline. Interface sends the BUSY signal only when the receive buffer is full or a service call occurs.

USB setup

This menu controls the operation of the printer's USB data interface.

ITEM	SETTINGS	EXPLANATION
USB	Enable / Disable	ENABLES / DISABLES the USB port.
Speed	12 / 480 Mbps	Selects the interface speed. After setting change the menu, the printer restarts on exit.
Soft Reset	Enable / Disable	Enables or disables the SOFT RESET command.
Offline Receive	Enable / Disable	OFFLINE RECEIVE.
Serial Number	Enable / Disable	Specifies whether to ENABLE or DISABLE a USB serial number. The USB serial number is used to identify the USB device connected to your PC.

NOTE

When you have changed any settings in the USB MENU, turn the printer OFF, then ON again.

Security setup

Only available when a Hard Disk (option) is fitted.

ITEM	SETTINGS	EXPLANATION
Job Limitations	Off Encrypted Job	Job limitation mode control. Jobs other than specified ones are rejected.
Reset Cipher Key	Execute	Resets a cipher key to be used on an encrypted hard disk. When this processing is done, all data stored on the hard disk cannot be restored. After execution, the following confirmation messages will appear. Are You Sure? Yes No If No is selected, the display will return to the previous menu. If Yes is selected, the printer will be automatically rebooted and the resetting of the cipher key will be executed.

Storage system

Only available when a Hard Disk (option) is fitted.

ITEM	SETTINGS	EXPLANATION
Check File System	Execute	Resolves mismatch between actual memory and displayed memory available in a file system. Performs administration data (FAT information) recovery. Performs recovery only for an HDD.
Check All Sectors	Execute	Performs recovery of defective HDD sector information and a file system mismatch mentioned above. The target device is only a HDD and it takes 30 to 40 minutes to complete this function for an HDD of 10GB.
Enable HDD	Yes No	Even if a machine is inoperable at installation because of a faulty HDD, the machine can be made operable by setting this parameter to No (ignores the existence of the HDD). When No is set, access to a HDD results in FAIL because the HDD is regarded as not attached. After setting change and exit from the menu, the printer will restart.

ITEM	SETTINGS	EXPLANATION
Erase HDD	Execute	<p>Deletion of all data stored in the hard disk. DoD 5220.22-M sanitizing formula is used for clearing the disk. The machine will restart after changing setup. The following message appears after pressing the Enter switch.</p> <p>Are You Sure? Yes No</p> <p>If NO is selected, you will be returned to the source menu</p> <p>If Yes is selected the procedure for clearing disk will start immediately after the machine reboots.</p> <p>If the Cancel button is held down during erasing, the following confirmation messages will appear to discontinue processing.</p> <p>Do You Wish to Cancel? Yes No</p> <p>If NO is selected, the procedure will continue. If YES is selected, the procedure will discontinue.</p>
Enable initialization	No Yes	Prevents a setting change accompanying initialization of Block Device (HDD,FLASH).

Storage setup

ITEM	SETTINGS	EXPLANATION
Enable initialisation	Yes/No	

Power setup

ITEM	SETTINGS	EXPLANATION
Peak Power Control	Normal/Low	Sets peak Power control level.
Power Save	Enable Disable	Sets Enable/Disable of Power Save Mode.
USB Host Power	Off/On	<p>Sets power supply for USB-HOST of the whole power save mode.</p> <p>When Off, suppress power supply. When On, do normal power supply.</p>

Language setup

ITEM	SETTINGS	EXPLANATION
Language Initialize	Execute	<p>Initialises the message file loaded in FLASH.</p> <p>When you press the Enter button, the following message, requesting confirmation, will appear,</p> <p>Are You Sure? Yes No</p> <p>If NO is selected, you will be returned to the source menu.</p> <p>The procedure for clearing the disk will start immediately after the menu and rebooting.</p>

PRINT STATISTICS MENU

This menu should only be changed by the System Administrators. In order to gain access to this menu, follow the instructions in ["How to change the settings - Administrator" on page 49](#), but hold down the **Menu** button instead of the **Enter** button.

This menu is in **ENGLISH** only (default settings in bold type).

ITEM	SETTINGS	EXPLANATION
Enter Password	XXXX	Enters a password to enter Print Statistics menu. The default value is "0000". The password for entry to Print Statistics is different from the password for entry to Functions-Admin Setup. "Print Statistics" category is not shown when Print Statistics function is not supported.
Usage Report	Enable /Disable	Enables/Disables the printing of the Usage Report. When changing a setting value, the printer is rebooted.
Group Counter	Enable/ Disable	Specifies if the Group counter is displayed in the Usage Report Print. Enable : Displayed, Disable : Not displayed. Conditions for display: Enable must be selected in Functions/Print Statistics/ Usage Report.
Supplies Report	Enable /Disable	Enables/disables the Supplies Report. Enable must be selected in Functions/Print Statistics/ Usage Report.
Reset Main Counter	Execute	Resets the main counter to zero. When executing this menu, resets the main counter to zero and exits from the menu. Enable must be selected in Functions/Print Statistics/ Usage Report.
Reset Supplies Counter	Execute	Resets the Supplies counter to zero.
Change Password		Changes the password.
New Password	xxxx	Sets a new password to enter Print Statistics menu.
Verify Password	xxxx	Re-enter new password set to enter Print Statistics set in New Password for confirmation.

MAINTENANCE

REPLACING CONSUMABLE ITEMS

This section explains how to replace consumable items when due.

NOTE:

When the LCD display indicates TONER LOW, or if print appears faded, first open the top cover and try tapping the cartridge a few times to evenly distribute the toner powder. This will enable you to obtain the best "yield" from your toner cartridge.

TONER CARTRIDGE REPLACEMENT

CAUTION!

To avoid toner wastage and possible toner sensor errors, do not change the toner cartridge(s) until "TONER EMPTY" is displayed.

For the protection of your product, and in order to ensure that you benefit from its full functionality, this model has been designed to operate only with genuine original toner cartridges. Any other toner cartridge may not operate at all, even if it is described as "compatible", and if it does work, your product's performance and print quality may be degraded.

Non-genuine original products may invalidate your warranty.

The toner used in this printer is a very fine dry powder. It is contained in four cartridges: one each for cyan, magenta, yellow and black.

Have a sheet of paper handy so that you have somewhere to place the used cartridge while you install the new one.

Dispose of the old cartridge responsibly, inside the pack that the new one came in. Follow any regulations, recommendations, etc., which may be in force concerning waste recycling.

If you do spill any toner powder, lightly brush it off. If this is not enough, use a cool, damp cloth to remove any residue.

Do not use hot water, and never use solvents of any kind. They will make stains permanent.

WARNING!

If you inhale any toner or get it in your eyes, drink a little water or bathe your eyes liberally in cold water. Seek medical attention immediately.

1. Press the cover release and open the printer's top cover fully.

WARNING!

If the printer has been powered on, the fuser may be hot. This area is clearly labelled. Do not touch.

2. Note the positions of the four toner cartridges (a) and image drums (b). It is essential that they go back in the same order.

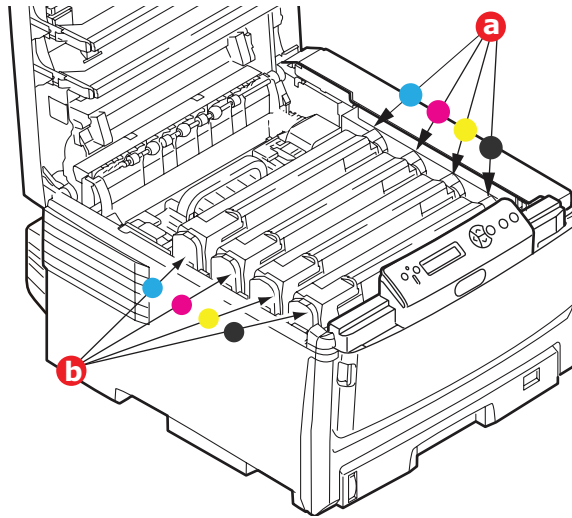

3. Pull the coloured toner release lever (a) on the cartridge to be replaced fully towards the front of the printer.

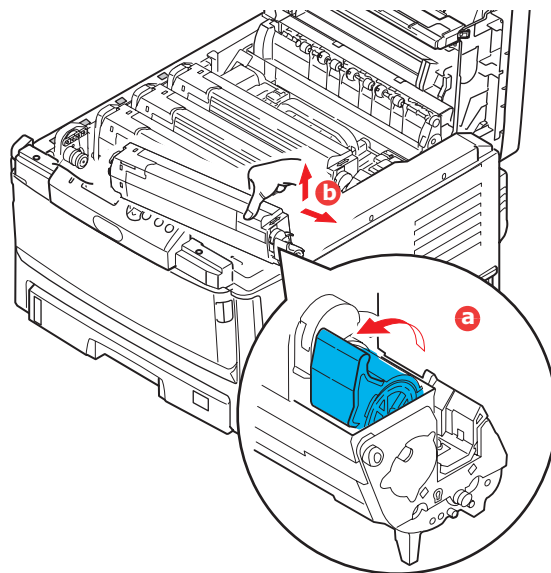

4. Lift the right-hand end of the cartridge and then draw the cartridge to the right to release the left-hand end as shown, and withdraw the toner cartridge (b).
5. Put the assembly down gently onto a piece of paper to prevent toner from marking your furniture.
6. Remove the new cartridge from its box but leave its wrapping material in place for the moment.

7. Gently shake the new cartridge from end to end several times to loosen and distribute the toner evenly inside the cartridge.

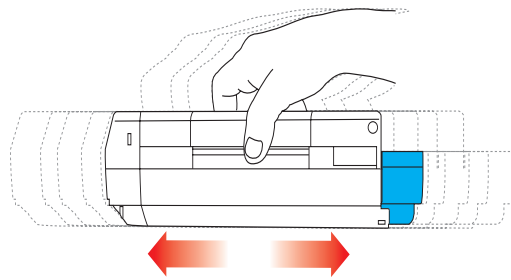

8. Remove the wrapping material and peel off the adhesive tape from the underside of the cartridge.

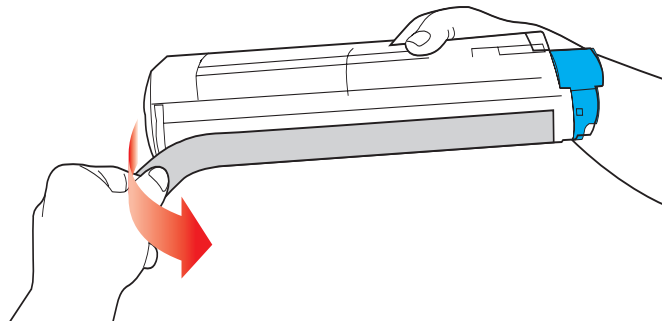

9. Holding the cartridge by its top centre with the coloured lever to the right, lower it into the printer over the image drum unit from which the old cartridge was removed.
10. Insert the left end of the cartridge into the top of the image drum unit first (a), pushing it against the spring on the drum unit, then lower the right end of the cartridge down onto the image drum unit (b).

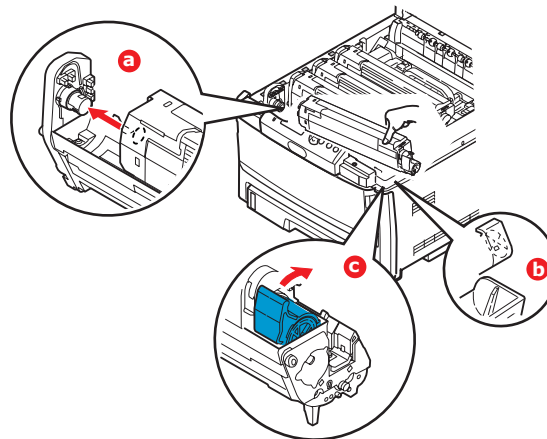

11. Pressing gently down on the cartridge to ensure that it is firmly seated, push the coloured lever (c) towards the rear of the printer. This will lock the cartridge into place and release toner into the image drum unit.
12. Finally, close the top cover and press down firmly at both sides so that the cover latches closed.

IMAGE DRUM REPLACEMENT

CAUTION!



Static sensitive devices, handle with care.

The printer contains four image drums: cyan, magenta, yellow and black.

1. Press the cover release and open the printer's top cover fully.

WARNING!

If the printer has been powered on, the fuser will be hot. This area is clearly labelled. Do not touch.

2. Note the positions of the four cartridges (a) and image drums (b). It is essential that they go back in the same order.

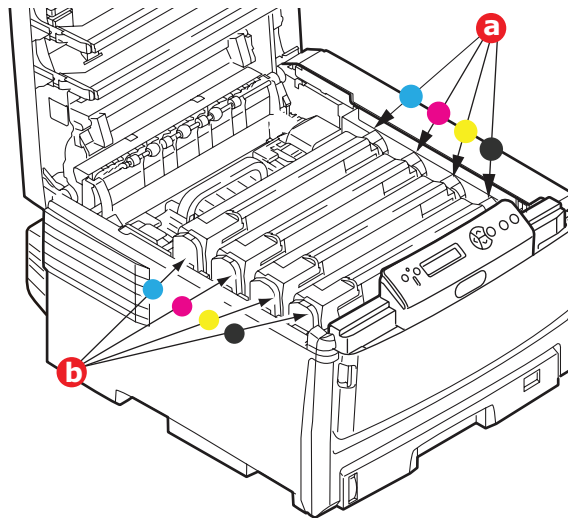

3. Holding it by its top centre, lift the image drum, complete with its toner cartridge, up and out of the printer.

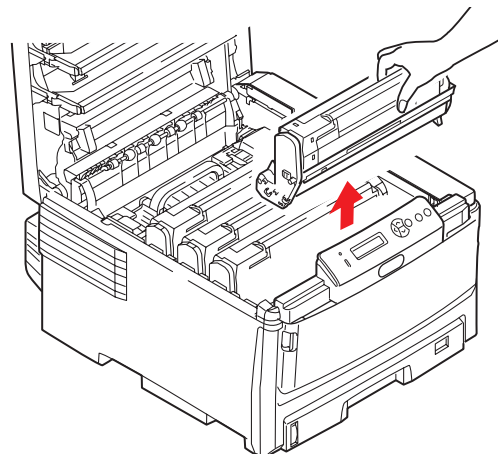

- Put the assembly down gently onto a piece of paper to prevent toner from marking your furniture and to avoid damaging the green drum surface.

CAUTION!

The green image drum surface at the base of the cartridge is very delicate and light sensitive. Do not touch it and do not expose it to normal room light for more than 5 minutes. If the drum unit needs to be out of the printer for longer than this, please wrap the cartridge inside a black plastic bag to keep it away from light. Never expose the drum to direct sunlight or very bright room lighting.

- With the coloured toner release lever to the right, pull the lever towards you. This will release the bond between the toner cartridge and the image drum cartridge.

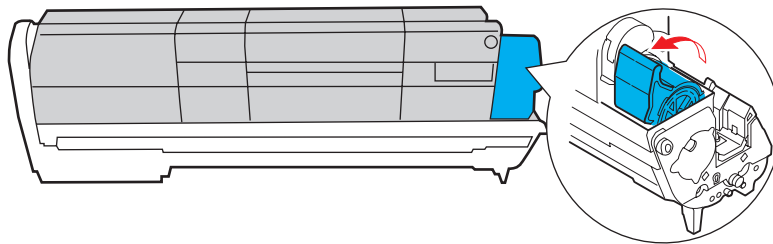

- Lift the right-hand end of the cartridge and then draw the cartridge to the right to release the left-hand end as shown, and withdraw the toner cartridge out of the image drum cartridge. Place the cartridge on a piece of paper to avoid marking your furniture.

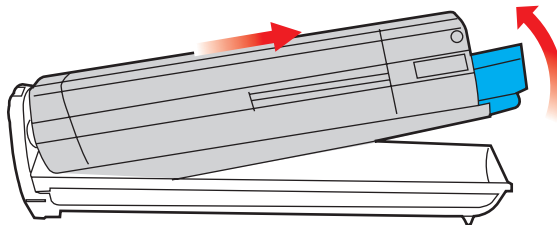

- Take the new image drum cartridge out of its packaging and place it on the piece of paper where the old cartridge was placed. Keep it the same way round as the old unit. Pack the old cartridge inside the packaging material for disposal.
- Place the toner cartridge onto the new image drum cartridge as shown. Push the left end in first, and then lower the right end in. (It is not necessary to fit a new toner cartridge at this time unless the remaining toner level is very low.)

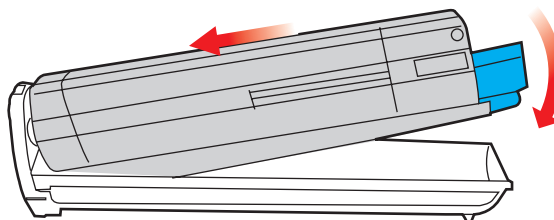

9. Push the coloured release lever away from you to lock the toner cartridge onto the new image drum unit and release toner into it.

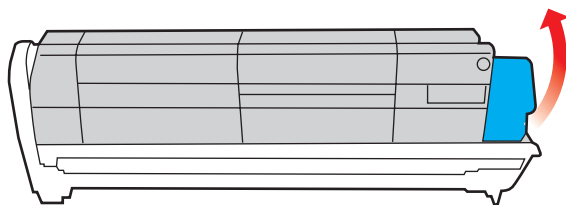

10. Holding the complete assembly by its top centre, lower it into place in the printer, locating the pegs at each end into their slots in the sides of the printer cavity.

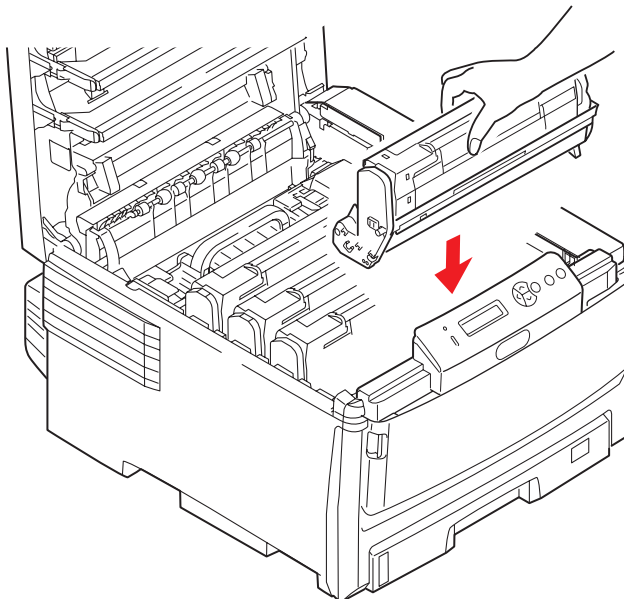

11. Finally, close the top cover and press down firmly at both sides so that the cover latches closed.

NOTE:

If you need to return or transport your printer for any reason, please make sure you remove the image drum unit beforehand and place in the bag provided. This is to avoid toner spillage.

TRANSFER BELT REPLACEMENT

The belt unit is located under the four image drums.

Switch off the printer and allow the fuser to cool for about 10 minutes before opening the cover.

1. Press the cover release and open the printer's top cover fully.

WARNING!

If the printer has been powered on, the fuser will be hot. This area is clearly labelled. Do not touch.

2. Note the positions of the four toner cartridges (a) and image drums (b). It is essential that they go back in the same order.

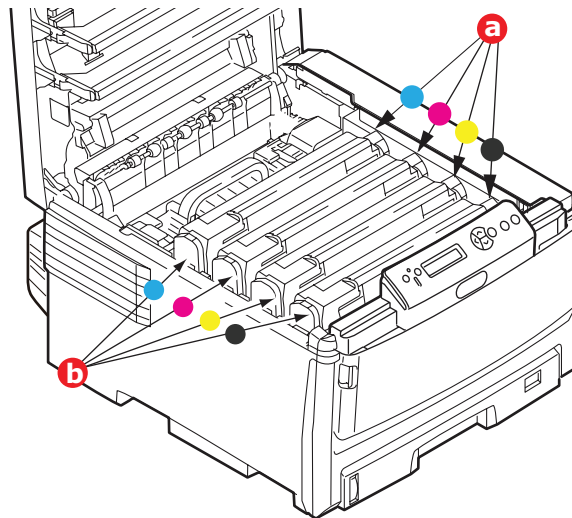

3. Lift each of the image drum units out of the printer and place them in a safe place away from direct sources of heat and light.

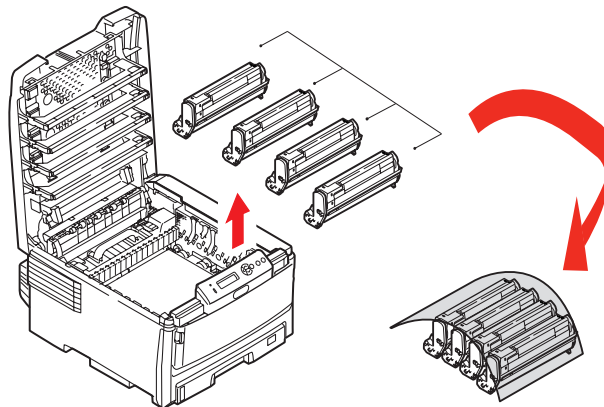

CAUTION!

The green image drum surface at the base of each cartridge is very delicate and light sensitive. Do not touch it and do not expose it to normal room light for more than 5 minutes. If the drum unit needs to be out of the printer for longer than this, please wrap the cartridge inside a black plastic bag to keep it away from light. Never expose the drum to direct sunlight or very bright room lighting.

4. Locate the two fasteners (a) at each side of the belt and the lifting bar (b) at the front end.

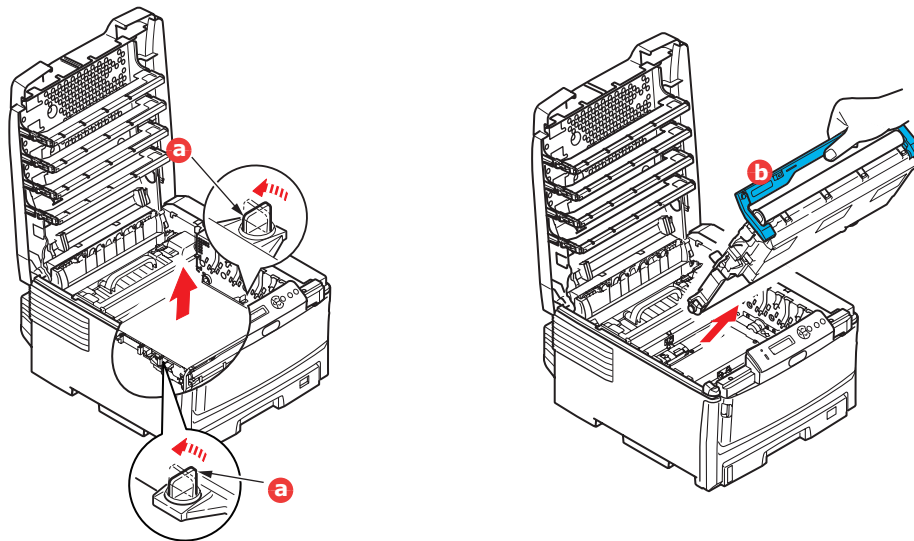

5. Turn the two fasteners 90° to the left. This will release the belt from the printer chassis.
6. Pull the lifting bar (b) upwards so that belt tilts up towards the front, and withdraw the belt unit from the printer.
7. Lower the new belt unit into place, with the lifting bar at the front and the drive gear towards the rear of the printer. Locate the drive gear into the gear inside the printer by the rear left corner of the unit, and lower the belt unit flat inside the printer.

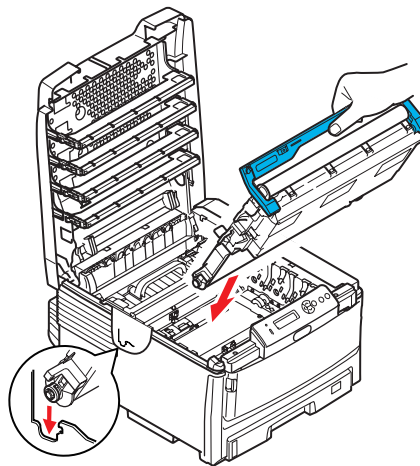

8. Turn the two fasteners (a) 90° to the right until they lock. This will secure the belt unit in place.
9. Replace the four image drums, complete with their toner cartridges, into the printer in the same sequence as they came out: cyan (nearest the rear), magenta, yellow and black (nearest the front).
10. Finally, close the top cover and press down firmly at both sides so that the cover latches closed.

FUSER REPLACEMENT

The fuser is located inside the printer just behind the four image drum units.

WARNING!

If the printer has recently been powered on, some fuser components will be very hot. Handle the fuser with extreme care, holding it only by its handle, which will only be mildly warm to the touch. A warning label clearly indicates the area. If in doubt, switch the printer off and wait at least 10 minutes for the fuser to cool before opening the printer cover.

1. Switch off the printer.
2. Press the cover release and open the printer's top cover fully.
3. Identify the fuser handle (a) on the top of the fuser unit.

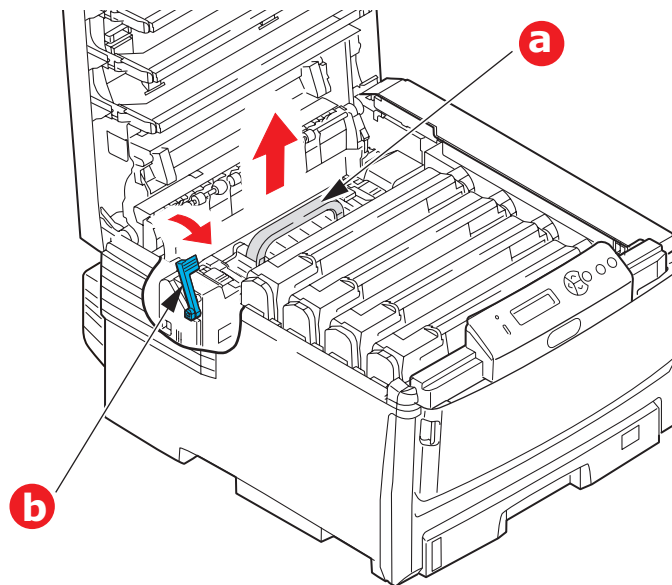

4. Pull the fuser retaining lever (b) towards the front of the printer so that it is fully upright.
5. Holding the fuser by its handle (a), lift the fuser straight up and out of the printer. If the fuser is still warm, place it on a flat surface which will not be damaged by heat.
6. Remove the new fuser from its packaging and remove the transit material.
7. Holding the new fuser by its handle, make sure that it is the correct way round. The retaining lever (b) should be fully upright.
8. Lower the fuser into the printer.

9. Push the retaining lever (b) towards the rear of the printer to lock the fuser in place.

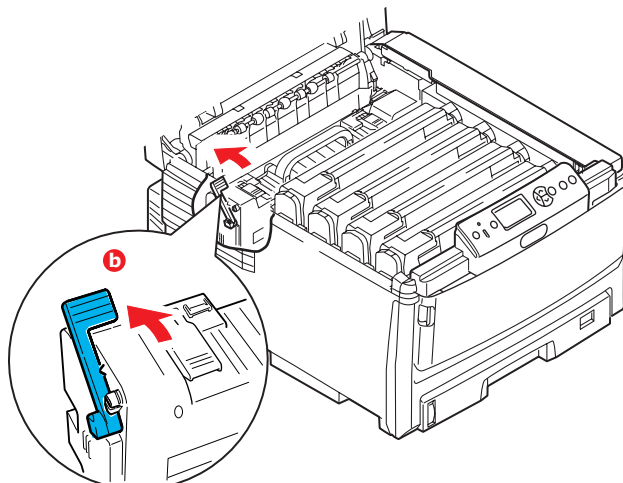

10. Finally, close the top cover and press down firmly at both sides so that the cover latches closed.
11. Switch the printer ON.

CLEANING

CAUTION!

Use a clean, moist, lint-free cloth for cleaning. Do not use benzene, thinners or alcohol as a cleaning agent.

...THE UNIT CASING

1. Switch the printer off.
2. Wipe the unit surface with a soft cloth moistened sparingly with water or neutral detergent.

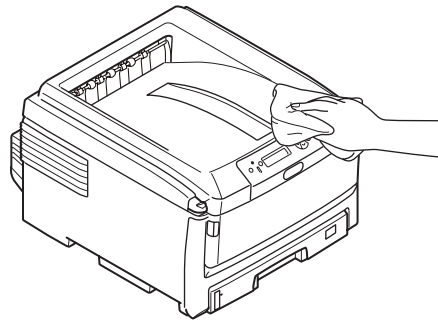

3. Use a soft dry cloth to dry the unit surface.

...THE LED HEAD

Clean the LED head when printing does not come out clearly, has white lines or when text is blurred.

1. Switch off the printer and open the top cover.
2. Gently wipe the LED head surface with a soft tissue.

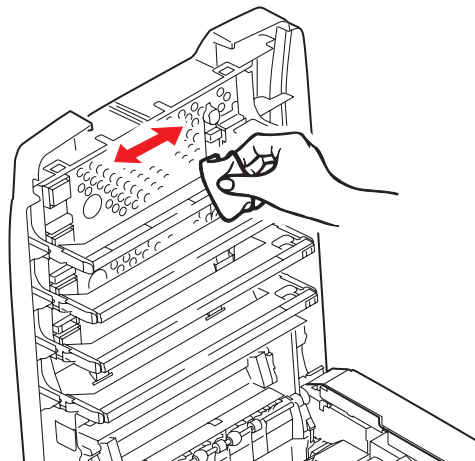

CAUTION!

Do not use methyl alcohol or other solvents on the LED head as damage to the lens surface will occur.

3. Close the top cover.

...THE PAPER FEED ROLLERS

CAUTION!

Use a clean, moist, lint-free cloth for cleaning. Do not use benzine, thinners or alcohol as a cleaning agent.

Clean the paper feed rollers if paper jams frequently occur.

1. Remove items like a wrist watch or bracelet.
2. Switch the printer off.
3. Remove the paper tray from the printer.

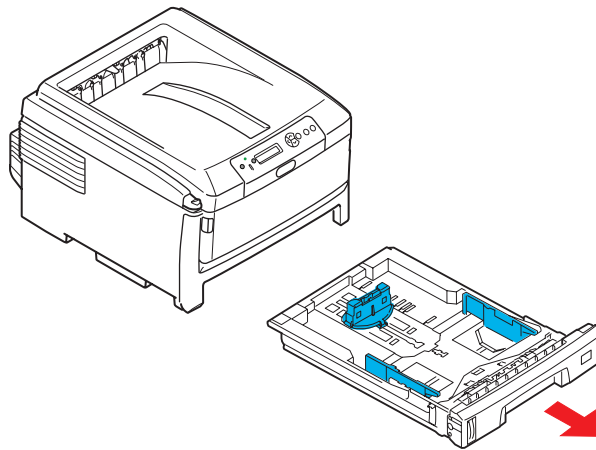

4. Gaining access through the gap left by paper tray, wipe the paper feed rollers with a clean, lint-free cloth moistened with water.
5. Wipe the feed roller on the paper tray.
6. Replace the paper tray.

INSTALLING UPGRADES

This section explains how to install optional equipment into your printer. This includes:

- > duplex (two-sided printing) unit;
[page 83](#):

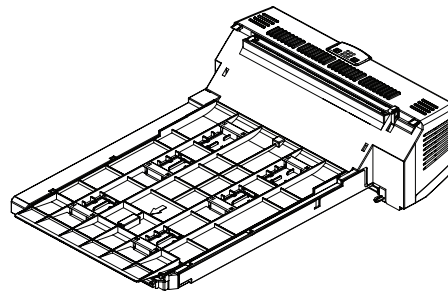

- > additional RAM memory
[page 84](#)

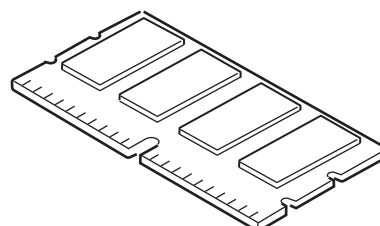

- > hard disk drive.
[page 87](#)

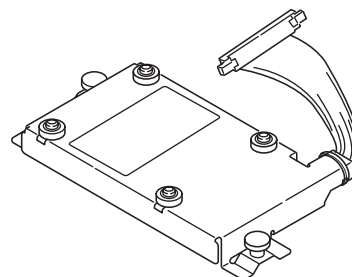

- > additional paper tray(s)
[page 89](#)

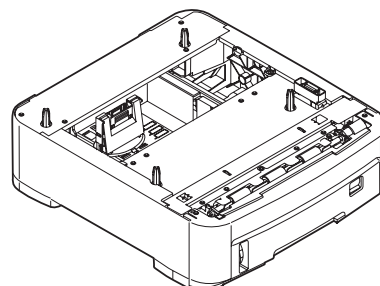

- > cabinet
[page 89](#)

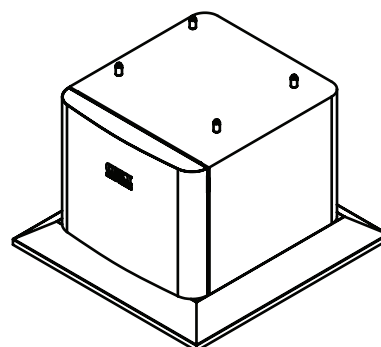

DUPLEX UNIT

The duplex unit adds the function of two-sided printing, using less paper and making large documents easier to handle. It also enables booklet printing, which uses even less paper and makes large documents even easier to handle.

The duplex unit slides straight into the rear of the printer and requires no tools to install.

1. Unpack the new unit and remove any transit material from it.
2. Switch the printer off. It is not necessary to disconnect the AC power cable.
3. Ensure that the unit is the right way up, as shown, and push it into the slot behind the rear panel. The panel will swing inwards as you push the unit into it. Push the unit all the way in until it stops and latches home.

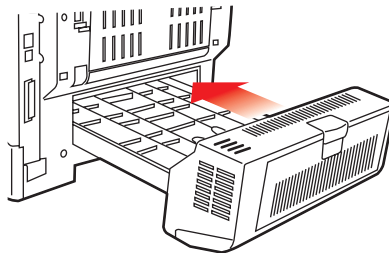

4. Switch the printer on and wait for it to warm up (about 1 minute).
5. Print a menu map as follows:
 - (a) Press the **Enter** button.
 - (b) Press the **Menu up** button, then the **Enter** button to select the Print Information menu.
 - (c) Select **Configuration** with the **Enter** button.
 - (d) Press the **Enter** button once more to execute the Configuration menu.
 - (e) When the Configuration map is printed, press **Online** to exit the menu system.
6. Examine the first page of the menu map.
7. Near the top of the page, between the two horizontal lines, you will see the current printer configuration. This list should indicate that the duplex unit is now installed.

All that remains is to adjust the printer driver to make full use of the new features (["Adjusting printer drivers" on page 90](#)).

MEMORY UPGRADE (C821 AND C830)

The basic printer model comes equipped with 256MB of main memory. This can be upgraded with an additional memory board of 256MB or 512MB, giving a maximum total memory capacity of 768MB.

1. Switch the printer off and disconnect the AC power cable.
2. Press the cover release (a) and open the printer's top cover fully.

WARNING!

If the printer has been powered on recently, the fuser will be hot. This area is clearly labelled. Do not touch.

3. Pull down the MP Tray using the depressions (b). Lift the front cover release lever and lower the front cover.

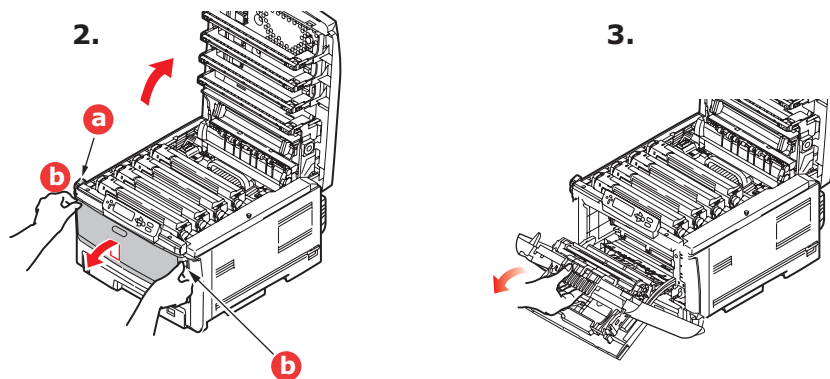

4. Remove the screw (a) securing the right-hand side cover.

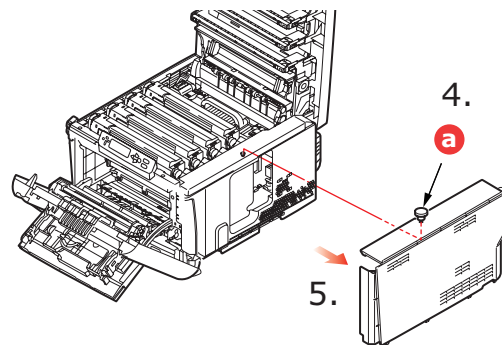

5. Lift the edge of the side cover slightly and pull the cover away from the printer at the top. Lift the cover slightly to detach it from the printer. Place it safely to one side.
6. Carefully remove the new memory board from its wrapping. Try to handle the board only by its short edges, avoiding contact with any metal parts as far as possible. In particular, avoid touching the edge connector.

- 7.** Notice that the memory board has a small cutout in the edge connector, which is closer to one end than the other.

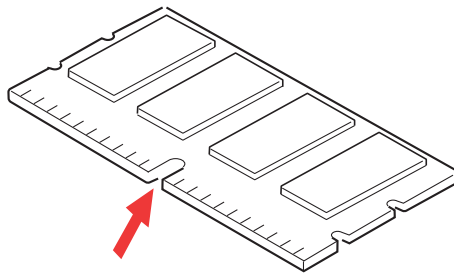

- 8.** Identify the RAM expansion slot in the printer.
- 9.** If the RAM expansion slot already contains a memory upgrade board, that board will have to be removed before you can install the new one. To remove it, proceed as follows, otherwise skip to step 10.
- (a) Grip the board firmly by its short edges and pull it out of the slot.
 - (b) Place the removed memory board in the antistatic bag which originally contained the new memory board.
- 10.** Hold the new memory board by its short edges, so that the edge connector faces in towards the RAM expansion slot, and the small cutout is closer to the rear of the printer.

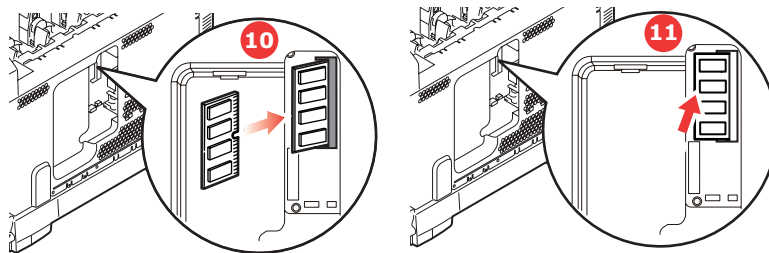

- 11.** Gently push the board into the RAM expansion slot until it latches in and will not go any further.
- 12.** Locate the three retaining clips at the bottom of the side cover into their rectangular holes near the bottom of the printer.
- 13.** Close the top of the side cover up to the printer and refit the securing screw removed in step 4.

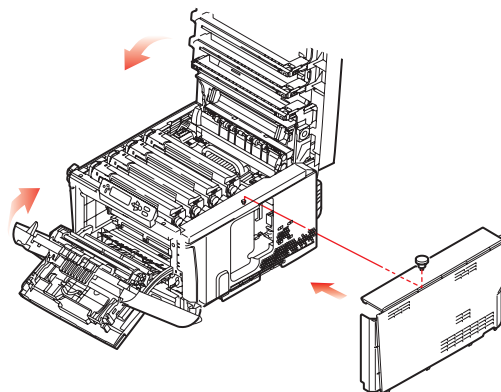

- 14.** Close the front cover, and close the top cover, pressing down firmly at each side to latch it closed.

- 15.** Reconnect the AC power cable and switch the printer on.
- 16.** When the printer is ready, print a menu map as follows:
 - (a) Press the **Enter** button.
 - (b) Press the **Menu up** button then the **Enter** button to select the Print Information menu.
 - (c) Select **Configuration** with the **Enter** button.
 - (d) Press the **Enter** button once more to execute the Configuration menu.
 - (e) When the Configuration map is printed, press **On Line** to exit the menu system.
- 17.** Examine the first page of the menu map.

Near the top of the page, between the two horizontal lines, you will see the current printer configuration. This list contains the figure for total memory size.

This should indicate the total memory now installed.

HARD DISK DRIVE (C821 AND C830)

The optional internal hard disk drive (HDD) enables collating of printed pages and can be used to store overlays and macros, fonts, and secure or proof documents waiting to be printed.

1. Switch the printer off and disconnect the AC power cable.
2. Press the cover release and open the printer's top cover fully.

WARNING!

If the printer has been powered on recently, the fuser will be hot. This area is clearly labelled. Do not touch.

3. Pull down the MP Tray using the depressions (b). Lift the front cover release lever and lower the front cover.

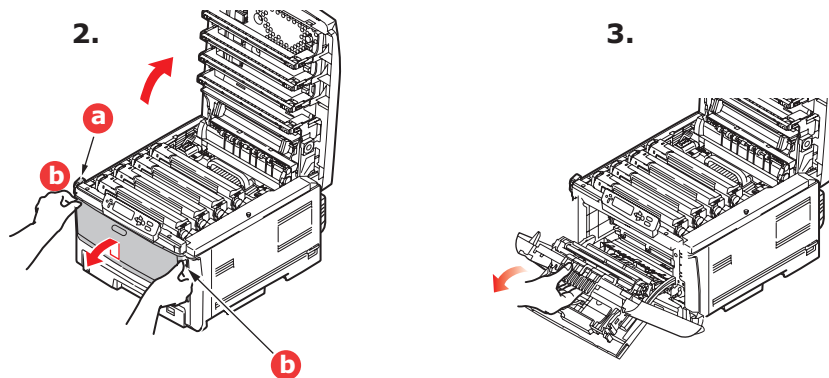

4. Remove the screw (a) securing the right-hand side cover.

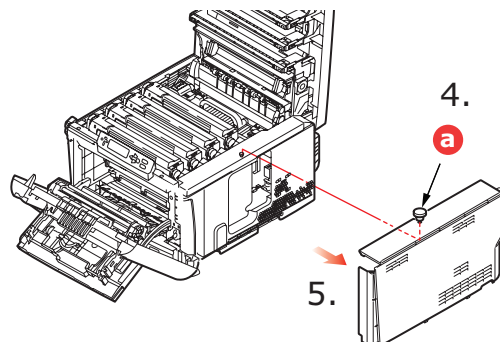

5. Lift the edge of the side cover slightly and pull the cover away from the printer at the top. Lift the cover slightly to detach it from the printer. Place it safely to one side.

6. Plug the end of the connecting cable (a) into the disk unit connector (b) in the printer.

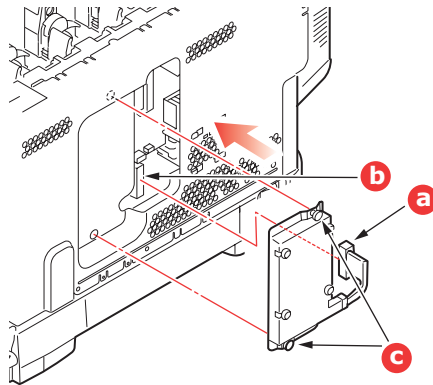

7. Tighten the two thumbscrews (c).
8. Close the top of the side cover up to the printer and refit the securing screw removed in step 4.

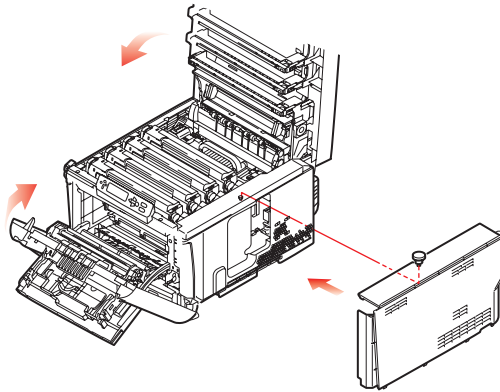

9. Close the front cover and the top cover, pressing down firmly at each side to latch it closed.
10. All that remains is to adjust the printer driver to make full use of the new features (["Adjusting printer drivers" on page 90](#)).
11. Reconnect the AC power cable and switch the printer on.
12. When the printer is ready, print a menu map as follows:
 - (a) Press the **Enter** button.
 - (b) Press the **Menu up** button then the **Enter** button to select the Print Information menu.
 - (c) Select **Configuration** with the **Enter** button.
 - (d) Press the **Enter** button once more to execute the Configuration menu.
 - (e) When the Configuration map is printed, press **On Line** to exit the menu system.
13. Examine the first page of the menu map.

Near the top of the page, between the two horizontal lines, you will see the current printer configuration. This should now indicate that the hard disk unit is installed.

ADDITIONAL PAPER TRAY(S)

1. Switch the printer off and disconnect the AC power cable.
2. Place additional paper tray(s) on desired location.

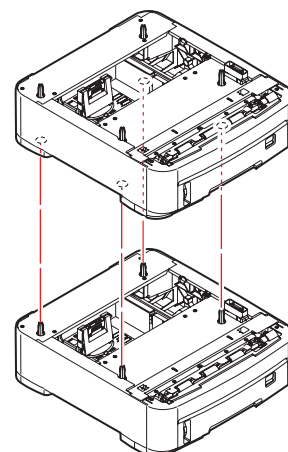

3. Observing safety rules for lifting and, using locating guides (a), place printer on top of the additional paper tray(s).

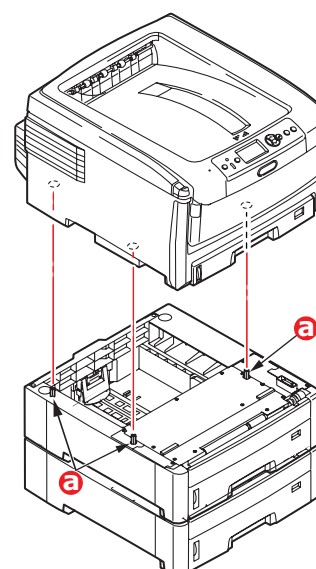

4. Re-connect the AC power cable and switch the printer ON.
All that remains is to adjust the printer driver to make full use of the new features (["Adjusting printer drivers" on page 90](#)).

STORAGE CABINET

Instructions for installing the storage cabinet are supplied with the cabinet.

ADJUSTING PRINTER DRIVERS

Once your new upgrade has been installed, you may need to update the printer driver so that the additional features are available to your applications.

Remember that if your printer is shared between users on different computers, the driver must be adjusted on each user's machine.

The illustrations shown here are for Windows XP. Other Windows versions may appear slightly different, but the principles are the same.

If you have installed a memory upgrade it is not necessary to change the printer driver, and you can ignore this section.

If you have installed a duplex unit, hard disk or paper tray(s), proceed as follows:

WINDOWS

1. Access the driver's Properties window.
 - (a) Open the Printers window (called "Printers and Faxes" in Windows XP) via the Start Menu or from the Windows Control Panel.
 - (b) Right-click the icon for this machine, and choose Properties from the pop-up menu.
2. Select the **Device Options** tab.

In the Windows XP PostScript driver the tab may be called **Device Settings**.

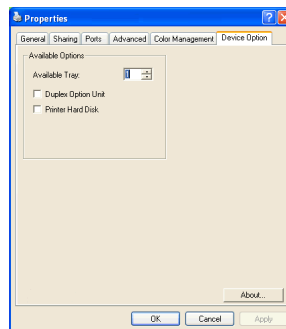

3. Set the options for any devices you have just installed.
4. Click **OK** to close the window and save your changes.

MAC OS X

If you have added additional hardware to your printer, these must be enabled in the printer driver. Additional hardware may include extra paper trays, a printer hard disk or a duplex unit.

Snow Leopard (Mac OS X 10.6) and Leopard (Mac OS X 10.5)

1. Open the Mac OS X **Print & Fax Preferences**.
2. Ensure your machine is selected.
3. Select **Options & Supplies**.
4. Select **Driver**.
5. Select all hardware options appropriate to your machine and click **OK**.

Tiger (Mac OS X 10.4)

- 1.** Open the Mac OS X **Print & Fax Preferences**.
- 2.** Ensure your machine is selected.
- 3.** Select **Printer Setup...**
- 4.** Select the menu and choose **Installable Options...**
- 5.** Select all hardware options appropriate to your machine and click **Apply Changes...**

Panther (Mac OS X 10.3)

- 1.** Open the Mac OS X **Print & Fax Preferences**.
- 2.** Select **Printing**.
- 3.** Select **Set Up Printers...**
- 4.** Ensure your machine is selected and select **Show Info...**
- 5.** Select the menu and choose **Installable Options...**
- 6.** Select all hardware options appropriate to your machine and click **Apply Changes...**

TROUBLESHOOTING

Provided that you follow the recommendations in this guide on the use of print media, and you keep the media in good condition prior to use, your printer should give years of reliable service. However, paper jams occasionally do occur, and this section explains how to clear them quickly and simply.

Jams can occur due to paper misfeeding from a paper tray or at any point on the paper path through the printer. When a jam occurs, the printer immediately stops, and the Alert LED on the Status Panel (together with the Status Monitor) informs you of the event. If printing multiple pages (or copies), do not assume that, having cleared an obvious sheet, others will not also be stopped somewhere along the path. These must also be removed in order to clear the jam fully and restore normal operation.

MAJOR PRINTER COMPONENTS AND PAPER PATH

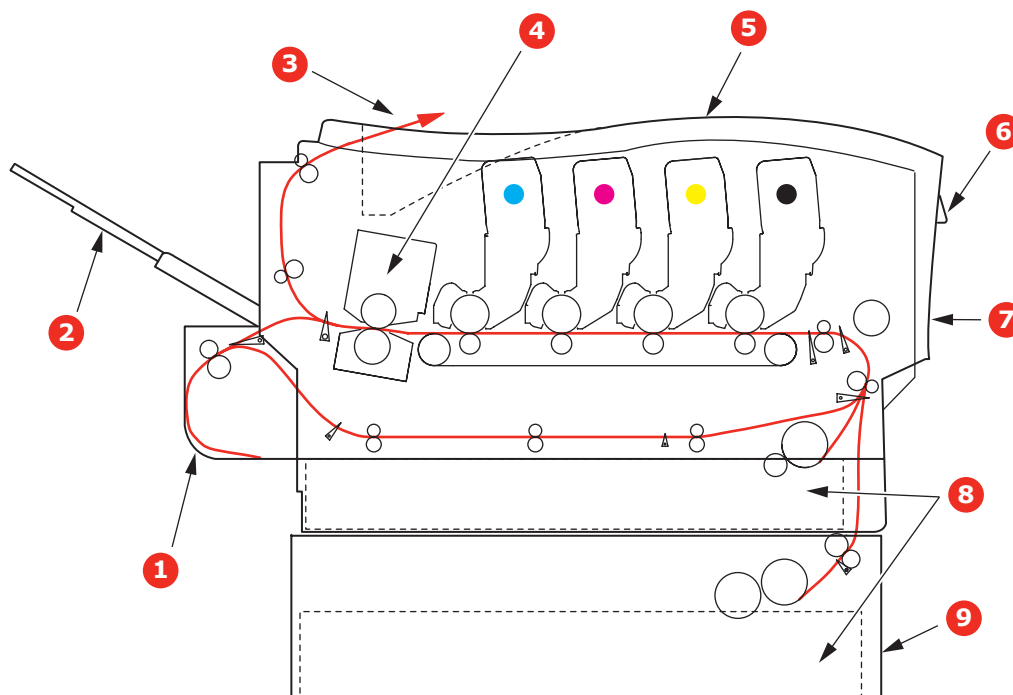

- | | |
|-----------------------------|--------------------------------------|
| 1. Duplex unit (if fitted). | 6. Operator panel. |
| 2. Face-up stacker. | 7. Front cover. |
| 3. Paper exit. | 8. Paper tray. |
| 4. Fuser unit | 9. Additional paper tray (if fitted) |
| 5. Top cover. | |

PAPER SENSOR ERROR CODES

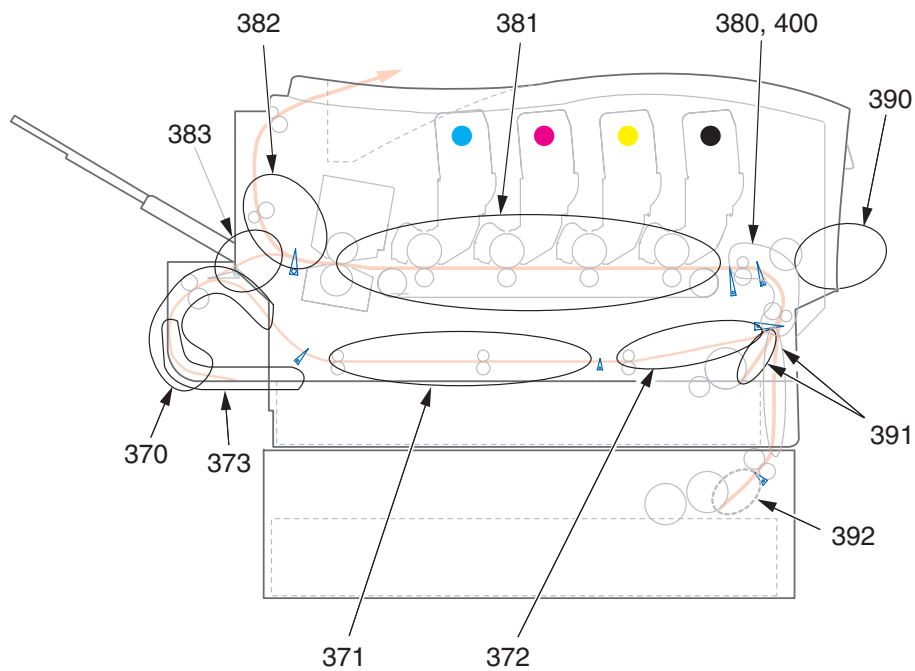

CODE #	LOCATION	CODE #	LOCATION
370	Duplex unit ^a	382	Paper exit
371	Duplex unit ^a	383	Duplex unit ^a
372	Duplex unit ^a	390	MP Tray
373	Duplex unit ^a	391	Paper Tray
380	Paper feed	392	2 nd Paper tray ^a
381	Paper path	400	Paper size

a. If fitted.

CLEARING PAPER JAMS

1. If a sheet is well advanced out of the top of the printer, simply grip it and pull gently to draw it fully out. If it does not remove easily, do not use excessive force. It can be removed from the rear later.
2. Press the cover release and open the printer's top cover fully.

WARNING!

If the printer has been powered on, the fuser will be hot. This area is clearly labelled. Do not touch.

3. Note the positions of the four toner cartridges (a) and image drums (b). It is essential that they go back in the same order.

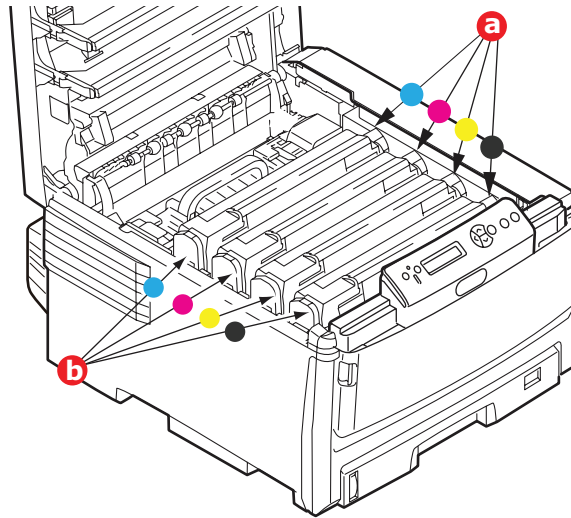

It will be necessary to remove the four image drums (b) to gain access to the paper path.

4. Holding it by its top centre, lift the image drum, complete with its toner cartridge, up and out of the printer.

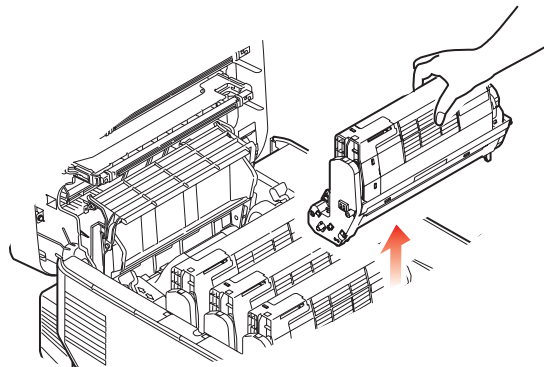

5. Put the assembly down gently onto a piece of paper to prevent toner from marking your furniture and to avoid damaging the green drum surface, and cover.

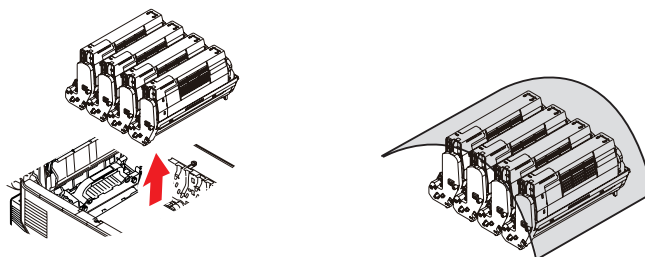

CAUTION!

The green image drum surface at the base of the Image Drum is very delicate and light sensitive. Do not touch it and do not expose it to normal room light for more than 5 minutes.

6. Repeat this removal procedure for each of the remaining image drum units.
7. Look into the printer to check whether any sheets of paper are visible on any part of the belt unit.

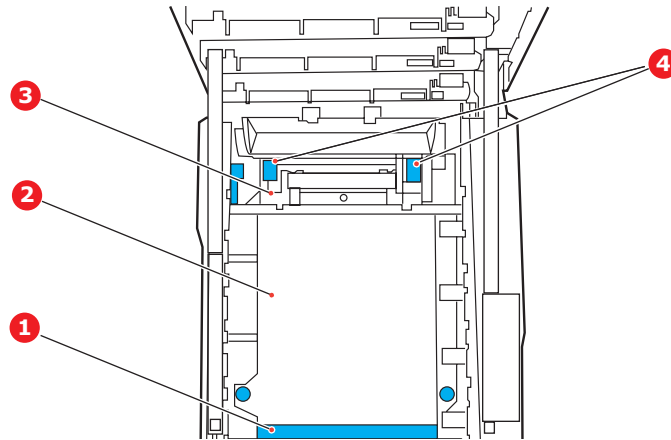

CAUTION!

Do not use any sharp or abrasive objects to separate sheets from the belt. This may damage the belt surface.

- (a) To remove a sheet with its leading edge at the front of the belt (1), carefully lift the sheet from the belt and pull it forwards into the internal drum cavity and withdraw the sheet.

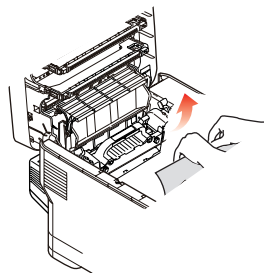

- (b) To remove a sheet from the central area of the belt (2), carefully separate the sheet from the belt surface and withdraw the sheet.
- (c) To remove a sheet just entering the fuser (3), separate the trailing edge of the sheet from the belt, lift the fuser pressure release levers (4) up and press toward the rear to release the fuser's grip on the sheet, and withdraw the sheet through the drum cavity area.

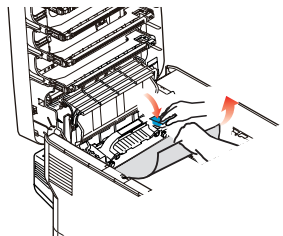

NOTE:

If the sheet is well advanced into the fuser (only a short length is still visible), do not attempt to pull it back.

- (d) To remove a sheet in the fuser; pull the retaining lever (a) towards the front of the printer to release the fuser. Withdraw the fuser unit using the handle (b). Lift the fuser pressure release levers (c) up and press toward the rear to release the fuser's grip on the sheet. Pull the trapped paper from the fuser.

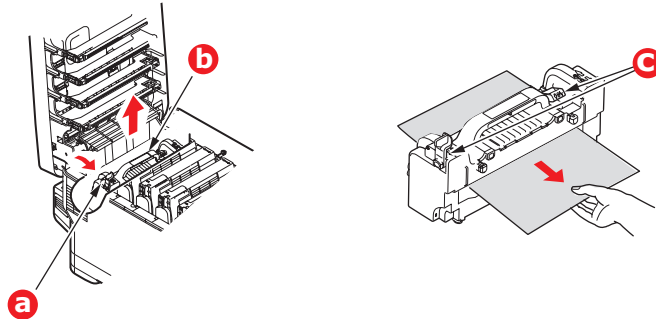

- (e) Replace fuser unit into the machine and move locking lever (a) toward the rear of the machine.

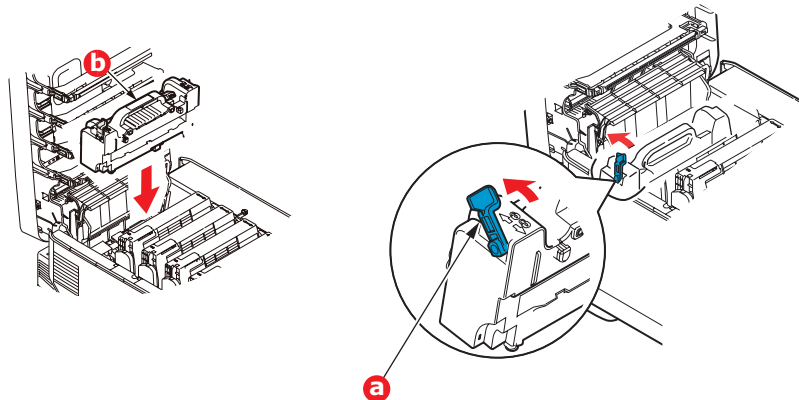

8. Starting with the cyan image drum unit nearest the fuser, replace the four image drums into the drum cavity, making sure to locate them in the correct order.

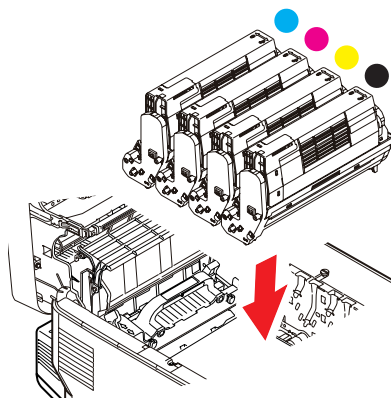

Holding the complete assembly by its top centre, lower it into place in the printer, locating the pegs at each end into their slots in the sides of the printer cavity.

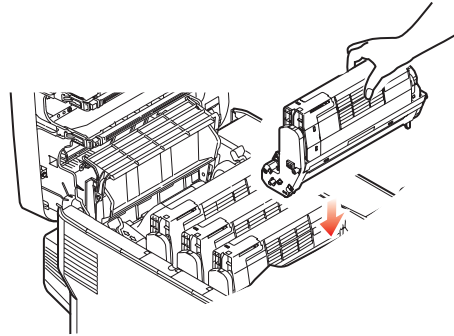

9. Lower the top cover but do not press down to latch it closed yet. This will protect the drums from excessive exposure to room lighting while you check the remaining areas for jammed sheets.
10. Open the rear exit tray (a) and check for a sheet of paper in the rear path area (b).

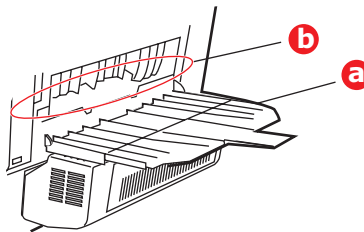

- > Pull out any sheets found in this area.
 - > If the sheet is low down in this area and difficult to remove, it is probably still gripped by the fuser. In this case raise the top cover, reach around and press down on the fuser pressure release lever.
11. If you are not using the rear exit tray, close it once any paper has been removed from this area.
 12. If a duplex unit is fitted, lift lever (a) and lower the duplex unit cover and pull out any sheets found in this area. Close the duplex unit cover

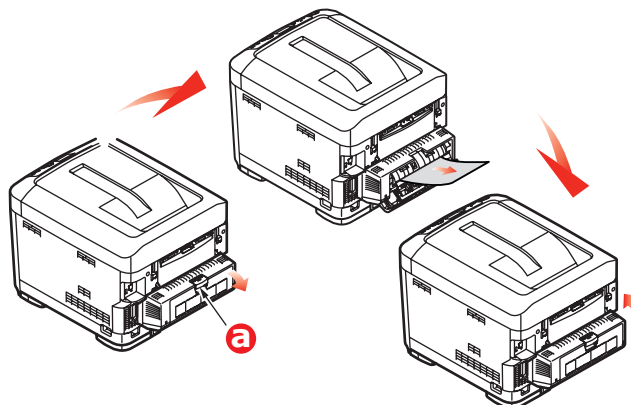

- 13.** Pull down the MP Tray using the depressions (b). Lift the front cover release lever and lower the front cover.

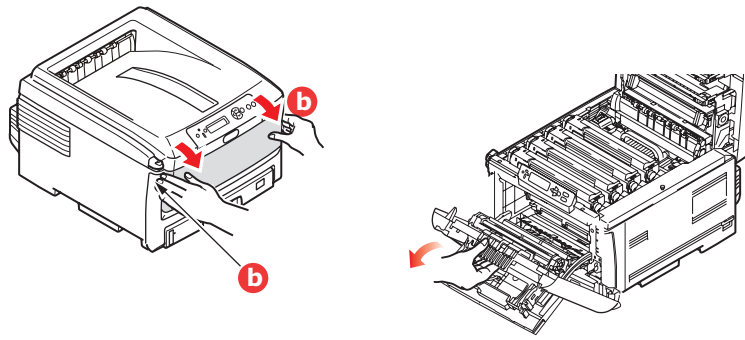

- 14.** Check inside the cover for sheets in this area and remove any that you find, then close the cover.

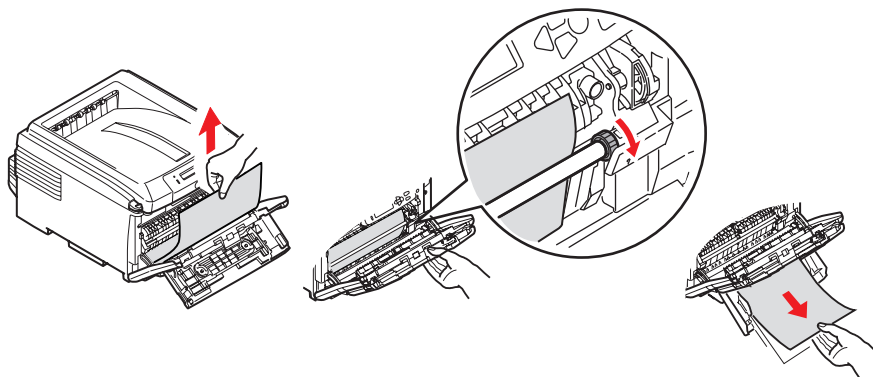

- 15.** Pull out the paper tray(s) and ensure that all paper is stacked properly, is undamaged, and that the paper guides are properly positioned against the edges of the paper stack. When satisfied, replace the tray.

- 16.** Finally, close the top cover and press down firmly so that the cover latches closed.

When the jam has been cleared, if Jam Recovery is set to ON in the System Configuration Menu, the printer will attempt to reprint any pages lost due to paper jams.

DEALING WITH UNSATISFACTORY PRINTING

SYMPTOMS	POSSIBLE CAUSES	STEPS TO TAKE
Vertical white lines can be seen on the printed page.	The LED head is dirty.	Wipe the LED head with a soft, lint-free cloth.
	The toner is low.	Open the top cover and tap the cartridge a few times to evenly distribute any remaining toner. If symptoms persist, replace the toner cartridge.
	Foreign materials may be present in the image drum.	Replace the image drum cartridge.
	Light-shielding film of the image drum cartridge is dirty.	Wipe the film with a soft, lint-free cloth.
Printed images are fading vertically.	The LED head is dirty.	Wipe the LED head with a soft, lint-free cloth.
	The toner is low.	Open the top cover and tap the cartridge a few times to evenly distribute any remaining toner. If symptoms persist, replace the toner cartridge.
	The paper is not suitable for the printer unit.	Use recommended paper.
Printing is light.	The toner cartridge is not properly seated.	Reinstall the toner cartridge.
	The toner is low.	Open the top cover and tap the cartridge a few times to evenly distribute any remaining toner. If symptoms persist, replace the toner cartridge.
	The paper is moist.	Use paper stored in proper temperature and humidity conditions.
	The paper is not suitable for the printer unit.	Use recommended paper.
	Thickness and type of paper are inappropriate.	Set the correct value of media type and media weight in the Media menu or set one value thicker for media weight.
	Recycled paper is being used.	Set one value thicker for media weight in the Media menu.
Partially faded images. White spots and lines appear in solid printing.	Paper is moist or dry.	Use paper stored in proper temperature and humidity conditions.
Vertical lines appear.	The image drum cartridge is damaged.	Replace the image drum cartridge.
	The toner is low.	Open the top cover and tap the cartridge a few times to evenly distribute any remaining toner. If symptoms persist, replace the toner cartridge.

SYMPTOMS	POSSIBLE CAUSES	STEPS TO TAKE
Horizontal Lines and spots appear periodically.	When the interval is about 94mm (4in), the image drum (the green tube) is damaged or dirty.	Wipe it lightly with a soft cloth. Replace the image drum cartridge when it is damaged.
	When the interval is about 30mm (1.2in), there may be foreign particles in the image drum cartridge.	Open/close the top cover, and print again.
	When the interval is about 86mm (3.4in), the fuser unit is damaged.	Replace the fuser unit.
	The image drum cartridge has been exposed to light.	Replace the image drum cartridge if the problem is not resolved.
White area of paper is lightly stained.	Paper contains static.	Use paper stored in proper temperature and humidity conditions.
	Too thick paper is used.	Use thinner paper.
	The toner is low.	Open the top cover and tap the cartridge a few times to evenly distribute any remaining toner. If symptoms persist, replace the toner cartridge.
Periphery of the letters is smudged.	The LED head is dirty.	Wipe the LED head with a soft, lint-free cloth.
Toner comes off when it is rubbed.	The thickness and type of the paper are incorrectly set.	Set the correct value of media type and media weight in the Media menu or set one value lighter for media weight.
	Recycled paper is used.	Set one value thicker for media weight in the Media menu.
Glossiness is not uniform.	The thickness and type of the paper are incorrectly set.	Set the correct value of media type and media weight in the Media menu or set one value lighter for media weight.

SPECIFICATIONS

C801 - N34240B

C810 - N34240B

C821 - N34241B

C830 - N34241B

ITEM	SPECIFICATION
Dimensions	485 x 579 x 345mm (W x D x H) without Duplex unit
Weight	36Kg approx. (without Duplex unit)
Power supply	220 to 240VAC @ 50/60 Hz ± 2%
Power consumption	Operating: <1350W peak; <570 W av. (25°C) Idle: 200 W typical (25°C) Power saving ^a : <15W (C801/C810) <17W (C821/C830)
Operating environment	Operating 10 to 32 °C/20 to 80% RH (optimum 25 °C wet, 2 °C dry) Off: 0 to 43 °C/10 to 90% RH (optimum 26.8 °C wet, 2 °C dry)
Print environment	30 to 73% RH @ 10 °C; 30 to 54% RH @ 32 °C 10 to 32 °C @ 30% RH; 10 to 27 °C @ 80% RH Colour 17 to 27 °C @ 50 to 0% RH
Noise Levels	Operating: Mono/Colour - less than 54dBa Standby Mode: less than 37dBa Power Saving Mode: Background level

- a. To comply with the requirements of Energy Star, when no data is present for a set period of time, the printer goes into a power-saving mode. The printer has a "wake-up" feature which, when initiated from a host device or the operator panel, will revert the printer to its "running" mode.

NOTE

This device is not intended for use at visual display workplaces - in compliance with the German regulation BildscharbV.

INDEX

B

- Belt
 - how to replace 76
 - life remaining..... 45

C

- Cleaning the feed rollers 81
- Cleaning the LED head 80
- Cleaning the unit casing..... 80
- Colour
 - adjusting..... 42

D

- Duplex
 - how to install 83
 - paper size and weight
 - limits 13

E

- Envelopes
 - loading 16

F

- Fuser
 - how to replace 78
 - life remaining..... 45

H

- Hard disk drive
 - how to install 87
- How to change the settings -
Administrator 38

I

- Image drum
 - current usage state 45
 - how to replace 73

L

- Labels
 - recommended types 11

M

- Major printer components and
paper path 92
- Menu functions
 - C801 and C810 37
 - C821 and C830 48
- Menu functions - C801 and C810
 - Administrator (Boot)
Menu 45
 - Changing the settings -
Administrator 38
 - Changing the settings -
User 37
 - Colour menu 42
 - Information menu 39
 - Maintenance menu 44
 - Media menu 40
 - Network menu 43
 - Print menu 39
 - Print Statistics Menu 47
 - Shutdown Menu 39
 - System configuration
menu 42
 - Usage menu 44
 - USB Menu 43

Menu functions - C821 and C830

- Admin Setup 56
- Administrator (Boot) Menu66
 - Language Setup 68
 - Parallel Setup 66
 - Power Setup 68
 - Print Statistics Menu ... 69
 - Security Setup 67
 - Storage Setup 68
 - Storage System 67
 - USB Setup 66
- Calibration 65
- Changing the settings -
Administrator 49
- Changing the settings -
User 49
- Configuration Menu 50
- Menu 53
- Menus 53
- Print information menu 51
- Print secure Job 52
- Shutdown menu 55

Menus

- Colour menu 42
 - how to use 37, 48
 - Information menu 39
 - Maintenance menu 44
 - Media menu 40
 - menu map 39
 - Network menu 43
 - Print menu 39
 - resetting 44
 - System configuration
menu 42
 - Usage menu 44
 - USB menu 43
- ## Multi purpose tray
- how to use 16
 - paper metrics 12

N

- Network addresses
 - setting 43
- Network protocols
 - enabling or disabling 43

O

- Operator panel
 - C801 and C810 37
 - C821 and C830 48

P

- Paper
 - jam clearing 92
 - jam, error codes 93
 - loading cassette trays 14
 - loading letterhead 14
 - recommended types 11
 - supported sheet sizes 12
 - weights and sizes 40
- Power saving
 - delay time 42
 - enabling or disabling 44
- Print order
 - face down stacker 15
 - face up stacker 15
- Print quality
 - adjusting 44
- Printer overview 9

- Problem checklist
 - unsatisfactory printing 99

S

- Switching off correctly 55

T

- Toner
 - current usage state 45
 - how to replace 70
- Transparencies
 - recommended types 11

U

- Upgrades
 - memory 84

OKI CONTACT DETAILS

Oki Systems (UK) Limited

550 Dundee Road
Slough Trading Estate
Slough, SL1 4LE

Tel: 44 (0) 1753 819819

Fax: 44 (0) 1753 819899

<http://www.oki.co.uk>

Oki Systems Ireland Limited

The Square Industrial Complex
Tallaght, Dublin 24, Ireland

Tel: +353 1 4049590

Fax: +353 1 4049591

<http://www.oki.ie>

Technical Support:

Tel: +353 1 4049570

Fax: +353 1 4049555

E-mail: tech.support@oki.ie

OKI Systems (Ireland) Ltd.

(Northern Ireland)
40 Sydenham Park
Belfast, BT4 1PW

Tel: +44 (0)28 90 20 1110

<http://www.oki.ie>

Technical Support:

Tel: +44 (0)28 90 221919

E-mail: tech.support@oki.ie

OKI EUROPE LIMITED

Blays House
Wick Road
Egham
Surrey TW20 0HJ
United Kingdom

Tel: +44 (0) 208 219 2190

Fax: +44 (0) 208 219 2199

WWW.OKIPRINTINGSOLUTIONS.COM

