

C9650n/C9650dn/C9650hdn

Handy Reference
Guide de référence pratique
Referencia Rápida
Guia de referência rápida

Contents

Replacement Supplies	5	Paper (Media) Jams	20
Purchasing Information	5	Tray Side Cover	21
Part Numbers	5	Printer Side Cover	22
Using the Printer Menu	7	Printer Top Cover	23
Changing Settings	7	Duplexer	27
Menu Summary	8	Maintenance	30
Changing Paper (Media)		Cleaning the LED Heads	30
Settings	9	Cleaning the Paper Tray	
Changing Default Settings	10	Feed Rollers	32
Print Media	11	Reports	36
Paper Weight	11	Printing Reports	36
Loading Trays 1–5	13	Error Messages	37
Loading the MP Tray	14	Help Button	37
Exit Paths	16	Service Information	38
Face Down (Top Exit)	16		
Face Up (Side Exit)	17		
Recommended Media	18		
Paper	18		
Card Stock	18		
Labels	19		
Envelopes	19		
Transparencies	19		

Table des matières

Fournitures de remplacement 39

- Renseignements concernant
- les achats39
- Numéros de pièce40

Utilisation du menu d'impression 41

- Modifier le paramètres41
- Sommaire du menu42
- Modification des paramètres
- papier43
- Modification des paramètres
- par défaut44

Support d'impression 45

- Grammage des supports45
- Chargement des plateaux
- 1-547
- Chargement du bac
- multifonction48

Sorties 50

- Face vers le bas
- (sortie du dessus)50
- Face vers le haut
- (sortie latérale)51

Supports recommandés .. 52

- Papier52
- Cartonné52
- Étiquettes53
- Enveloppes53
- Transparents53

Bourrages papier (support) 54

- Couvercle latéral de bac55
- Couvercle latéral
- de l'imprimante56
- Capot supérieur
- de l'imprimante57
- Unité recto verso61

Entretien 64

- Nettoyage de la matrice
- à DEL64
- Nettoyage des rouleaux d'alimentation du plateau de papier66

Rapports 70

- Impression de Rapports70

Messages d'erreur 71

- le bouton Help71

Information de service 72

Contenido

Suministros de repuesto .. 73

Información de compras73

Número de partes73

Cómo utilizar el menú de la impresora 75

Cambiar configuración75

Resumen del menú76

Cómo cambiar la configuración del papel77

Cambio de los valores predeterminados78

Medios de impresión 79

Gramaje del papel79

Bandejas de papel 1-581

Cómo cargar papel en la Bandeja multiuso82

Rutas de salida 84

Cara Abajo (Salida superior)84

Cara Arriba (Salida lateral)85

Medios de impresión recomendados 86

Papel86

Cartulina86

Etiquetas87

Sobres87

Transparencias87

Atascos de papel (Medios) 88

Tapa lateral de la bandeja89

Tapa lateral de la impresora90

Tapa superior de la impresora91

Unidad duplex95

Mantenimiento 98

Limpieza de la Cabezales LED98

Limpieza de los rodillos de alimentación de las bandejas de papel100

Informes104

Cómo imprimir los informes ...104

Mensajes de error105

el tecla Help105

Información sobre los Servicios de apoyo al cliente106

Sumário

Suprimentos de reposição	107
Informações para compra	107
Números dos componentes	107
Utilização dos menus da impressora	109
Altere as configurações	109
Resumo dos menus	110
Alteração das configurações do papel (mídia)	111
Alteração das configurações padrão	112
Mídia de impressão	113
Gramatura do papel	113
Carregamento das bandejas 1 a 5	115
Carregamento da bandeja multifuncional	116
Percursos de saída	118
Face para baixo (Saída superior)	118
Face de impressão para cima (Saída lateral)	119
Mídia de impressão recomendada	120
Papel	120
Cartão	120
Etiquetas	121
Envelopes	121
Transparências	121
Atolamentos de mídia	122
Tampa lateral da bandeja	123
Tampa lateral da impressora ...	124
Tampa superior da impressora	125
Unidade duplex	129
Manutenção	132
Limpeza do pente de LEDs	132
Limpeza dos roletes de alimentação da bandeja para papel	134
Relatórios	138
Impressão de relatórios	138
Mensagens de erro	139
Botão Help	139
Informações sobre assistência técnica	140

Replacement Supplies

Purchasing Information, Part Numbers

Where to Purchase

- Consult the dealer where you purchased your printer
- Consult an Oki Data Authorized Sales or Service Dealer. For the nearest dealer, call 1-800-654-3282.
- *U.S., Puerto Rico, Guam, U.S. Virgin Islands only:* Order on the Internet at www.okiprintingsolutions.com
- *U.S. only:* Order toll-free at 1-800-654-3282, using VISA[®], MasterCard[®] or AMEX[®].
- Check office supply catalogs.

Use Oki Supply Manager

- Calculates your usage based on information you provide.
- Sends you an E-mail when it's time to reorder.

To register, go to

www.okiprintingsolutions.com

Part Numbers

Important!

Consumables designated "C9000 Series" do not work with these printers. Use only Type C7 Toner Cartridges and Image Drums having the part numbers listed below.

Toner Cartridges, Type C7

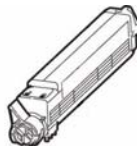

Color	OKI Part #
Black	42918984
Cyan	42918983
Magenta	42918982
Yellow	42918981

Replacement Supplies

Part Numbers (cont.)

Image Drums, Type C7

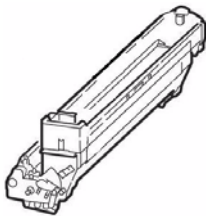

Color	OKI Part #
Black	42918168
Cyan	42918167
Magenta	42918166
Yellow.....	42918165

Other Items

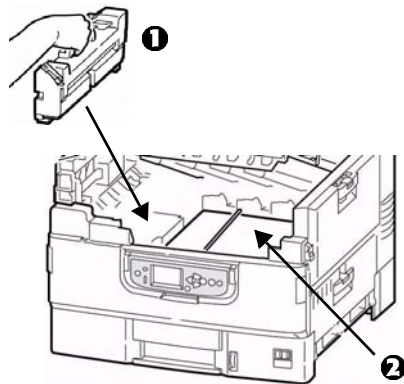

Item	OKI Part #
Fuser (1)	42931701, 120V
.....	42931702, 230V
Transfer Belt (2)	42931601
Toner Waste Bottle	42869401

Using the Printer Menu

Changing Settings

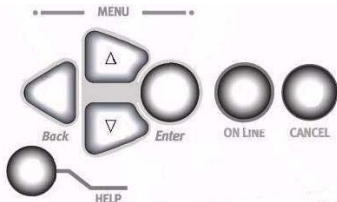
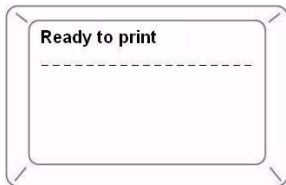

1. Press **Enter**.

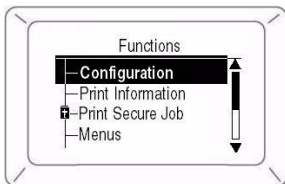

2. Use the ∇ key to scroll down to the Function you wish to change.
3. Press **Enter**.
4. Continue to use the ∇ and **Enter** keys to drill down to the item you wish to change.

5. Use the ∇ key to move down to the setting you wish to engage.
6. Press **Enter**.
An asterisk appears next to the setting.
7. Press **ON LINE** to exit the Menu mode.

For more information, see the on-line User's Guide on the Documentation CD provided with your printer or at <http://my.okidata.com>.

Using the Printer Menu

Menu Summary

– Configuration

- Page Count, Supplies Life
- Network and System Settings, etc.

– Print Information

- Printer & Network Configurations
- Print Demo Page
- Lists, etc.

– Print Secure Job

(Password Protected)

Appears only if the Hard Disk Drive (HDD) (optional on Models C9650n and C9650dn) is installed.

- Print out confidential documents downloaded to the HDD

– Menus

- Set the size, weight and type of media for the various feed trays

– Admin Setup

(Password Protected)

- Various Network Setups
- Print Setup
- PS and PCL Setups
- IBM and Epson Setups
- Color Setup
- Memory and Flash Memory Setups
- HDD and System Setups
- Reset/Save/Restore Settings

– Calibration

- Density adjustments
- Registration
- Color tuning

– Print Statistics

(Password Protected)

Using the Printer Menu

Changing Paper (Media) Settings

Why Change?

Wrong media settings can cause:

- poor quality printing
- flaking
- *damage to the printer*

Media Weight

The default media weight setting for all trays is AUTO.

Individual Print Jobs

If you are using special media for only one print job, you can adjust the media settings *in the driver*. Load the media in the appropriate tray (usually the MP tray). In your application, click File → Print and adjust the media settings as necessary.

All Print Jobs (Defaults)

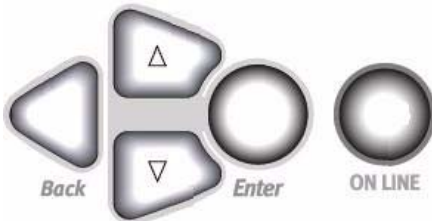

1. Press **Enter**.
2. ▽ key → Menu. Press **Enter**.
3. With Tray Configuration highlighted, press **Enter**.
4. ▽ key → tray to be configured. Press **Enter**.
5. Use the ▽ and **Enter** keys to scroll through the submenus and to make your setting changes.
6. Press **ON LINE** to exit the Menu Mode.

Using the Printer Menu

Changing Default Settings

Reset to Factory Defaults

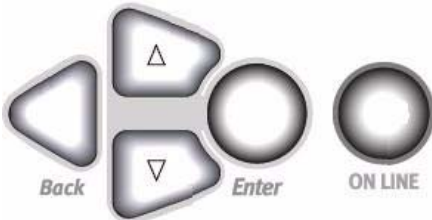

1. Press **Enter**.
2. Use the ∇ key to scroll down to Admin Setup. Press **Enter**.
Enter Password appears
3. Use the Δ and ∇ keys to set the first digit in the password. Press **Enter**.
Note: The default Password is aaaaaa.
4. Repeat the previous step until all four digits of the password are entered.
5. Press **Enter**.
6. ∇ key \rightarrow Settings. Press **Enter**.
7. Highlight Reset Settings. Press **Enter**.
8. Press **Enter**.
The printer resets and goes back to the Ready to Print state.

Print Media

Paper Weight

Note: For information on paper parameters as they relate to input trays and output areas see the on-line User's Guide on the Documentation CD provided with your printer or at <http://my.okidata.com>.

Note: Select the appropriate settings in either the printer menu or in the printer driver.

Note: Printer *driver* settings override printer *menu* settings.

US Bond

Setting	US Bond (metric)
Auto (<i>default</i>)	17 to 57-lb. (64 to 216 g/m)
Light	17-lb. (64 g/m)
Medium Light	18 to 19-b. (68 to 71 g/m)
Medium	20 to 24-lb. (75 to 90 g/m)
Medium Heavy	25 to 28-lb. (94 to 105 g/m)
Heavy	29 to 34-lb. (109 to 128 g/m)
Ultra heavy 1	35 to 50-lb. (132 to 188 g/m)
Ultra heavy 2	51 to 58-lb. (192 to 218 g/m)
Ultra heavy 3 [<i>MP Tray only</i>]	59 to 80-lb. (222 to 301 g/m)

Print Media

Paper Weight (cont.)

Index

Setting	Index (metric)
Auto (<i>default</i>)	35 to 118.6-lb. (64 to 216 g/m)
Light	35-lb. (64 g/m)
Medium Light	37 to 40-lb. (68 to 71 g/m)
Medium	42 to 50-lb. (75 to 90 g/m)
Medium Heavy	52 to 56-lb. (94 to 105 g/m)
Heavy	60 to 71-lb. (109 to 128 g/m)
Ultra heavy 1	73 to 104-lb. (132 to 188 g/m)
Ultra heavy 2	106 to 141-lb. (192 to 218 g/m)
Ultra heavy 3 [<i>MP Tray only</i>]	123 to 166-lb. (222 to 301 g/m)

Note: To determine if a paper weight is US Bond or Index, check the metric equivalent.

Example: 35 lb. *US Bond* = 132 g/m

35 lb. *Index* = 64 g/m

For more information, go to www.paper-paper.com/weight.html

Print Media

Loading Trays 1–5

Loading Media in Trays 1-5

For more information, see the on-line User's Guide on the Documentation CD provided with your printer or at <http://my.okidata.com>.

1.

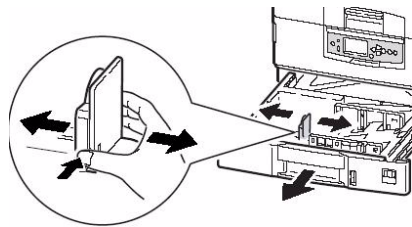

2.

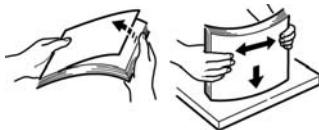

3. Print side *down*:

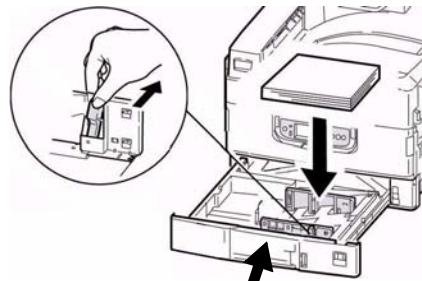

Note: For Letterhead stationery:

Long edge feed—face down, top toward the back of the printer.

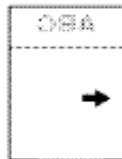

Short edge feed—face down, top to the right:



Print Media

Loading the MP Tray

Loading Media, MP Tray

For more information, see the on-line User's Guide on the Documentation CD provided with your printer or at <http://my.okidata.com>.

1.

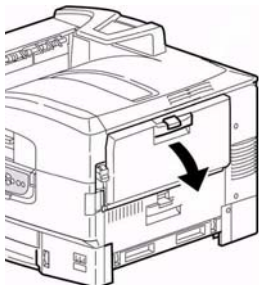

2.

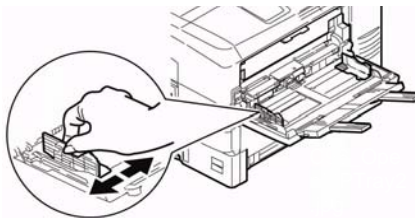

3.

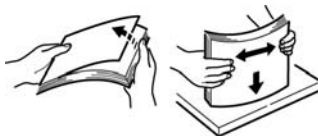

4. **Print side up.**

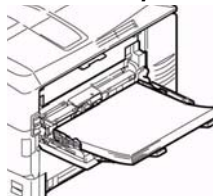

Print Media

Loading the MP Tray (cont.)

Note: Letterhead Stationery (Letter, A4 or B5):

Long edge feed—aim the top toward the back of the printer:

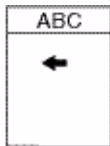

Short edge feed—aim the top into the printer:

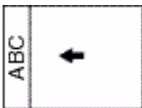

Note: Transparencies & Labels:

- Print side *up*.
- Default = long edge feed.

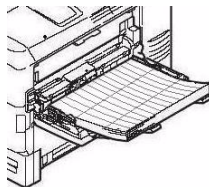

Envelopes:

- Flap side *down*, aimed into the printer:

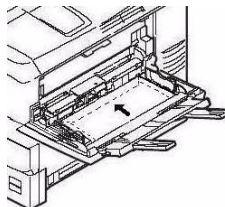

Exit Paths

Face Down (Top Exit)

This is the tray that is normally used.

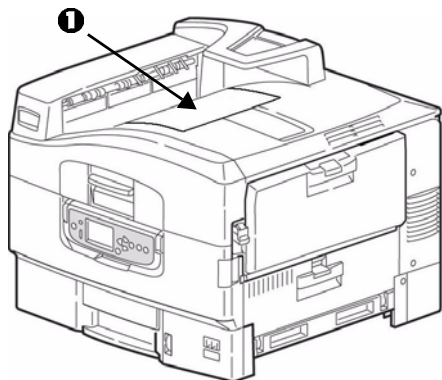

The tray holds up to 500 sheets of 20-lb. (75 g/m) paper.

The Face-Up exit tray (see the next page) must be used for special media or for heavy papers.

Exit Paths

Face Up (Side Exit)

The side (face-up) exit tray provides a straight-through print path. Use the straight-through path when printing labels, heavy card stock, transparencies, or when printing from the MP Tray. It holds up to 200 sheets of 20-lb. (75 g/m) paper.

Opening the Face-Up Exit Tray

1.

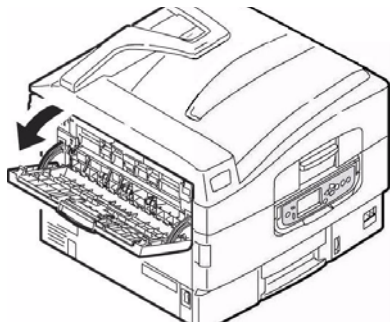

2.

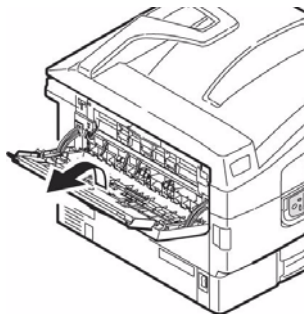

3.



Recommended Media

Paper, Card Stock

Media Type	Recommended
Paper	<p>Letter:</p> <ul style="list-style-type: none">• OKI® 52208001 Bright White, 32-lb. US Bond• HammerMill® Laser Print Radiant, White, 24-lb. US Bond• Xerox® 4024, 20-lb. US Bond <p>Tabloid/Tabloid Extra:</p> <ul style="list-style-type: none">• Oki 52206102, 52206103 Bright White, 32-lb. US Bond• HammerMill Laser Print Radiant, White, 24-lb. US Bond <p>Banners:</p> <ul style="list-style-type: none">• Oki 52207901, 8.5" x 35.4", 32-lb. US Bond, 25 sheets• Oki 52206002, 8.5" x 35.4", 32-lb. US Bond, 100 sheets• Oki 52206001, 12.9" x 35.4", 32-lb. US Bond, 100 sheets
Thick (Cards)	<p>Letter:</p> <ul style="list-style-type: none">• Oki 52205601 series Card Stock• Wausau Exact Index: 49108 (90-lb.) or 49508 (110-lb.) <p><i>To prevent damage to the printer, it is very important to check the printer's media settings before printing on thick paper.</i></p>

Recommended Media

Labels, Envelopes, Transparencies

Media Type	Recommended
Labels	<p>Letter: Avery® 5161</p> <p>A4: Avery 7162, 7664, 7666</p> <p><i>Use labels designated for laser printers. Labels must cover the entire carrier sheet.</i></p>
Envelopes	<p>COM-10: Oki 52206301, 52206302</p> <p><i>For the best print results, use only the recommended envelopes. Never use envelopes with metal clasps, snaps, windows, or V-flap seals.</i></p>
Transparencies	<p>Letter:</p> <ul style="list-style-type: none">• Oki 52205701• 3M® CG3720 <p><i>For the best print results, use only the recommended transparencies. Never use office transparencies designed for use by hand with marker pens. These will melt in the fuser and cause damage.</i></p>

Paper (Media) Jams In General

If you are experiencing frequent paper jams, check the following items.

- Is the printer level?
- Is the media you are using within specification? Media that is too light or too heavy will often cause jams.
- Are the settings (printer and driver) appropriate for the media being used?
- Do not use creased or curled media.
- Remove the media from the tray. Fan and align the stack. Replace the media.

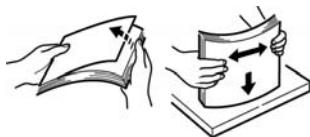

- Envelopes are jamming. Make sure the stack is properly aligned. Load envelopes flap down, top edge toward the printer.

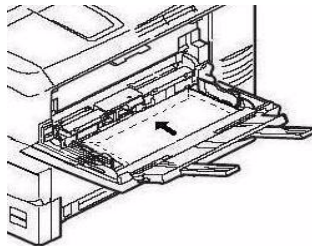

- Clean the feed rollers (see page 32).

Note:

For more information, see the on-line User's Guide on the Documentation CD provided with your printer or at <http://my.okidata.com>.

Paper (Media) Jams

Tray Side Cover

Tray Side Cover

1.

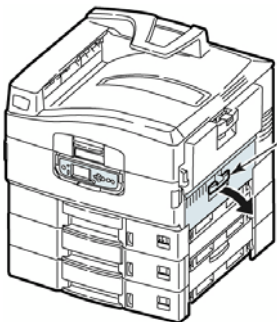

Squeeze
the catch
and open
cover

2.

Hold the tab, turn
paper guide outward

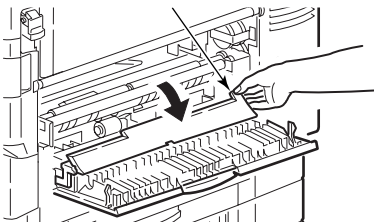

3.

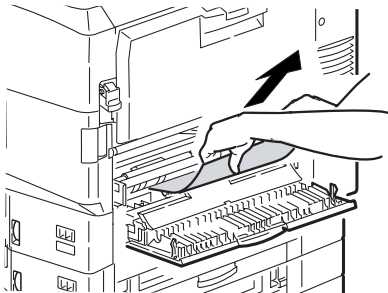

4.

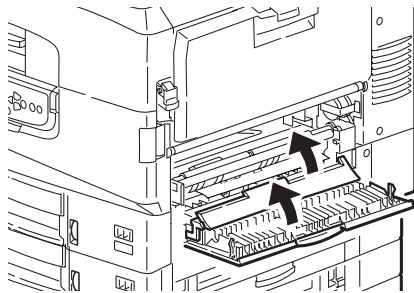

Paper (Media) Jams Printer Side Cover

Printer Side Cover

1.

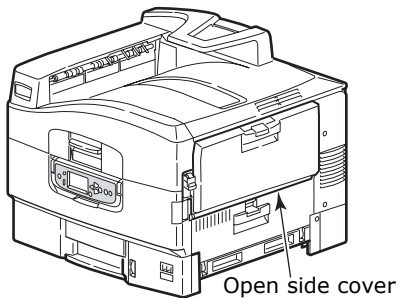

2.

Pull release lever and open side cover

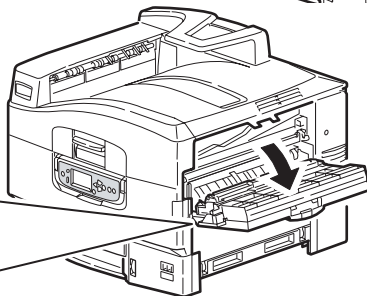
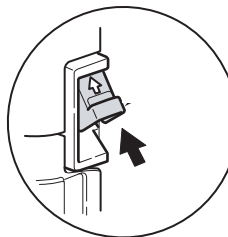

3.

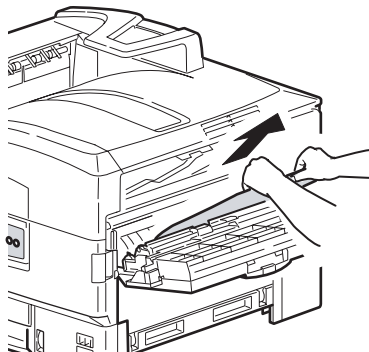

4.

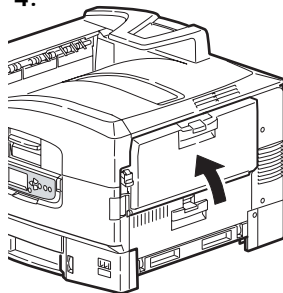

Paper (Media) Jams Printer Top Cover

Printer Top Cover

1. Squeeze top cover handle

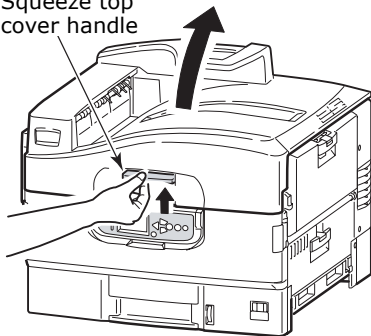

WARNING!

Be careful not to touch the fuser unit which is hot after printing.

- 2.

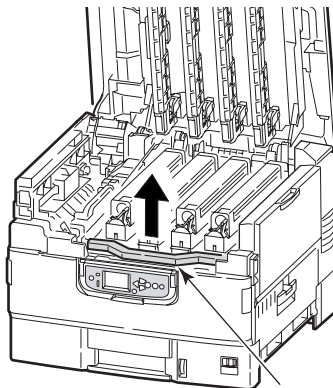

Squeeze basket handle and raise drum basket

- 3.

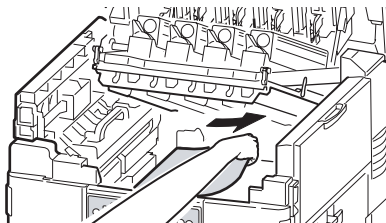

Paper (Media) Jams Printer Top Cover (cont.)

WARNING!

Be careful not to touch the fuser unit which may be hot after printing. If the fuser unit is hot, wait until it cools before attempting to remove any jammed paper.

4.

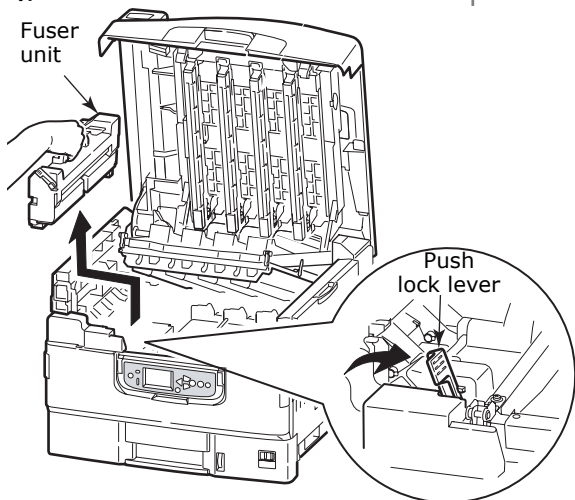

5.

Pull up jam release levers to release paper

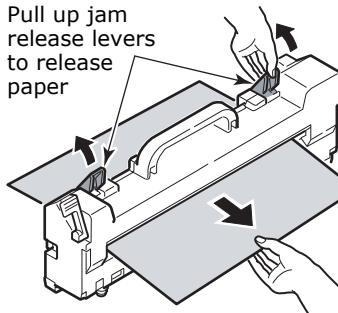

Paper (Media) Jams Printer Top Cover (cont.)

6.

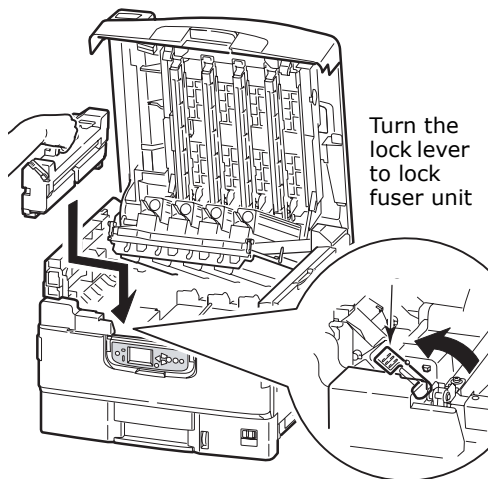

7.

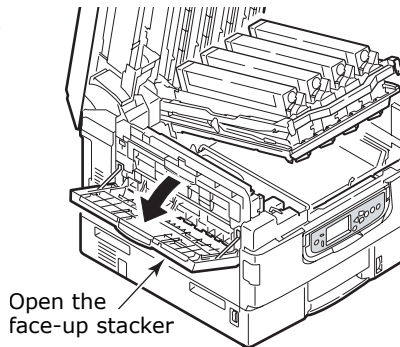

8.

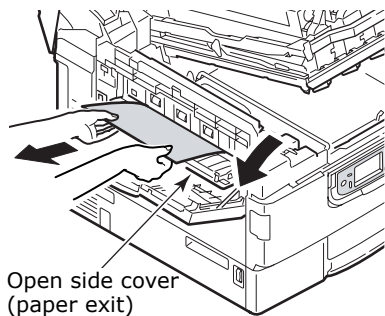

Paper (Media) Jams Printer Top Cover (cont.)

9.

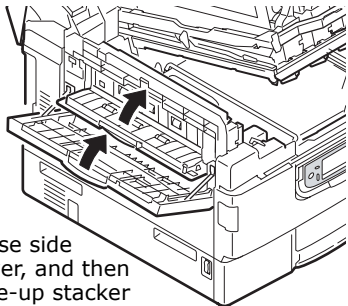

Close side
cover, and then
face-up stacker

10.

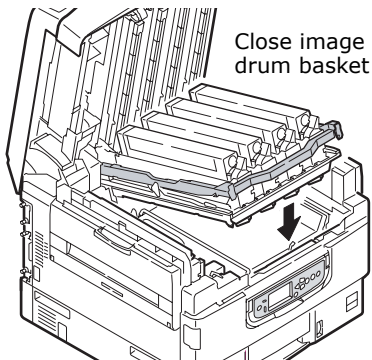

Close image
drum basket

11.

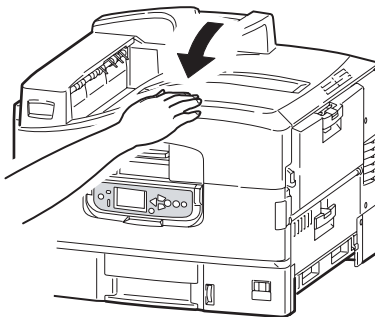

Paper (Media) Jams

Duplexer

Duplexer

1.

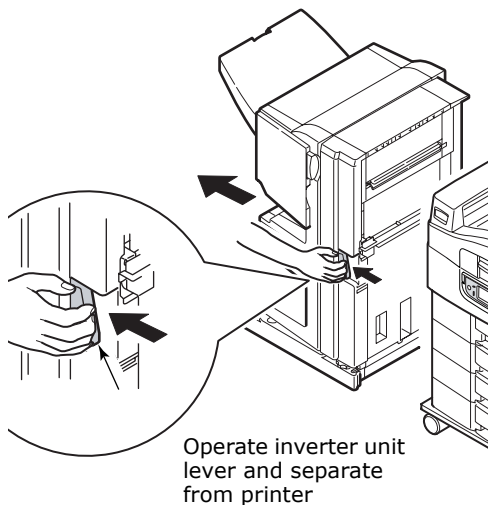

2.

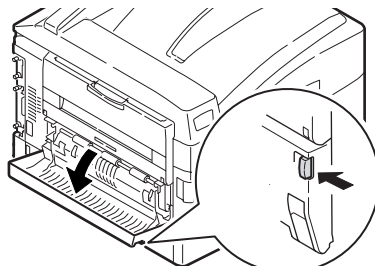

3.

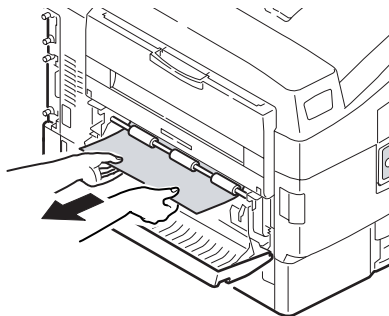

Paper (Media) Jams Duplexer (cont.)

4.

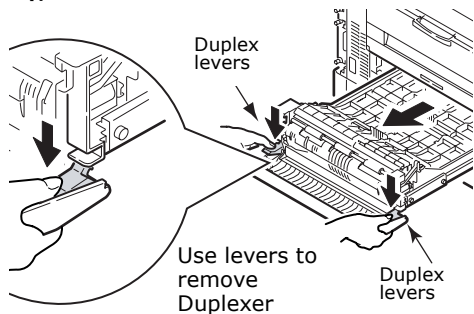

5.

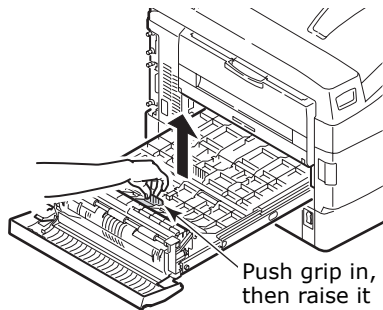

6.

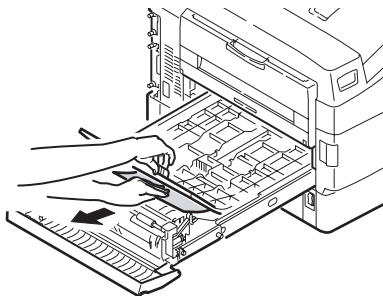

7.

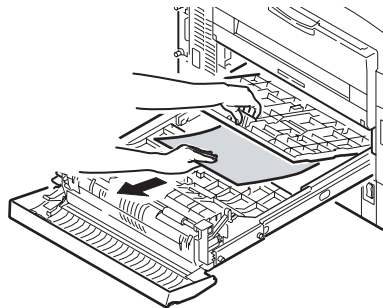

Paper (Media) Jams Duplexer (cont.)

8.

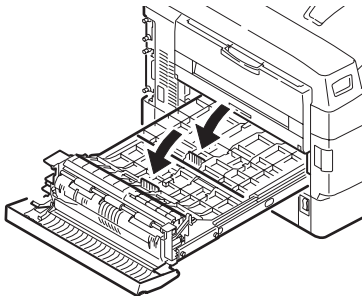

9.

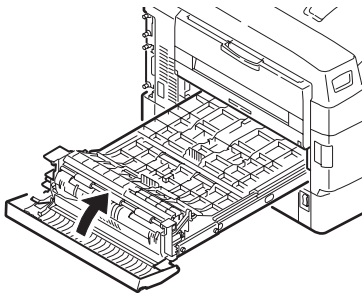

10.

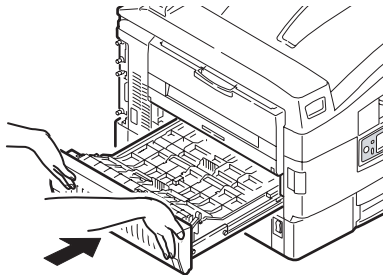

11.

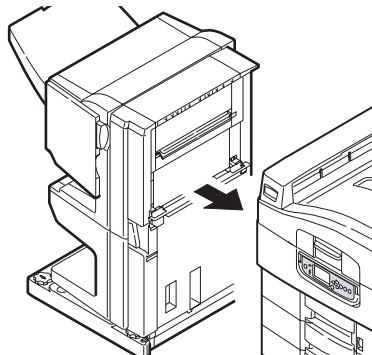

Maintenance

Cleaning the LED Heads

Cleaning the LED Heads

Clean the LED heads:

- any time you replace a toner cartridge (a LED lens cleaner is included with each replacement toner cartridge)
- if printing is showing signs of faded images, white stripes or blurred letters

1. Open the top cover.

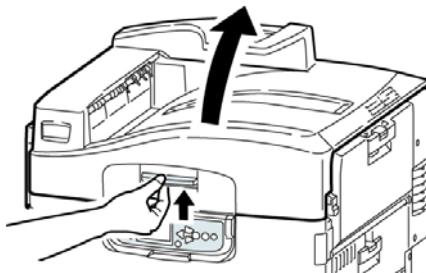

Maintenance

Cleaning the LED Heads (cont.)

2. Use the LED cleaner provided with the toner cartridges or a soft, lint-free cloth to gently wipe each of the four heads (1). Move the cleaner as shown, using a fresh section for each pass. Be careful not to damage the guards (2).

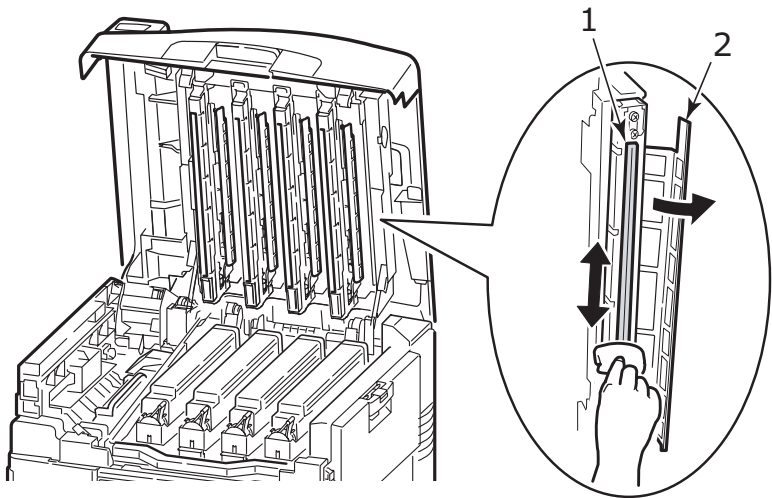

3. Close the top cover.

Maintenance

Cleaning the Paper Tray Feed Rollers

Cleaning the Paper Tray Feed Rollers

1. Remove items such as wrist watches or bracelets so they do not catch in the mechanism.



2. *If a hard disk drive is installed in the printer, press and hold the Shutdown/Reset button on the control panel for 3 seconds and wait for the display to tell you it is*

okay to turn off the printer. Otherwise go to the next step.



3. Turn the printer off.

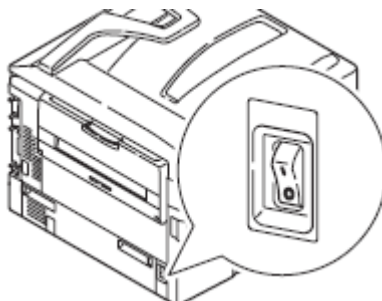

Maintenance

Cleaning the Paper Tray Feed Rollers (cont.)

4. Open Tray 1 side cover and pull out the paper guide plate (1).

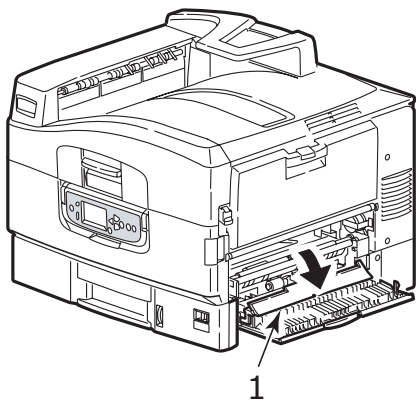

5. Remove Tray 1 from the printer.

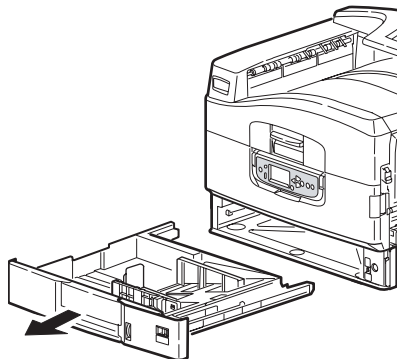

Maintenance

Cleaning the Paper Tray Feed Rollers (cont.)

6. Gaining access through the gap left by Tray 1, wipe the 3 paper feed rollers (2) with a soft cloth lightly moistened with water.

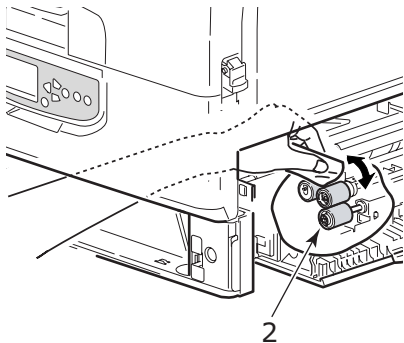

7. Replace Tray 1.

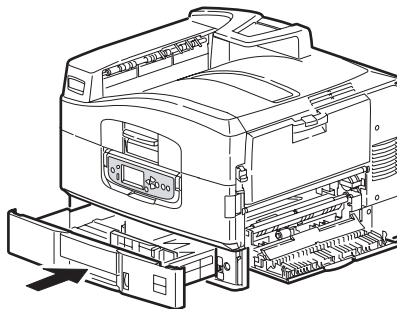

Maintenance

Cleaning the Paper Tray Feed Rollers (cont.)

8. Return the paper guide plate to its original position and close Tray 1 side cover.

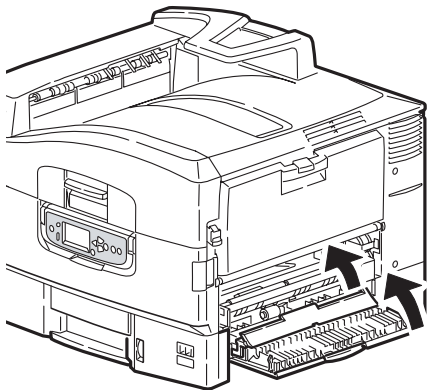

9. Turn on the printer.

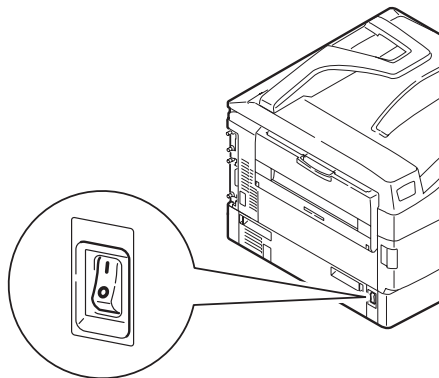

Reports

Printing Reports

Printing Reports

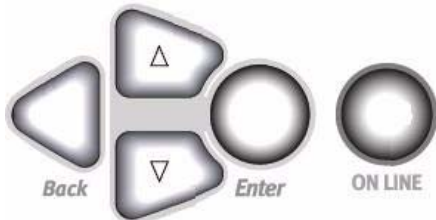

1. Press **Enter**.
2. ▽ key → Print Information. Press **Enter**.
3. ▽ key → report you wish to print:
 - **Configuration**: general information on your printer's configuration, plus a listing of the current menu settings.
 - **Network**: choose either a single-page summary printout, or a multi-page detailed list of network information.

- **Demo Page**: prints the Demo page.
 - **File List**: files stored on the printer's hard drive.
 - **PS Font List**: PostScript fonts in the printer.
 - **PCL Font List**: PCL fonts in the printer.
 - **IBM PPR Font List**: IBM ProPrinter emulation fonts in the printer.
 - **Epson FX Font List**: Epson FX emulation fonts in the printer.
 - etc. (for more information, see the on-line User's Guide on the Documentation CD provided with your printer or at <http://my.okidata.com>).
4. Press **Enter**.
The report prints and the printer goes back on line.

Error Messages

Help Button

Your printer has a built-in help system.

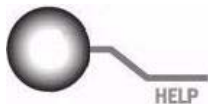

When an error message appears on the display, press HELP. The display shows information that will help you correct the error.

Use the ▾ key to move down through the Help information.

For more information, see the on-line User's Guide on the Documentation CD provided with your printer or at <http://my.okidata.com>.

Service Information

Available 24 Hours a Day, 7 Days a Week

- Visit our multilingual web site www.OkiPrintingSolutions.com
- Visit <http://my.okidata.com>
 - drivers and utilities
 - troubleshooting
 - Product news
 - and much more!
- Call 1-800-654-3282.

OKI is a registered trademark of Oki Electric Industry Company, Ltd.

3M is a trademark or registered trademark of 3M.

Adobe, and PostScript are trademarks of Adobe Systems, Inc. which may be registered in certain jurisdictions.

AMEX is a registered trademark of American Express Co.

HammerMill is a registered trademark of HammerMill.

MasterCard is a registered trademark of MasterCard International, Inc.

Xerox is a trademark of Xerox Corporation.

VISA is a registered trademark of Visa.

Wausau Exact is a registered trademark of Wausau-Mosinee Paper Corp.

Fournitures de remplacement

Renseignements concernant les achats

Endroits où se procurer les consommables

- Consultez le revendeur qui vous a vendu votre imprimante
- Consultez un revendeur ou un service après-vente Oki Data agréé. Pour connaître le revendeur le plus proche, composez le 1 800 654 3282.
- É.-U., Porto Rico, Guam, Îles Vierges des É.-U. seulement: commandez sur Internet à l'adresse <http://www.okiprintingsolutions.com>
- É.-U. seulement : commande sans frais par téléphone en composant le 1 800 654 3282, avec VISA®, MasterCard® ou AMEX®.
- Voyez les catalogues de fournitures de bureau.

Profitez des avantages de Supply Manager d'Oki!

- Calcule votre taux d'utilisation en fonction des informations que vous avez fournies.
- Vous envoie un courriel de rappel lorsque le moment est venu de commander de nouveau des fourniture.

Pour vous enregistrer, accédez à <http://www.okiprintingsolutions.com>

Numéros de pièce

Important!

Les produits consommables pour la série C9000 ne sont pas utilisables avec ces modèles. Utilisez uniquement du toner et des tambours d'image de type C7.

Fournitures de remplacement

Numéros de pièce

Cartouches de toner, type C7



Couleur	OKI N° de réf
Noir.....	42918984
Cyan	42918983
Magenta	42918982
Jaune	42918981

Tambours d'impression, type C7

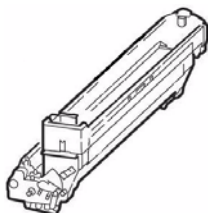

Couleur	OKI N° de réf
Noir.....	42918168
Cyan	42918167
Magenta	42918166
Jaune	42918165

Autres consommables

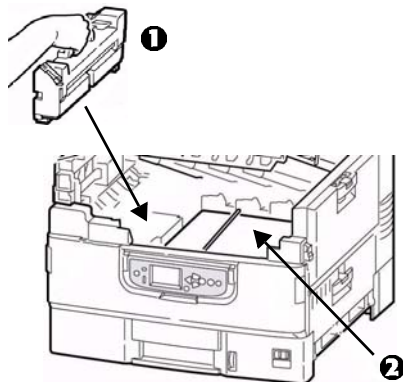

Consommable	OKI N° de réf
Unité de fusion (1)	42931701, 120V
.....	42931702, 230V
Courroie de transfert (2)	42931601
Flacon de récupération du toner	42869401

Utilisation du menu d'impression

Modifier le paramètres

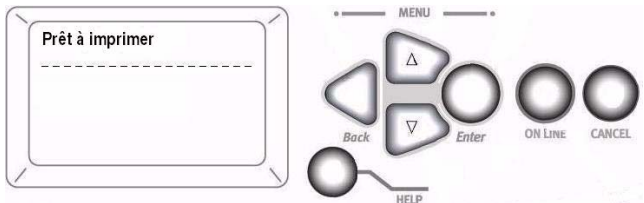

1. Appuyez sur **Enter**.

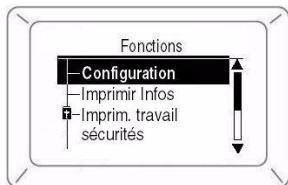

2. Utilisez la touche ∇ pour accéder à la fonction à modifier.
3. Appuyez sur **Enter**.
4. Continuez d'appuyer sur les touches ∇ et **Enter** pour accéder à

l'élément que vous désirez modifier.

5. Utilisez la touche ∇ pour accéder au réglage à sélectionner.
6. Appuyez sur **Enter**.
Un astérisque s'affiche à côté du nouveau paramètre.
7. Appuyez sur **ON LINE** pour quitter le menu.

Pour plus d'informations, affichage du Guide de l'utilisateur en ligne sur le CD de documentation fourni avec l'imprimante ou sur le <http://www.okiprintingsolutions.com>

Utilisation du menu d'impression

Sommaire du menu

– Configuration

- Compte des pages, durée utile des fournitures
- Paramètres réseau et système

– Imprimer Infos

- Configurations de l'imprimante et réseau
- Imprimer une page de démonstration
- Listes, etc.

– Imprim. travail sécurisé (Protégé par mot de passe)

Apparaît seulement si le disque dur (DD) (optionnel sur les modèles C9650n et C9650dn) est installé.

- Permet d'imprimer des documents con-fidentiels téléchargés sur le disque dur

– Menus

- Permet de définir le format, le grammage et le type des

supports pour tous les bacs papier

– Configuration admin. (Protégé par mot de passe)

- Configurations réseau diverses
- Configuration de l'impression
- Configurations PS, PCL, IBM et Epson
- Réglage des couleurs
- Configurations mémoire et mém. flash
- Configurations du disque dur et du système
- Paramètres de réinitialisation / sauvegarde / restauration

– Calibration

- Ajustements de la densité
- Registration
- Ajustement couleurs

– Statistiques d'impression (Protégé par mot de passe)

Utilisation du menu d'impression

Modification des paramètres papier

Pourquoi modifier?

Des paramètres de support erronés peuvent entraîner :

- qualité d'impression médiocre
- flaking
- *d'endommager l'imprimante*

Grammage

Le paramètre par défaut de grammage du support pour tous les bacs est AUTO.

Travaux d'impression individuels

Si vous utilisez un support spécial uniquement pour un travail d'impression, vous pouvez régler les paramètres de support *dans le pilote*. Chargez le support dans le bac approprié (normalement le bac MF). Dans l'application, cliquez sur **Fichier** → **Imprimer**. Réglez les paramètres de support tel que requis.

Pour tous les travaux (défaut)

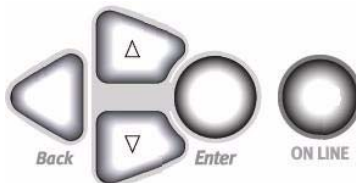

1. Appuyez sur **Enter**.
2. Touche ∇ → **Menus**. Appuyez sur **Enter**.
3. Avec **Configuration** bac mis en surbrillance, appuyer sur **Enter**.
4. Touche ∇ → bac à configurer. Appuyez sur **Enter**.
5. Utilisez les touches ∇ → et **Enter** pour parcourir les sous-menus et modifier des paramètres.
6. Appuyez sur **ON LINE** pour sortir du menu.

Utilisation du menu d'impression

Modification des paramètres par défaut

Rétablir les paramètres d'origine réglés à l'usine

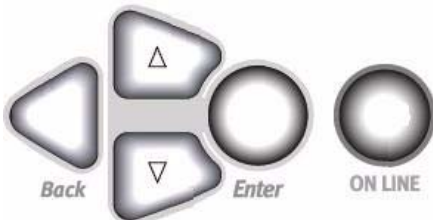

1. Appuyez sur **Enter**.
2. Utilisez la touche ∇ pour accéder à Configuration admin. Appuyez sur **Enter**.
Saisie mot de passe s'affiche.
3. Utilisez les touches Δ et ∇ pour définir le premier numéro du mot de passe. Appuyez sur **Enter**.

Remarque : Le mot de passe par défaut est aaaaaa.

4. Répétez l'étape précédente jusqu'à ce que tous les chiffres du mot de passe soient entrés.
5. Appuyez sur **Enter**.
6. Touche ∇ → **Paramètres**. Appuyez sur **Enter**.
7. Mettez en surbrillance **Réinitialiser Paramètres**. Appuyez sur **Enter**.
8. Appuyez sur **Enter**.
L'imprimante est réinitialisée.

Support d'impression

Grammage des supports

Remarque : Pour des informations sur les paramètres papier et leur rapport avec les plateaux d'alimentation et zones de sortie, consultez le guide de l'utilisateur sur le CD de documentation fourni avec votre imprimante ou <http://www.okiprintingsolutions.com>

Remarque : Sélectionnez les paramètres appropriés depuis le menu de l'imprimante ou le pilote d'imprimante.

Remarque : Les paramètres du pilote d'imprimante ont préséance sur les paramètres du menu de l'imprimante.

Bond US

Paramètre	Bond US (metric)
Auto (<i>défaut</i>)	17 à 57-lb. (64 à 216 g/m)
Léger	17-lb. (64 g/m)
Moyen léger	18 à 19-lb. (68 à 71 g/m)
Moyen	20 à 24-lb. (75 à 90 g/m)
Moyen épais	25 à 28-lb. (94 à 105 g/m)
Épais	29 à 34-lb. (109 à 128 g/m)
Très épais 1	35 à 50-lb. (132 à 188 g/m)
Très épais 2	51 à 58-lb. (192 à 218 g/m)
Très épais 3 [<i>bac MF uniquement</i>]	59 à 80-lb. (222 à 301 g/m)

Support d'impression

Grammage des supports (suite)

Index

Paramètre	Index (metric)
Auto (<i>défaut</i>)	35 à 118.6-lb. (64 à 216 g/m)
Léger	35-lb. (64 g/m)
Moyen léger	37 à 40-lb. (68 à 71 g/m)
Moyen	42 à 50-lb. (75 à 90 g/m)
Moyen épais	52 à 56-lb. (94 à 105 g/m)
Épais	60 à 71-lb. (109 à 128 g/m)
Très épais 1	73 à 104-lb. (132 à 188 g/m)
Très épais 2	106 à 141-lb. (192 à 218 g/m)
Très épais 3 [<i>bac MF uniquement</i>]	123 à 166-lb. (222 à 301 g/m)

Remarque : Pour déterminer si un grammage de papier est bond US ou Index, vérifiez l'équivalent métrique.

Exemple : 35 lb. Bond US = 132 g/m , 35 lb. Index = 64 g/m .

Pour plus d'information, visitez www.paper-paper.com/weight.html (*en anglais uniquement*).

Support d'impression

Chargement des plateaux 1-5

Chargement des supports dans les plateaux 1-5

Pour plus d'information, affichage du Guide de l'utilisateur en ligne sur le CD de documentation fourni avec l'imprimante ou sur le <http://www.okiprintingsolutions.com>

1.

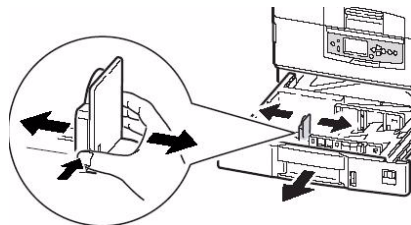

2.

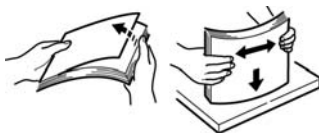

3. Côté d'impression vers le bas :

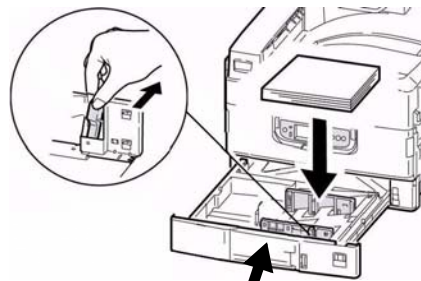

Remarque : Pour papier à en-tête :

Alimentation côté long—face vers le bas, haut de page vers l'arrière de l'imprimante :

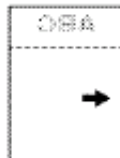

Alimentation côté court—face vers le bas, haut de page vers la droite :

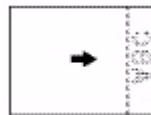

Support d'impression

Chargement du bac multifonction

Chargement des supports, bac multifonction

Pour plus d'information, affichage du Guide de l'utilisateur en ligne sur le CD de documentation fourni avec l'imprimante ou sur le <http://www.okiprintingsolutions.com>

1.

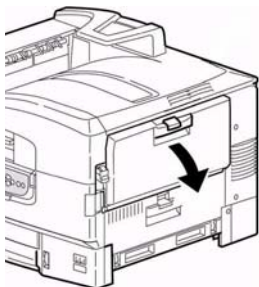

2.

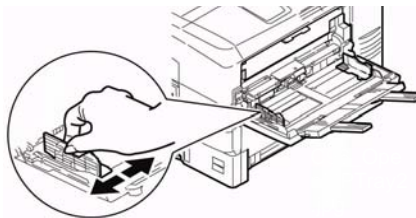

3.

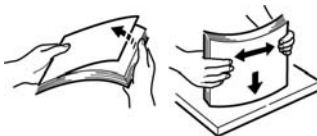

4. Côté d'impression vers le haut.

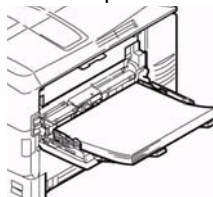

Support d'impression

Chargement du bac multifonction (suite)

Remarque : Pour papier à en-tête
(Lettre, A4 ou B5) :

Alimentation côté long—haut de page vers l'arrière de l'imprimante :

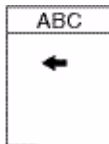

Alimentation côté court—haut de page vers l'intérieur de l'imprimante :

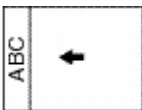

Remarque : Transparents et & étiquettes :

- le côté d'impression *vers le haut*.
- Défaut = alimentation côté long.

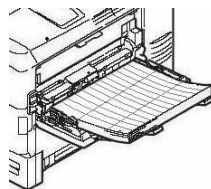

Enveloppes :

- Rabat *vers le bas*, orientée vers l'intérieur de l'imprimante :

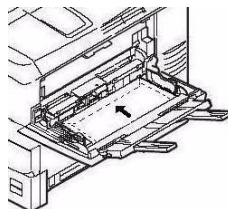

Sorties

Face vers le bas (sortie du dessus)

Ce bac est celui normalement utilisé.

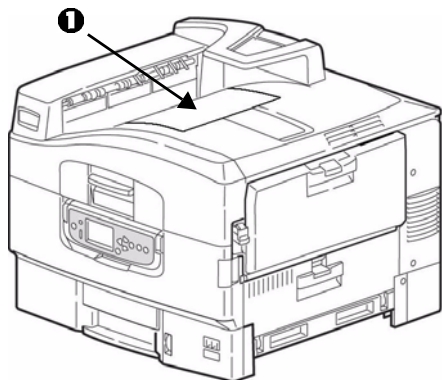

Peut contenir jusqu'à 500 feuilles de 20-lb (75 g/m).

Le bac de sortie face vers le haut (voyez la page suivante) doit être utilisé pour les supports spéciaux ou épais.

Sorties

Face vers le haut (sortie latérale)

Le bac de sortie latéral (face vers le haut) fournit un circuit d'impression droit. Utilisez un circuit d'impression droit lorsque vous imprimez transparents, étiquettes, cartonné épais, ou d'impression à partir du bac MF. Peut contenir jusqu'à 200 feuilles de 20-lb (75 g/m).

Ouvrez le bac de sortie face vers le haut

1.

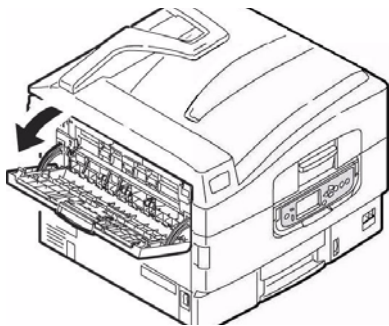

2.

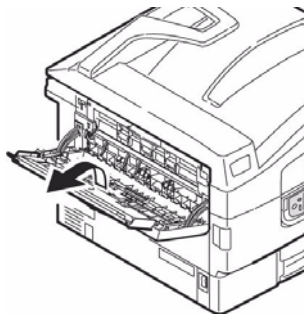

3.



Supports recommandés

Papier, Cartonné

Type de support	Recommandé
Papier	<p>Lettre :</p> <ul style="list-style-type: none">• OKI® Blanc Brillant, 32-lb. Bond US• Papier blanc radiant pour imprimante laser HammerMill®, 24-lb. Bond US• Xerox® 4024, 20-lb. Bond US <p>Tabloïde / Tabloïde Extra :</p> <ul style="list-style-type: none">• Oki Blanc Brillant, 32-lb. Bond US• Papier blanc radiant pour imprimante laser HammerMill, 24-lb. Bond US <p>Bannières :</p> <ul style="list-style-type: none">• Oki 52207901, 8.5" x 35.4", 32-lb. Bond US, 25 feuilles• Oki 52206002, 8.5" x 35.4", 32-lb. Bond US, 100 feuilles• Oki 52206001, 12.9" x 35.4", 32-lb. Bond US, 100 feuilles
Épais (cartonné)	<p>Lettre :</p> <ul style="list-style-type: none">• Oki 52205601 papier cartonné pour la série• Wausau Exact Index: 49108 (90-lb.) ou 49508 (110-lb.) <p><i>Pour éviter d'endommager l'imprimante, vérifiez les paramètres des supports de l'imprimante avant d'imprimer sur du papier épais.</i></p>

Supports recommandés

Étiquettes, Enveloppes, Transparents

Type de support	Recommandé
Étiquettes	<p>Lettre : Avery® 5161</p> <p>A4 : Avery 7162, 7664, 7666</p> <p><i>Utilisez des étiquettes pour imprimantes laser. Les étiquettes doivent recouvrir toute la feuille porteuse.</i></p>
Enveloppes	<p>COM-10 : Oki 52206301, 52206302</p> <p><i>Pour les meilleurs résultats d'impression, utilisez uniquement les enveloppes recommandées. N'utilisez jamais des enveloppes avec agrafes métalliques, fenêtres ou fermetures à rabat en V.</i></p>
Transparents	<p>Lettre :</p> <ul style="list-style-type: none">• Oki 52205701• 3M® CG3720 <p><i>Pour les meilleurs résultats d'impression, utilisez uniquement les transparents recommandés. N'utilisez jamais des transparents conçus pour être utilisés avec des marqueurs. Ceux-ci peuvent fondre et endommager l'unité de fusion de l'imprimante.</i></p>

Bourrages papier (support)

En général

Lorsque des bourrages papier se produisent souvent, vérifiez les éléments suivants.

- L'imprimante est-elle de niveau?
- Le support utilisé est-il à l'intérieur des spécifications? Des bourrages papier se produiront souvent lorsque des supports trop minces ou trop épais sont utilisés.
- Les paramètres (imprimante et pilote) sont-ils appropriés au type de support utilisé?
- N'utilisez pas des supports gondolés ou recourbés.
- Retirez le support du bac. Aérez et aligner la pile. Remettez en place la pile de support.

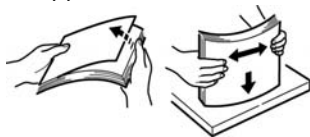

- Les enveloppes se bloquent dans l'appareil. Assurez-vous que la pile est bien alignée. Les enveloppes doivent être chargées avec le rabat vers le bas, partie supérieure vers l'imprimante.

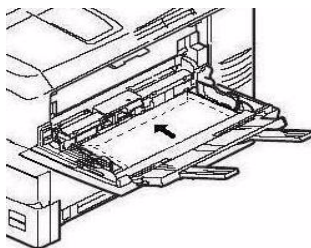

- Nettoyez le cylindre d'alimentation (voyez la page 66).

Remarque :

pour plus d'informations, affichage du Guide de l'utilisateur en ligne sur le CD de documentation fourni avec l'imprimante ou sur le <http://www.okiprintingsolutions.com>

Bourrages papier (support)

Couvercle latéral de bac

Couvercle latéral de bac

1.

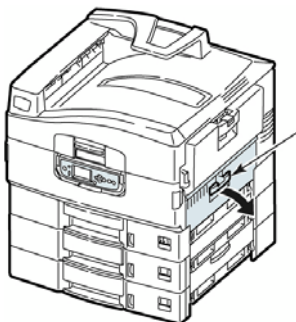

Serrez le loquet et ouvrez le couvercle

2. Tenez la languette et tournez le guide-papier vers l'extérieur

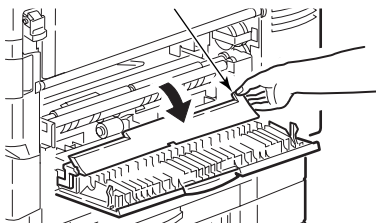

3.

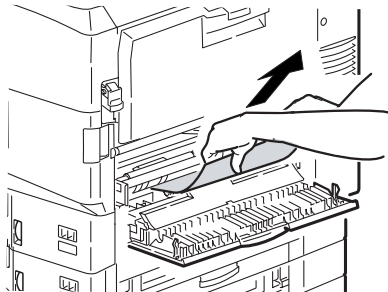

4.

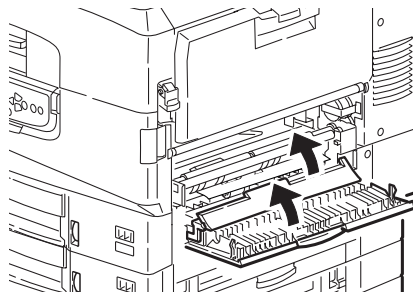

Bouffrages papier (support)

Couvercle latéral de l'imprimante

Couvercle latéral de l'imprimante

1.

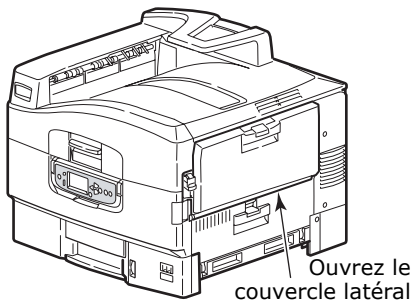

2.

Tirez le levier de déverrouillage et ouvrez le couvercle latéral

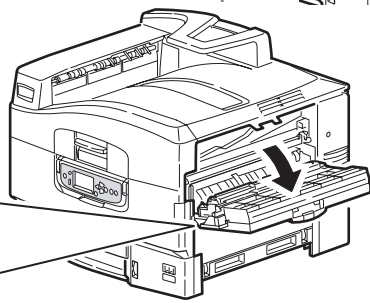
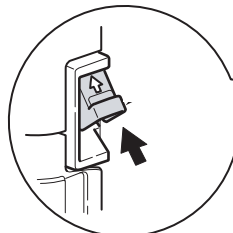

3.

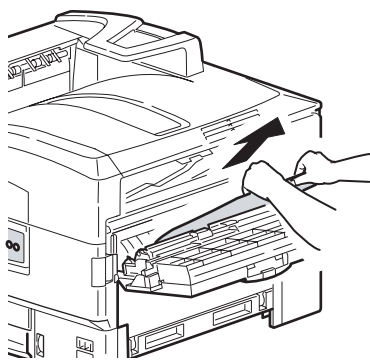

4.

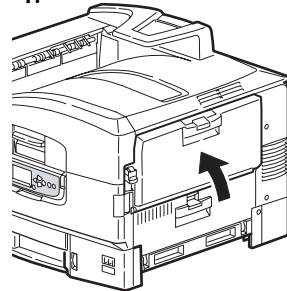

Bourrages papier (support)

Capot supérieur de l'imprimante

Capot supérieur de l'imprimante

1. Serrez le levier du couvercle supérieur

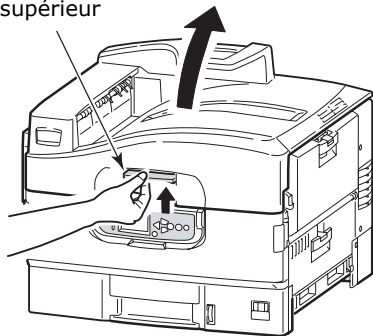

AVERTISSEMENT!

Faites attention de ne pas toucher l'unité de fusion qui est chaude après l'impression.

- 2.

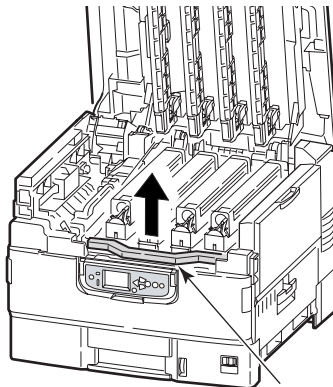

Serrez le levier du panier et soulevez le panier du tambour

- 3.

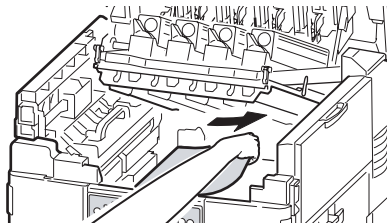

Bourrages papier (support)

Capot supérieur de l'imprimante (suite)

AVERTISSEMENT!

Faites attention de ne pas toucher l'unité de fusion qui peut être chaude après l'impression. Si l'unité de fusion est chaude, attendez qu'elle se soit refroidie avant de tenter de retirer le papier bloqué.

4. Unité de fusion

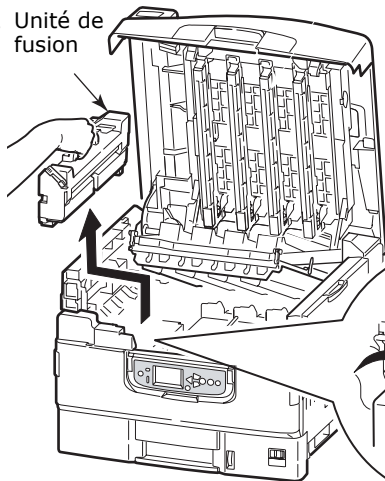

5. Tirez vers le haut les leviers de déverrouillage pour dégager le papier coincé

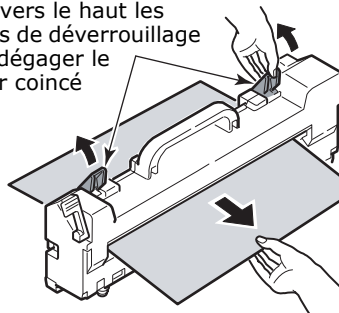

Poussez le levier de verrouillage



Bourrages papier (support)

Capot supérieur de l'imprimante (suite)

6.

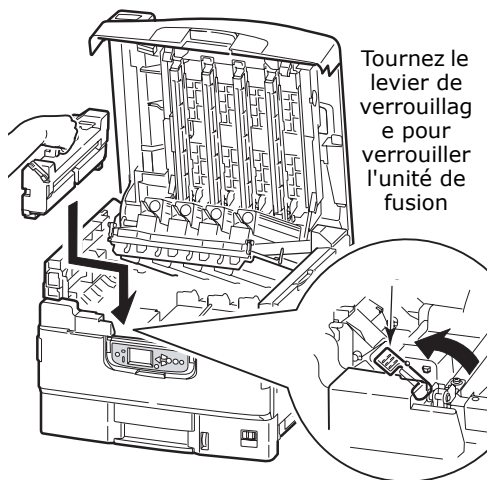

7.

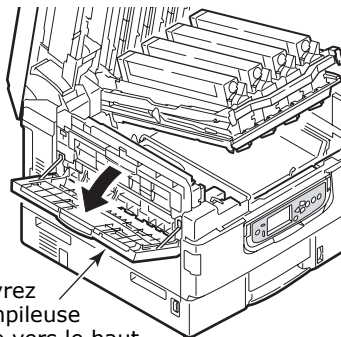

8.

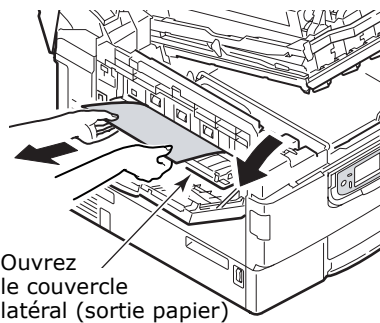

Bourrages papier (support)

Capot supérieur de l'imprimante (suite)

9.

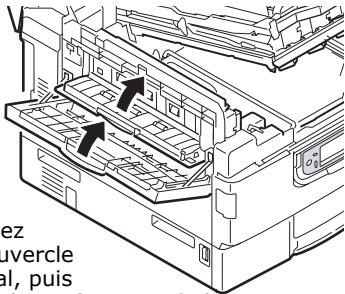

Fermez le couvercle latéral, puis l'empileuse face vers le haut

10.

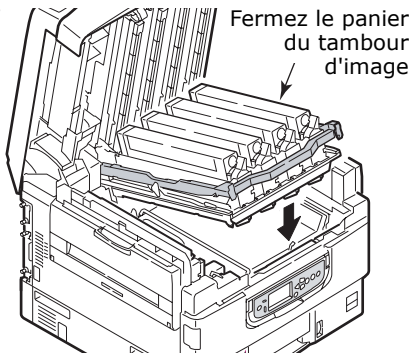

Fermez le panier du tambour d'image

11.

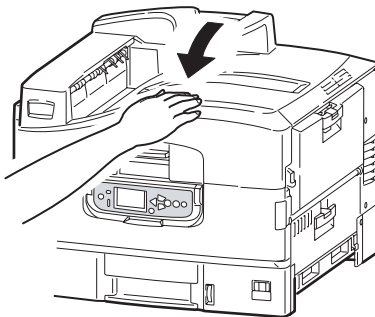

Bourrages papier (support)

Unité recto verso

Unité recto verso

1.

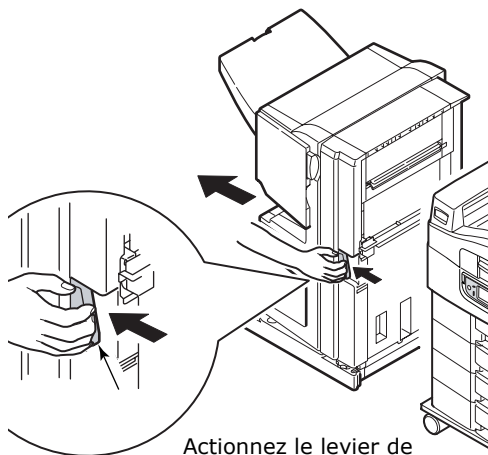

Actionnez le levier de l'inverseur et séparez de l'imprimante

2.

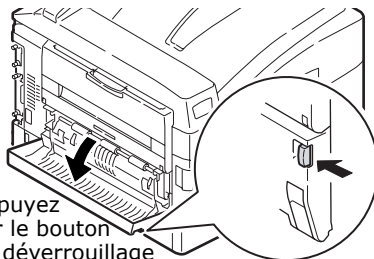

Appuyez sur le bouton de déverrouillage du couvercle de l'unité recto verso et ouvrez le couvercle

3.

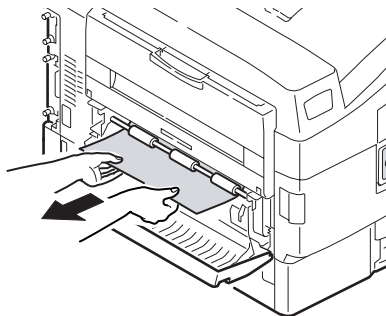

Bourrages papier (support)

Unité recto verso (suite)

4.

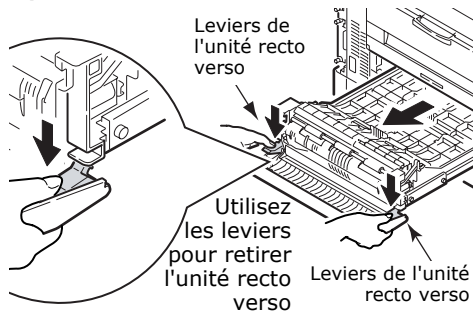

5.

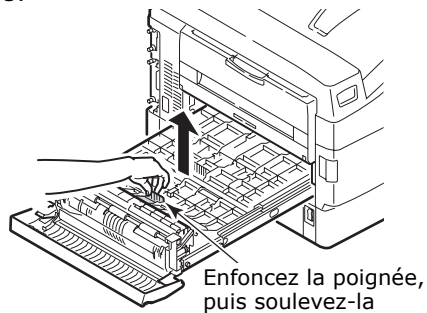

6.

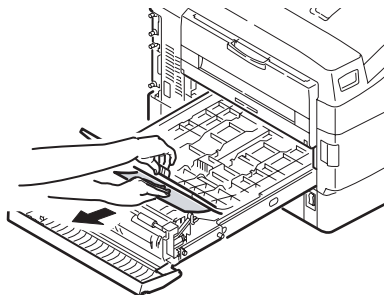

7.

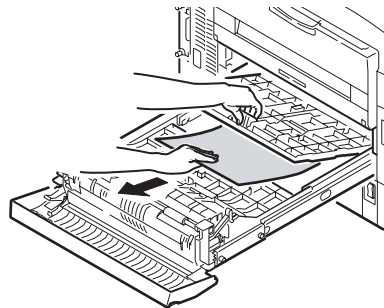

Bourrages papier (support)

Unité recto verso (suite)

8.

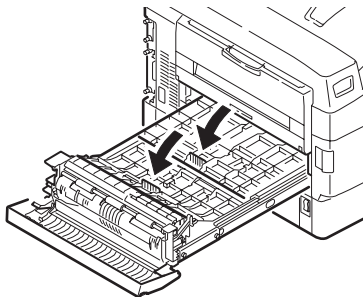

9.

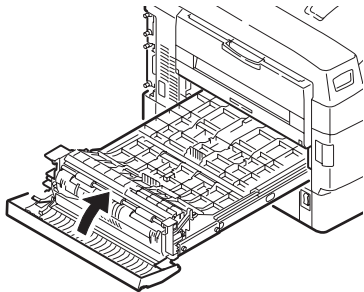

10.

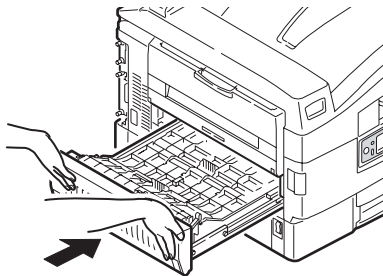

11.

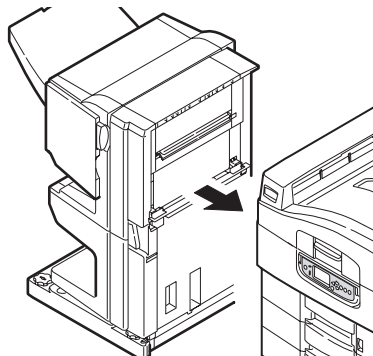

Entretien

Nettoyage de la matrice à DEL

Nettoyage de la matrice à DEL

Nettoyez les têtes à DEL :

- chaque fois que vous remplacez une cartouche de toner (un nettoyant de lentille à DEL est inclus avec chaque cartouche de toner de remplacement)
- si l'impression présente des signes d'images estompées, de bandes blanches ou de lettres flous

1. Ouvrez le couvercle supérieur.

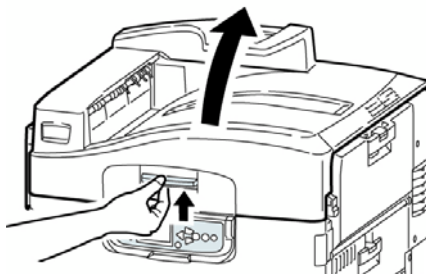

Entretien

Nettoyage de la matrice à DEL (suite)

2. Utilisez le nettoyant pour lentille à DEL fourni avec les cartouches de toner ou un chiffon doux non pelucheux pour essuyer délicatement chacune des quatre têtes (1). Déplacez le nettoyant tel que montré, en utilisant une section fraîche à chaque passage. Faites attention de ne pas endommager les protecteurs (2).

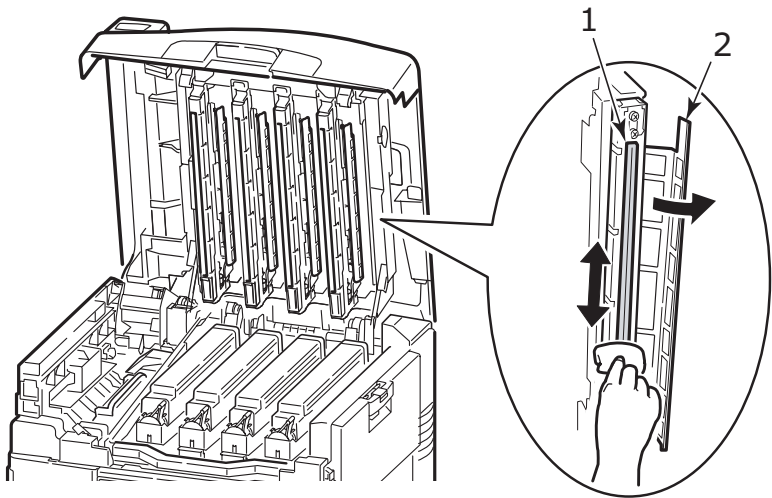

3. Fermez le capot supérieur.

Entretien

Nettoyage des rouleaux d'alimentation du plateau de papier

Nettoyage des rouleaux d'alimentation du plateau de papier

1. Retirez les montres, bracelets et autres éléments similaires qui pourraient se prendre dans le mécanisme.



2. *Si un disque dur est installé dans l'imprimante*, appuyez et maintenez enfoncé le bouton d'arrêt/de réinitialisation sur le panneau de commande pendant 3 secondes et attendez que l'affichage confirme qu'il est permis d'éteindre l'imprimante en toute

sécurité. Sinon, allez à la prochaine étape.



3. Éteignez l'imprimante.

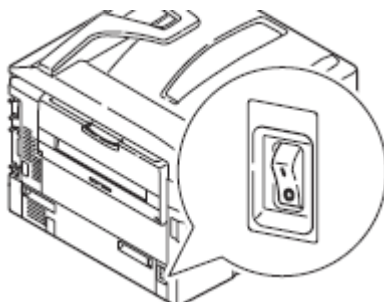

Entretien

Nettoyage des rouleaux d'alimentation du plateau de papier (suite)

4. Ouvrez le couvercle latéral du bac 1 et sortez la plaque du guide-papier (1).

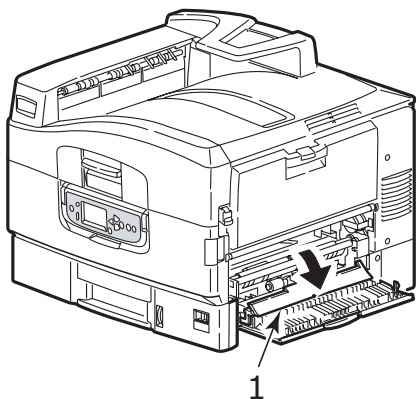

5. Retirez le plateau 1 de l'imprimante.

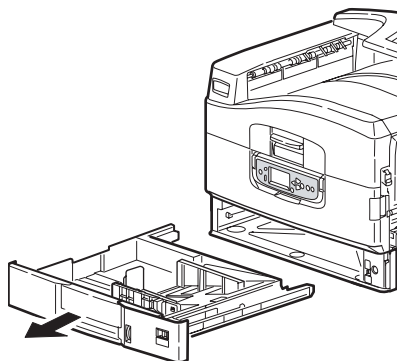

Entretien

Nettoyage des rouleaux d'alimentation du plateau de papier (suite)

6. En accédant à travers l'écart laissé par le bac 1, essayez les 3 rouleaux d'alimentation papier (2) avec un tissu doux légèrement humecté d'eau.

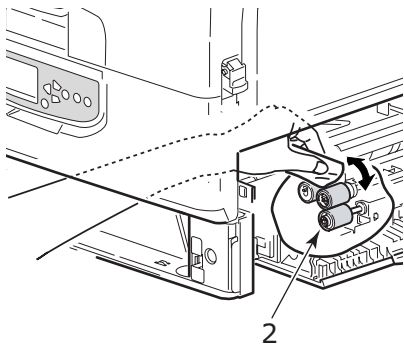

7. Remplacez le bac 1.

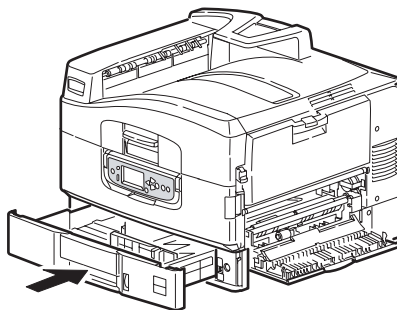

Entretien

Nettoyage des rouleaux d'alimentation du plateau de papier (suite)

8. Ramenez la plaque du guide-papier à sa position originale et fermez le couvercle latéral du bac 1.

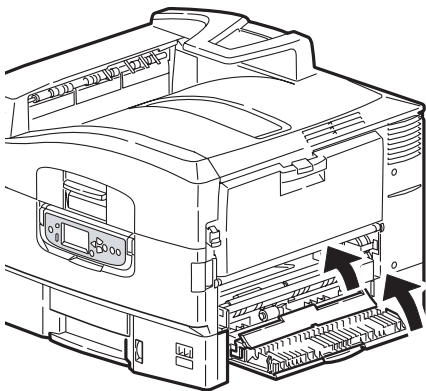

9. Mettez sous tension l'imprimante.

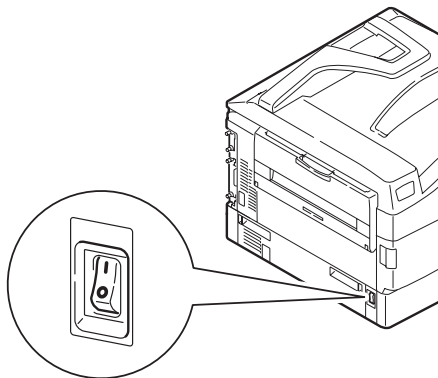

Rapports

Impression de Rapports

Impression de Rapports

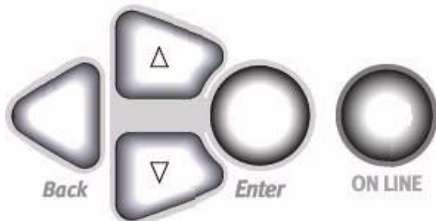

1. Appuyez sur **Enter**.
2. Touche ∇ → **Imprimer Infos**.
Appuyez sur **Enter**.
3. Touche ∇ → le rapport à imprimer :
 - Configuration : renseignements généraux sur la configuration de l'imprimante, en plus d'une liste des paramètres de menu courants.
 - Network [Réseau] : choisissez un imprimé sommaire d'une page ou une liste détaillée de plusieurs pages de renseignements sur le réseau.

- Demo Page [Page de démonstration] : pour imprimer la page de démonstration.
 - File List [Liste des fichiers] : les fichiers stockés sur le disque dur interne de l'imprimante.
 - PS Font List [Liste des polices PS] : polices PostScript de l'imprimante.
 - PCL Font List [Liste des polices PCL] : polices PCL de l'imprimante.
 - IBM PPR Font List [Liste des polices IBM PPR] : IBM ProPrinter emulation fonts in the printer.
 - Epson FX Font List [Liste des polices Epson FX] : polices d'émulation Epson FX de l'imprimante.
 - etc. (pour plus d'information, affichage du Guide de l'utilisateur en ligne en ligne sur le CD de documentation fourni avec l'imprimante ou sur le <http://www.okiprintingsolutions.com>)
4. Appuyez sur **Enter**.
Le rapport est imprimé et l'imprimante se remet en ligne.

Messages d'erreur

le bouton Help

L'imprimante possède un système d'aide intégrée.

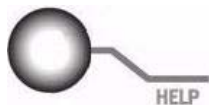

Lorsqu'un message d'erreur s'affiche, appuyez sur HELP [AIDE]. L'affichage indique des renseignements qui vous aideront à supprimer l'erreur.

Utilisez la touche ▾ pour parcourir les renseignements d'aide.

Pour plus d'information, affichage du Guide de l'utilisateur en ligne en ligne sur le CD de documentation fourni avec l'imprimante ou sur le <http://www.okiprintingsolutions.com>

Information de service

Disponible 24 heures par jour, 7 jours sur 7

- Visitez notre site Web multilingue <http://www.okiprintingsolutions.com>
- Visitez <http://my.okidata.com> (*en anglais uniquement*)
 - pilotes et utilitaires
 - dépannage
 - Nouvelles sur les produits
 - et plus encore!
- Composez le 1-800-654-3282.

OKI est une marque déposée de Oki Electric Industry Company, Ltd.

3M est une marque déposée ou une marque de commerce de la Compagnie 3M

Adobe et PostScript sont des marques de commerce de Adobe Systems, Inc. lesquelles peuvent être déposées dans certains territoires.

AMEX est une marque déposée de American Express Co.

HammerMill est une marque déposée de HammerMill.

MasterCard est une marque déposée de MasterCard International, Inc.

Xerox est une marque déposée de Xerox Corporation.

VISA est une marque déposée de Visa.

Wausau Exact est une marque déposée de Wausau-Mosinee Paper Corp.

Suministros de repuesto

Información de compras, Número de partes

Dónde comprar

- Consulte el distribuidor donde compró su impresora
- Consulte un Distribuidor autorizado o un Proveedor de Servicios de Oki Data. Para averiguar cual es el distribuidor más cercano, llame al 1-800-654-3282 [solamente EE.UU. & Canadá, Inglés únicamente] o llamando al 1-856-222-7496 (Español únicamente).
- *Solo en EE.UU., Puerto Rico, Guam, Islas Virgenes (EE.UU.):* Haga sus pedidos en la Internet **<http://www.okiprintingsolutions.com>**
- *Solo EE.UU.:* Llamada sin cargo al 1-800-654-3282 (Inglés únicamente), y utilice su tarjeta VISA[®], MasterCard[®] o AMEX[®].
- Refiérase a los catálogos de suministros de oficina.

Oki's Supply Manager

- Calcula su consumo de acuerdo a la información que usted suministra.
- Le envía por correo electrónico un recordatorio de que debe colocar su pedido.

Para registrar, vaya a

<http://www.okiprintingsolutions.com>

Número de partes

¡Importante!

Los consumibles para "C9000 Series" no funcionan con estos modelos. Solo utilice Tóner Tipo C7 cartuchos de tóner y cilindro de imagen.

Suministros de repuesto

Número de partes (cont.)

Cartuchos de tóner, Tipo C7



Color	OKI No. de Pieza
Negro	42918984
Cian	42918983
Magenta	42918982
Amarillo	42918981

Cilindro de imagen, Tipo C7

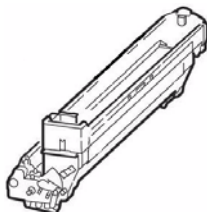

Color	OKI No. de Pieza
Negro	42918168
Cian	42918167
Magenta	42918166
Amarillo	42918165

Otros consumibles

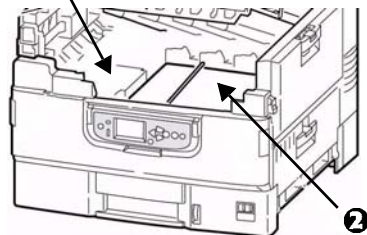
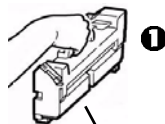

Consumible	OKI No. de Pieza
Fusor (1)	42931701, 120V
.....	42931702, 230V
Cinta de transporte (2)	42931601
Botella de desechos de tóner	42869401

Cómo utilizar el menú de la impresora

Cambiar configuración

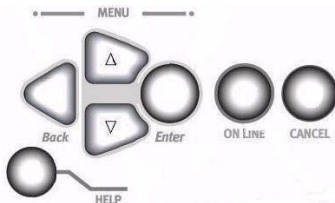
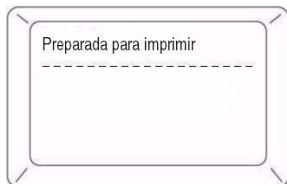

1. Presione **Enter**.

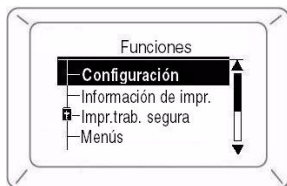

2. Utilice el tecla ∇ para deslizarse hacia abajo y encontrar la función que desea cambiar.
3. Presione **Enter**.
4. Siga utilizando el tecla ∇ y **Enter** para deslizarse hacia abajo hasta

llegar al ítem que desea utilizar.

5. Utilice el tecla ∇ para deslizarse hasta la configuración que desea seleccionar.
6. Presione **Enter**.
Aparece un asterisco al lado del Valor.
7. Presione **ON LINE** para salir del modo Menú.

Para mayor información, refiérase a la Guía del Usuario en línea en el CD con documentación que vino con su <http://www.okiprintingsolutions.com>

Cómo utilizar el menú de la impresora

Resumen del menú

– Configuración

- Conteo de páginas, vida útil de los suministros
- Configuración de la Red y el Sistema

– Información de impr.

- Configuración de la Impresora y la Red
- imprimir una página de demostración
- Listas, etc.

– Impr.trab. segura (protegido con una contraseña)

Sólo aparece si está instalada la Unidad de disco duro (HDD) (opcional en los Modelos C9650n y C9650dn).

- Imprimir documentos confidenciales que han sido transferidos al disco duro

– Menús

- Configure el tamaño, peso y tipo de medio para las diferentes

bandejas de alimentación

– Config. admin. (protegido con una contraseña)

- Varias configuraciones de red
- Configuración de impresión
- Configuración de PS y PCL
- Configuración de emulación IBM y Epson
- Configuración de la memoria normal y la memoria Flash.
- Configuración del Disco Duro y del Sistema.
- Reiniciar/Volver a los valores por defecto/Guardar la configuración.

– Calibración

- Ajustes de la densidad
- Registración
- Sintonizando Color

– Estadísticas de impr. (protegido con una contraseña)

Cómo utilizar el menú de la impresora

Cómo cambiar la configuración del papel

¿Por qué es necesario cambiar?

La configuración equivocada del tipo de medio puede ocasionar:

- calidad de impresión inferior
- escamas en los impresos
- *dañar la impresora*

Peso del medio

El valor predeterminado del peso del medio para todas las bandejas es AUTO.

Para tareas de impresión individuales

Si va a utilizar un medio especial para una sola tarea, puede ajustar la configuración del medio *en el controlador*. Coloque el medio en la bandeja apropiada (generalmente la bandeja MP). En su aplicación, haga clic en **Archivo** → **Imprimir** y configure el medio si es necesario.

Todas los trabajos de impresión (Valores predeterminados)

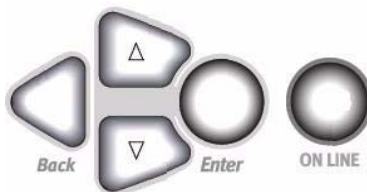

1. Presione **Enter**.
2. Tecla ∇ → Menús. Presione **Enter**.
3. Teniendo seleccionado **Config. bandejas**, presione **Enter**.
4. Tecla ∇ → bandeja a configurar. Presione **Enter**.
5. Utilice las teclas ∇ y **Enter** para deslizarse en los submenús y hacer los cambios que desea.
6. Presione **ON LINE** para salir del modo Menú.

Cómo utilizar el menú de la impresora

Cambio de los valores predeterminados

Volver a los valores por defecto de fábrica

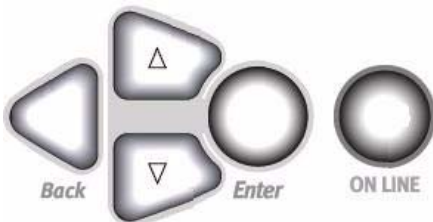

1. Presione **Enter**.
2. Utilice el botón ∇ para deslizarse hasta **Config. admin**. Presione **Enter**.
Aparece el Introd. contraseña.
3. Utilice los botones Δ y ∇ para fijar el primer dígito de su contraseña. Presione **Enter**.

Nota: La contraseña por defecto es aaaaaa.

4. Repita el paso anterior hasta entrar los cuatros dígitos de la contraseña.
5. Presione **Enter**.
6. Tecla ∇ \rightarrow **Ajustes**. Presione **Enter**.
7. Resalte **Reiniciar ajustes**. Presione **Enter**.
8. Presione **Enter**.

La impresor se reinicia y vuelve al estado Preparada para imprimir.

Medios de impresión

Gramaje del papel

Nota: Para información sobre la configuración del papel en cuanto a las bandejas de entrada y de salida, vea la Guía del Usuario en el CD con la documentación que vino con su impresora o visite <http://www.okiprintingsolutions.com>.

Nota: Seleccione la configuración apropiada en el menú o en el controlador de la impresora.

Nota: La configuración del controlador tiene precedencia sobre la configuración de los menús de la impresora.

US Bond

Ajuste	US Bond (Métrico)
Auto (<i>predeterminado</i>)	17 a 57-lb. (64 a 216 g/m)
Light [Ligero]	17-lb. (64 g/m)
Medium Light [Ligero Mediano]	18 a 19-b. (68 a 71 g/m)
Medium [Mediano]	20 a 24-lb. (75 a 90 g/m)
Medium Heavy [Pesado Mediano]	25 a 28-lb. (94 a 105 g/m)
Heavy [Pesado]	29 a 34-lb. (109 a 128 g/m)
Ultra heavy 1 [Ultra Pesado 1]	35 a 50-lb. (132 a 188 g/m)
Ultra heavy 2 [Ultra Pesado 2]	51 a 58-lb. (192 a 218 g/m)
Ultra heavy 3 [Ultra Pesado 3] (<i>solo Bandeja MU</i>)	59 a 80-lb. (222 a 301 g/m)

Medios de impresión

Gramaje del papel (cont.)

Índice

Ajuste	Índice (Métrico)
Auto (<i>predeterminado</i>)	35 a 118.6-lb. (64 a 216 g/m)
Light [Ligero]	35-lb. (64 g/m)
Medium Light [Ligero Mediano]	37 a 40-lb. (68 a 71 g/m)
Medium [Mediano]	42 a 50-lb. (75 a 90 g/m)
Medium Heavy [Pesado Mediano]	52 a 56-lb. (94 a 105 g/m)
Heavy [Pesado]	60 a 71-lb. (109 a 128 g/m)
Ultra heavy 1 [Ultra Pesado 1]	73 a 104-lb. (132 a 188 g/m)
Ultra heavy 2 [Ultra Pesado 2]	106 a 141-lb. (192 a 218 g/m)
Ultra heavy 3 [Ultra Pesado 3] (<i>solo Bandeja MU</i>)	123 a 166-lb. (222 a 301 g/m)

Nota: Para determinar si el peso del papel es US Bond o Índice, verifique el equiva-lente métrico.

Ejemplo: 35 lb. *US Bond* = 132 g/m , 35 lb. Índice = 64 g/m

Para mayor información, vaya a www.paper-paper.com/weight.html (*en inglés único*).

Cómo cargar papel

Bandejas de papel 1-5

Cómo cargar papel en las bandejas 1-5

Para mayor información, refiérase a la Guía del Usuario en línea en el CD con documentación que vino con su impresora o en

<http://>

www.okiprintingsolutions.com

1.

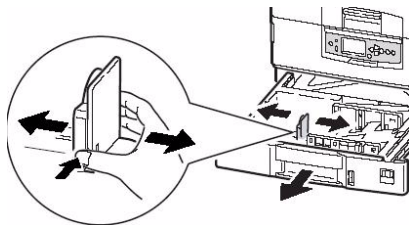

2.

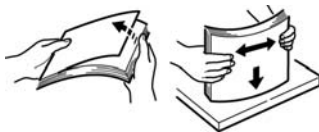

3. El lado de impresión *hacia abajo*:

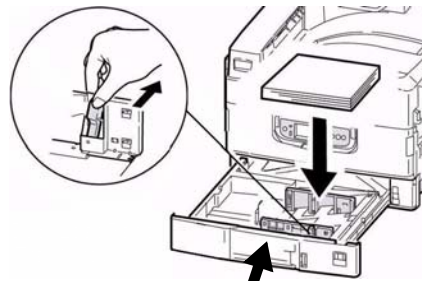

Nota: Para papel membrete:

Alimentación borde largo—Cara abajo, el borde superior en dirección a la parte posterior de la impresora.

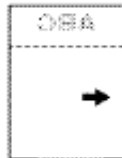

Alimentación borde corto—Cara abajo, el borde superior hacia la derecha:



Cómo cargar papel

Cómo cargar papel en la Bandeja multiuso

Cómo cargar papel, Bandeja multiuso

Para mayor información, refiérase a la Guía del Usuario en línea en el CD con documentación que vino con su impresora o en

<http://>

www.okiprintingsolutions.com

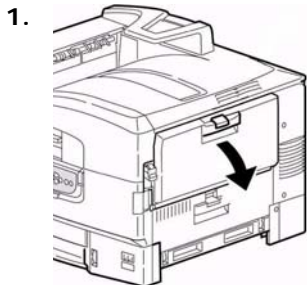

2.

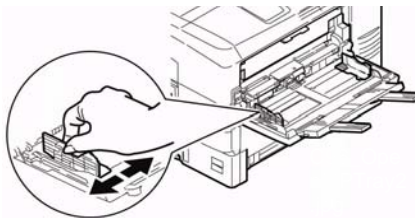

3.

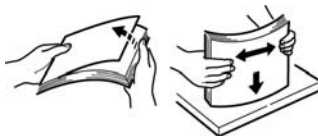

4. El lado imprimible *hacia arriba*.

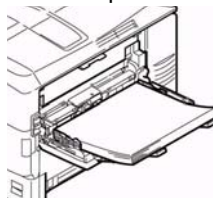

Cómo cargar papel

Cómo cargar papel en la Bandeja multiuso (cont.)

Nota: Papel membrete (Carta, A4 ó B5):

Alimentación borde largo—el borde superior hacia la parte posterior de la impresora:

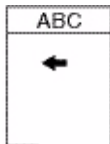

Alimentación borde corto—el borde superior en dirección de la parte delantera de la impresora:

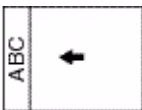

Nota: Transparencias & Etiquetas:

- El lado imprimible *hacia arriba*.
- Predeterminado = Alimentación borde largo.

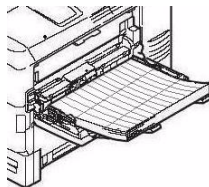

Sobres:

- Solapa *hacia abajo*, en dirección de la impresora:

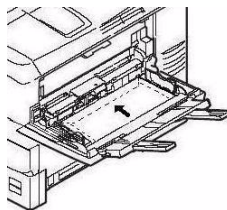

Rutas de salida

Cara Abajo (Salida superior)

Esta es la bandeja que se utiliza normalmente.

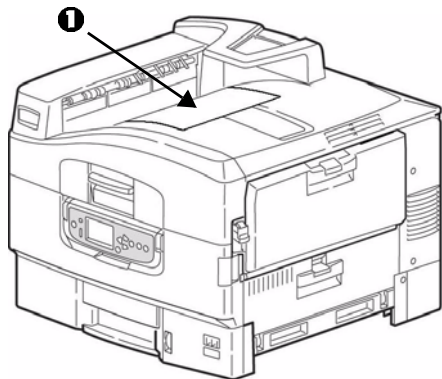

Capacidad de 500 hojas de papel de 20-lb. (75 g/m²).

La bandeja de salida cara arriba (ver la siguiente página) debe utilizarse para medios especiales y papel pesado.

Rutas de salida

Cara Arriba (Salida lateral)

La bandeja de salida (cara arriba) tiene un trayecto de impresión recto. Utilice este trayecto para imprimir transparencias, etiquetas, tarjetas,, ó para impresión por la Bandeja MU. Capacidad de 200 hojas de papel de 20-lb. (75 g/m²).

Para abrir la bandeja de salida cara arriba

1.

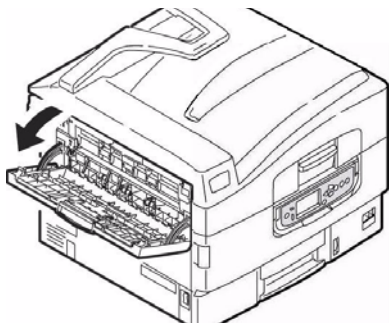

2.

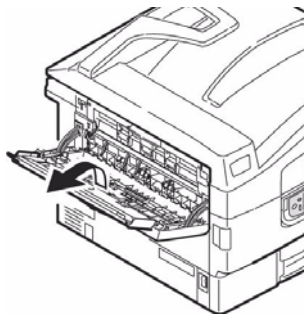

3.



Medios de impresión recomendados

Papel, Cartulina

Tipo de medio	Recomendado
Papel	<p>Carta:</p> <ul style="list-style-type: none">• OKI® 52208001 Bright White, 32-lb. US Bond• HammerMill® Laser Print Radiant, Blanca, 24-lb. US Bond• Xerox® 4024, 20-lb. US Bond <p>Tabloide/Tabloide Extra:</p> <ul style="list-style-type: none">• Oki 52206102, 52206103 Bright White, 32-lb. US Bond• HammerMill Laser Print Radiant, Blanca, 24-lb. US Bond <p>Pancartas:</p> <ul style="list-style-type: none">• Oki 52207901, 8.5" x 35.4", 32-lb. US Bond, 25 hojas• Oki 52206002, 8.5" x 35.4", 32-lb. US Bond, 100 hojas• Oki 52206001, 12.9" x 35.4", 32-lb. US Bond, 100 hojas
Grueso (Cartulina)	<p>Carta:</p> <ul style="list-style-type: none">• Oki 52205601 Cartulina• Wausau Exact Index: 49108 (90-lb.) o 49508 (110-lb.) <p><i>Para evitar daños a la impresora, es muy importante que verifique la configuración de los medios de impresión de la impresora antes de imprimir en papel grueso.</i></p>

Medios de impresión recomendados

Etiquetas, Sobres, Transparencias

Tipo de medio	Recomendado
Etiquetas	<p>Carta: Avery® 5161</p> <p>A4: Avery 7162, 7664, 7666</p> <p><i>Utilice etiquetas para impresoras láser. Las etiquetas deben cubrir completamente la hoja de soporte.</i></p>
Sobres	<p>COM-10: Oki 52206301, 52206302</p> <p><i>Para el mejor resultado, sólo utilice los sobres recomendados. No utilice sobres con ganchos metálicos, cierres, ventanas o solapas en forma de V.</i></p>
Transparencias	<p>Carta:</p> <ul style="list-style-type: none">• Oki 52205701• 3M® CG3720 <p><i>Para el mejor resultado, sólo utilice las transparencias recomendadas. Nunca utilice transparencias diseñadas para utilizarse a mano con marcadores. Las mismas se derriten en la unidad de fusor y causan daños.</i></p>

Atascos de papel (Medios) en General

Si el papel se atasca constantemente, verifique lo siguiente.

- ¿Está la impresora correctamente nivelada?
- ¿El medio que está utilizando se ajusta a las especificaciones? Los medios demasiado ligeros o pesados generalmente causan atascos.
- ¿Tiene la configuración correcta (impresora y controlador) para el tipo de medio que está utilizando?
- No utilice medios de impresión arrugados o doblados.
- Retire el medio de la bandeja. Abanique/alinee la pila. Vuelva a cargar el medio.

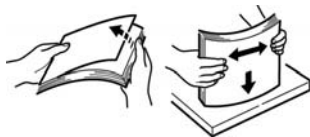

- Los sobres se están atascando. Asegúrese de que la pila esté correctamente alineada. Los sobres deben cargarse con la solapa hacia abajo y el borde superior en dirección de la impresora.

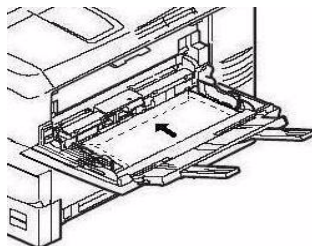

- Limpie el rodillo de alimentación (ver página 100).

Nota: Para mayor información, refiérase a la Guía del Usuario en línea en el CD con documentación que vino con su impresora o en <http://www.okiprintingsolutions.com>

Atascos de papel (Medios)

Tapa lateral de la bandeja

Tapa lateral de la bandeja

1.

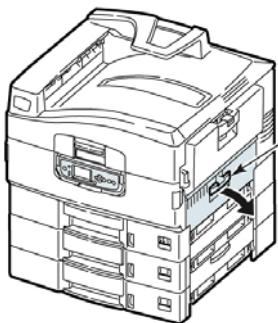

Apriete el
enganche
y abra la
tapa

2.

Sostenga la pestaña y gire
hacia afuera la guía de papel

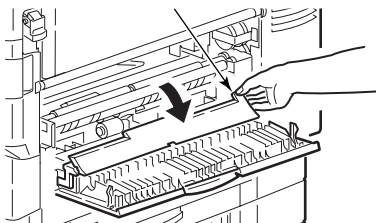

3.

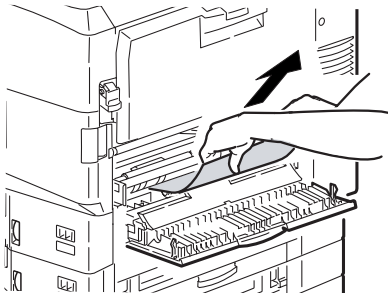

4.

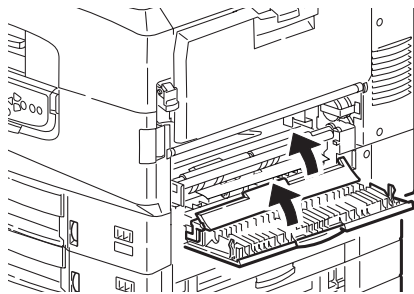

Atascos de papel (Medios)

Tapa lateral de la impresora

Tapa lateral de la impresora

1.

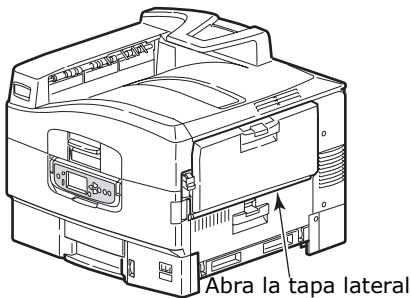

3.

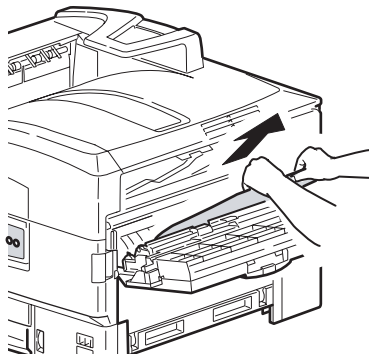

2.

Hale la palanca de liberación y abra la tapa lateral

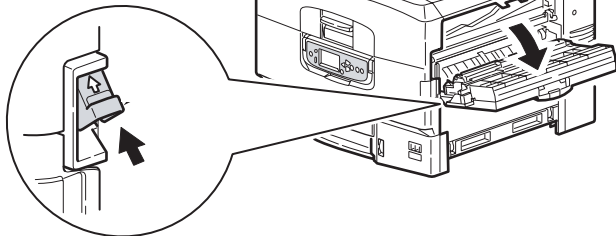

4.

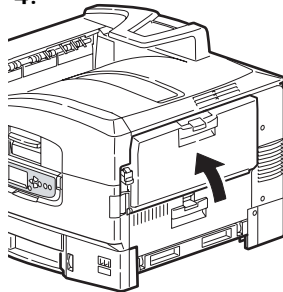

Atascos de papel (Medios)

Tapa superior de la impresora

Tapa superior de la impresora

1. Apriete la manivela de la tapa superior

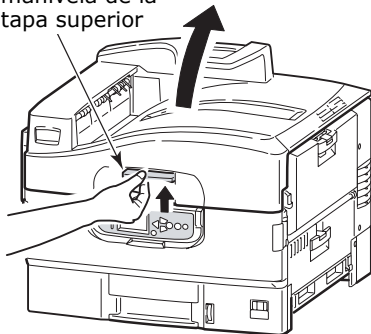

¡ADVERTENCIA!

Evite tocar la unidad de fusor que se calienta después de imprimir.

- 2.

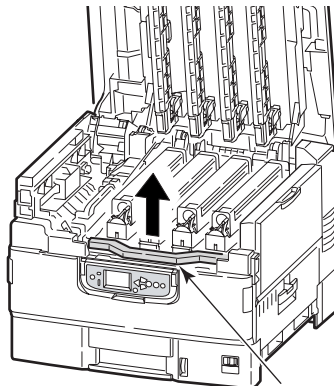

Apriete la manivela de canasta y levante la canasta de cilindros

- 3.

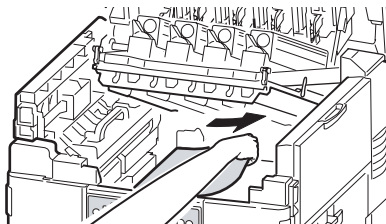

Atascos de papel (Medios)

Tapa superior de la impresora (continuación)

¡ADVERTENCIA!

Evite tocar la unidad de fusor que se calienta después de imprimir. Si la unidad de fusor está caliente, espere a que se enfríe antes de retirar el papel atascado.

4.

Unidad de fusor

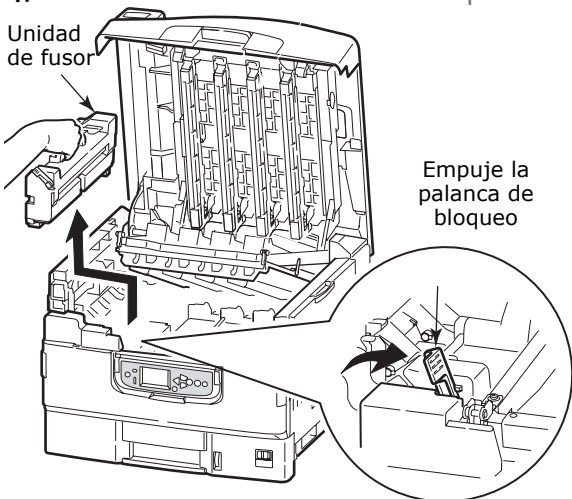

5.

Hale hacia afuera las palancas liberadoras para soltar el papel

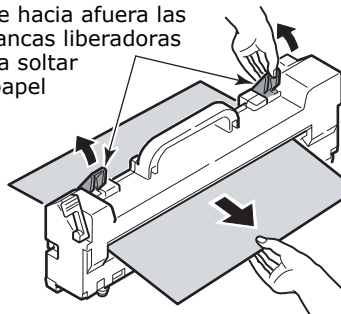

Atascos de papel (Medios)

Tapa superior de la impresora (cont.)

6.

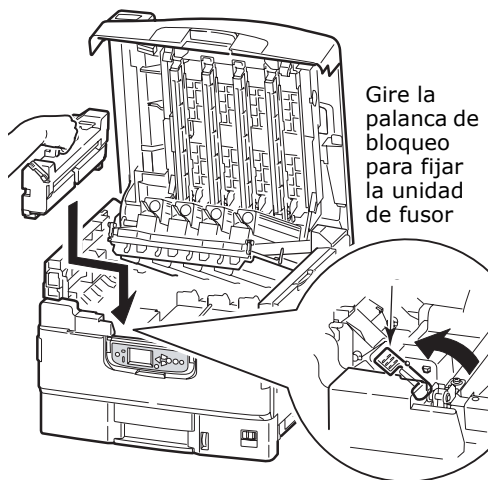

7.

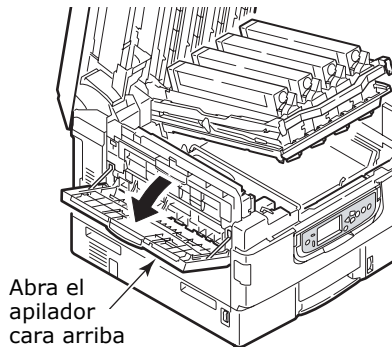

8.

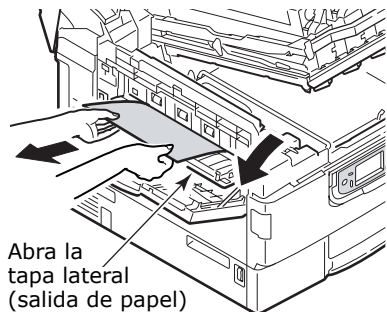

Atascos de papel (Medios)

Tapa superior de la impresora (cont.)

9.

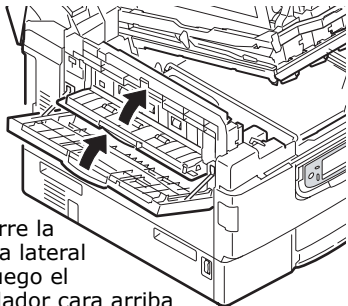

Cierre la
tapa lateral
y luego el
apilador cara arriba

10.

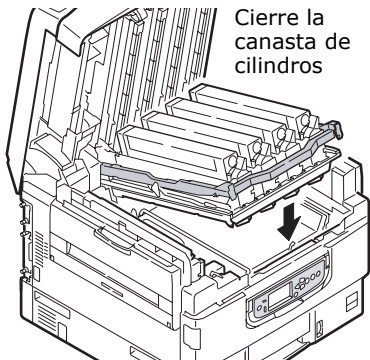

Cierre la
canasta de
cilindros

11.

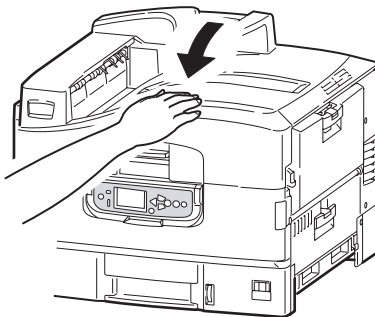

Atascos de papel (Medios)

Unidad duplex

Unidad duplex

1.

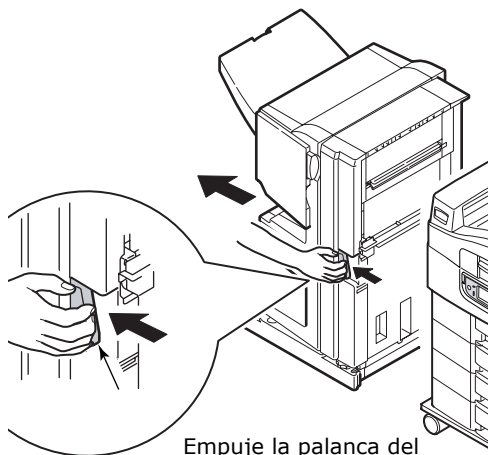

Empuje la palanca del
inversor y sáquelo
fuera de la impresora

2.

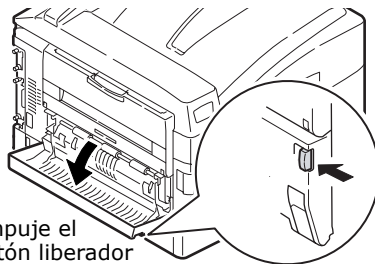

Empuje el
botón liberador
de la tapa de la
unidad duplex y abra la tapa

3.

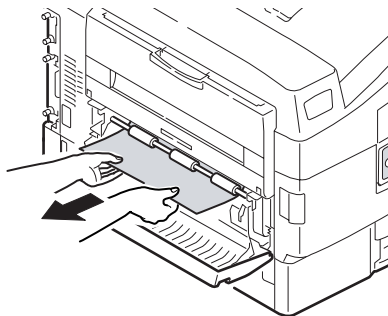

Atascos de papel (Medios)

Unidad duplex (continuación)

4.

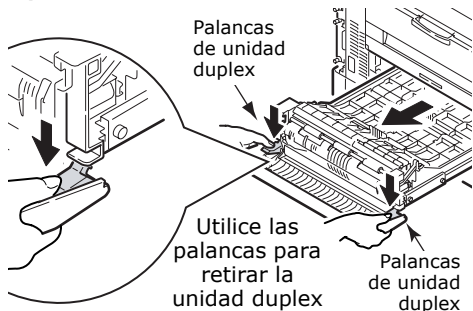

5.

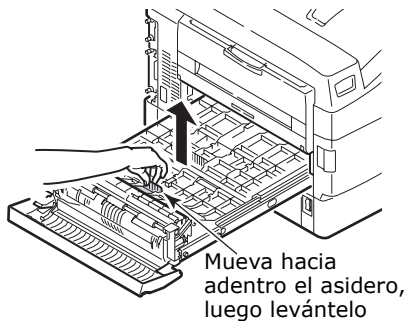

6.

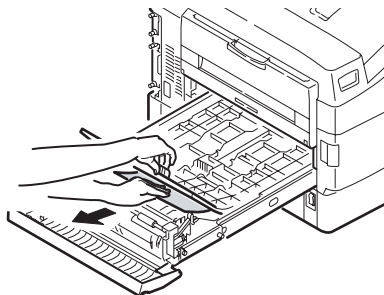

7.

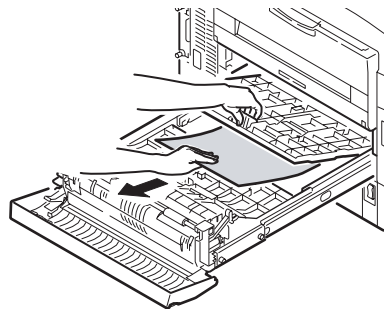

Atascos de papel (Medios)

Unidad duplex (cont.)

8.

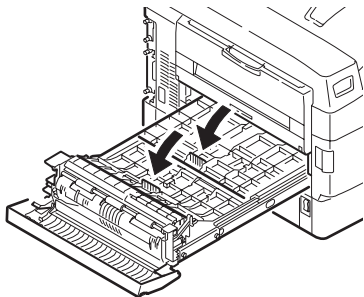

9.

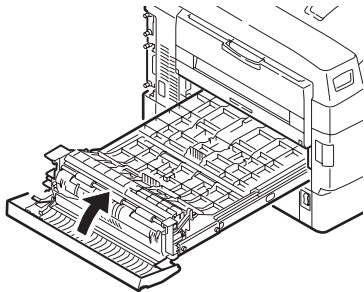

10.

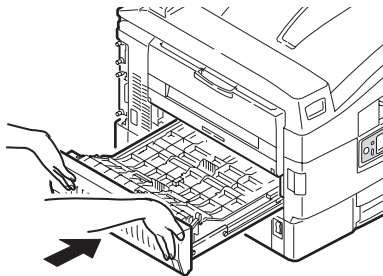

11.

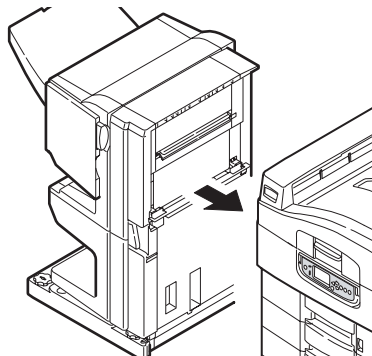

Mantenimiento

Limpieza de la Cabezales LED

Limpieza de la Cabezales LED

Limpie los cabezales LED:

- cada vez que reemplace un cartucho de tóner (los cartuchos de tóner nuevos traen un limpiador de lentes LED)
- si los impresos contienen imágenes desgastadas, barras blancas o letras borrosas

1. Abra la tapa superior.

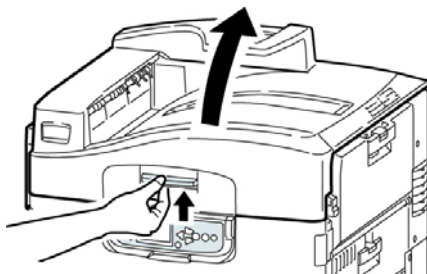

Mantenimiento

Limpieza de la Cabezales LED (continuación)

2. Utilice el limpiador de LED que viene con los cartuchos de tóner o un paño suave sin pelusas para limpiar los cuatro cabezales (1). Mueva el paño como se indica, utilizando una sección limpia del paño con cada pasada. Tenga cuidado de no estropear las guardas (2).

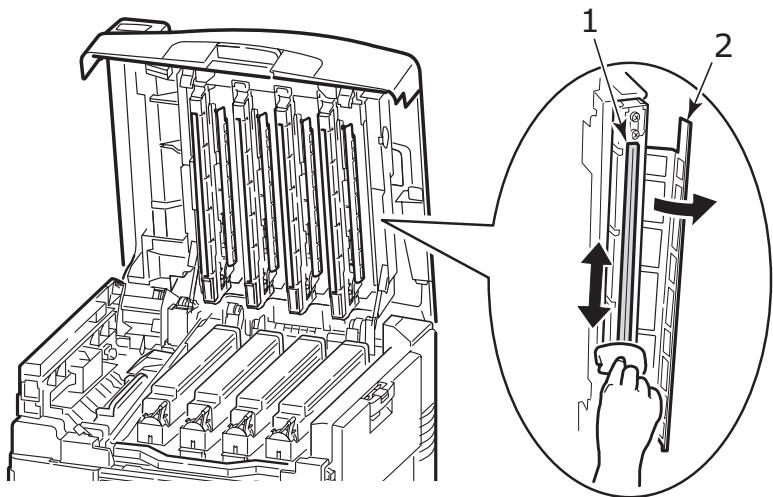

3. Cierre la tapa superior.

Mantenimiento

Limpeza de los rodillos de alimentación de las bandejas de papel

Limpeza de los rodillos de alimentación de las bandejas de papel

1. Primero quítese el reloj o las pulseras para que no se enreden en el mecanismo.



2. Si la impresora tiene instalado un disco duro, pulse y sostenga el botón Shutdown/Reset (Apagar/Reiniciar) del panel de control durante 3 segundos y espere a que aparezca el mensaje que indica que puede apagar la impresora. De lo

contrario proceda con el siguiente paso.



3. Apague la impresora.

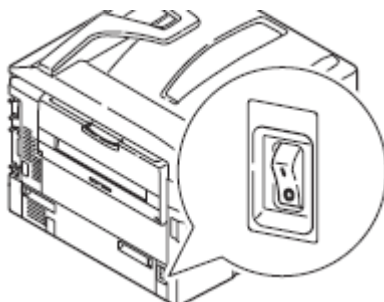

Mantenimiento

Limpieza de los rodillos (continuación)

4. Abra la tapa lateral de la Bandeja 1 y saque el plato de la guía de papel (1).

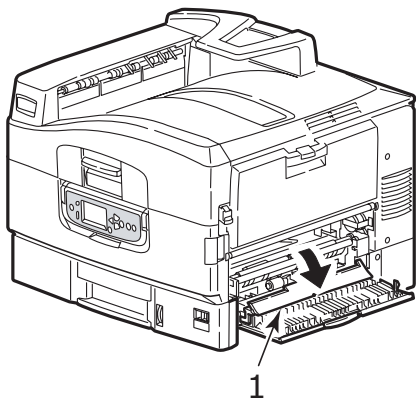

5. Retire la bandeja 1 de la impresora.

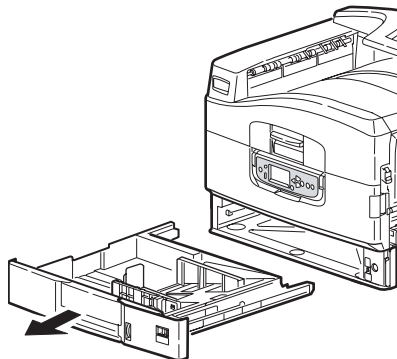

Mantenimiento

Limpieza de los rodillos (cont.)

6. A través del espacio en donde estaba la Bandeja 1, limpie los 3 rodillos de alimentación de papel (2) con un paño suave ligeramente humedecido con agua.

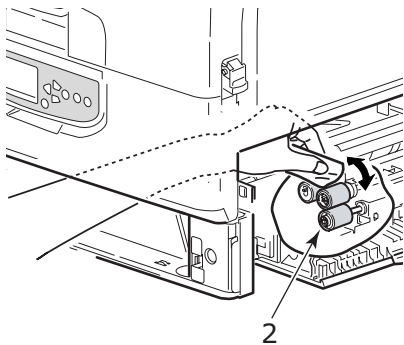

7. Vuelva a colocar la Bandeja 1.

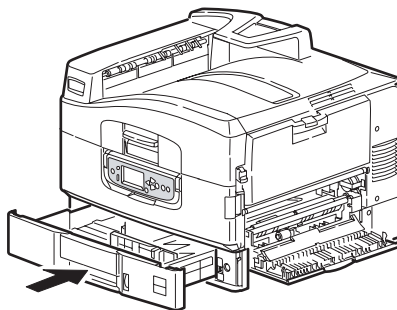

Mantenimiento

Limpieza de los rodillos (cont.)

8. Vuelva a colocar el plato de la guía de papel en su posición inicial y cierre la tapa lateral de la Bandeja 1.

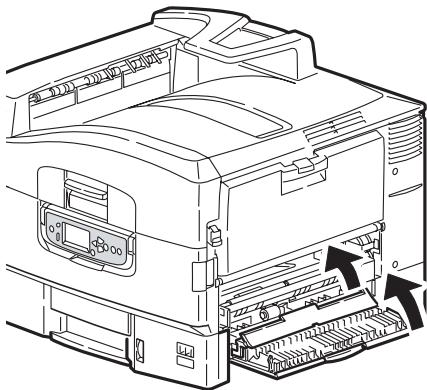

9. Encienda la impresora.

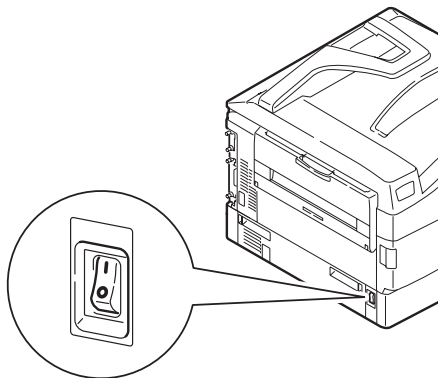

Informes

Cómo imprimir los informes

Cómo imprimir los informes

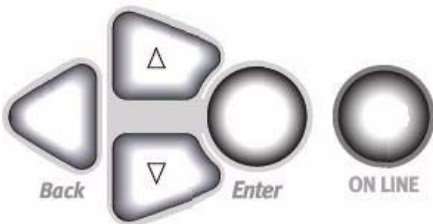

1. Presione **Enter**.
2. Tecla ∇ → **Información de impr.**
Presione **Enter**.
3. Tecla ∇ → informe que desea imprimir:
 - Configuración: información general sobre la configuración de la impresora, además de una lista de la configuración actual del menú.
 - Network (Redes): puede seleccionar la impresión de un resumen de una página o la impresión en varias páginas de la lista de información sobre la red.

- Páge Demo: imprimir una hoja demo.
- Lista de archivos: los archivos almacenados en el disco duro.
- Lista de fuentes PS: Fuentes PostScript de la impresora.
- Lista fuente. PCL: Fuentes PCL de la impresora.
- Lista fuente. IBM PR: Fuentes de emulación IBM ProPrinter para la impresora.
- List.fuente.EPSON FX: Fuentes de emulación Epson FX en la impresora.
- etc. (para mayor información, refiérase a la Guía del Usuario en línea en el CD con documentación que vino con su impresora o en **http://www.okiprintingsolutions.com**)

4. Presione **Enter**.
El informe se imprime y la impresora se coloca en línea.

Mensajes de error el tecla Help

La impresora incluye una ayuda incorporada.

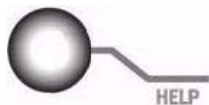

Cuando el mensaje de error aparece, presione HELP. El panel muestra información que le permite corregir el problema.

Utilice el tecla ∇ para investigar la información de Ayuda.

Para mayor información, refiérase a la Guía del Usuario en línea en el CD con documentación que vino con su impresora o en

<http://www.okiprintingsolutions.com>

Información sobre los Servicios de apoyo al cliente

Disponibles 24 horas al día, 7 días una semana

- Visite nuestro sitio Web multilingüe www.okiprintingsolutions.com
- Visite <http://my.okidata.com> (*solo en inglés*)
 - Controladores y utilidades
 - Resolución de problemas
 - Noticias sobre productos
 - ¡y mucho más!
- Favor llamar al:
 - 52-555-263-8780 (Oki Data de México. S.A. de C.V.)
 - 1-856-222-7496 (solo en Español)

OKI es una marca de fábrica registrada de Oki Electric Industry Company, Ltd.

3M es una marca de fábrica o una marca de fábrica registrada de 3M.

Adobe, y PostScript son marcas de fábrica de Adobe Systems, Inc. que pueden estar registradas en ciertas jurisdicciones.

AMEX es una marca de fábrica registrada de American Express Co..

HammerMill es una marca de fábrica registrada de HammerMill.

MasterCard es una marca de fábrica registrada de MasterCard International, Inc..

Xerox es una marca de fábrica de Xerox Corporation.

VISA es una marca de fábrica registrada de Visa.

Wausau Exact es una marca de fábrica registrada de Wausau-Mosinee Paper Corp.

Suprimentos de reposição

Informações para compra, Números dos componentes

Informações para compra

- Consulte o revendedor onde adquiriu a impressora.
- Consulte um representante autorizado de vendas ou assistência técnica da Oki Data. Para se informar a respeito do revendedor mais próximo, ligue para 55-11-3444-6747 (grande São Paulo) ou 0800-11-5577 (demais localidades).
- Consulte os catálogos de suprimentos de escritório

Use Supply Manager (Gerenciador de Suprimentos) da OKI

- Calcula a sua taxa de utilização baseando-se nas informações fornecidas.
- Envia um lembrete por e-mail avisando quando está na hora de fazer outro pedido.

para registrar, visite <http://www.okiprintingsolutions.com>

Números dos componentes

Importante!

Os consumíveis designados "Série C9000" não são compatíveis com esses modelos. *Use apenas cartuchos de toner e cilindros OPC Tipo C7.*

Cartuchos de toner, Tipo C7

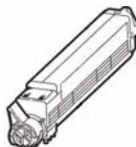

Cor	Número do produto Oki
Preto	42918984
Ciano	42918983
Magenta	42918982
Amarelo	42918981

Suprimentos de reposição

Números dos componentes (continuação)

Cilindros OPC, Tipo C7

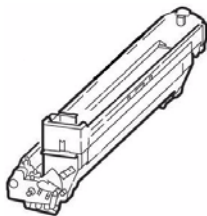

Cor	Número do produto Oki
Preto	42918168
Ciano	42918167
Magenta	42918166
Amarelo.....	42918165

Outros suprimentos

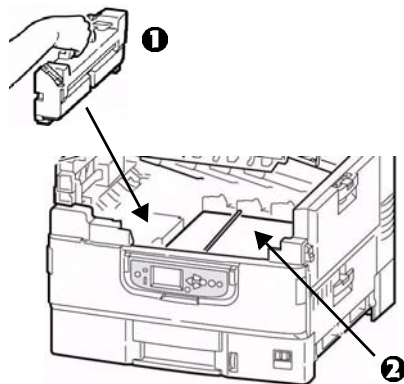

Suprimento	Número do produto Oki
Unidad fusora (1) 42931701, 120V
 42931702, 230V
Esteira de transferência (2) 42931601
Recipiente para resíduos de toner 42869401

Utilização dos menus da impressora

Altere as configurações

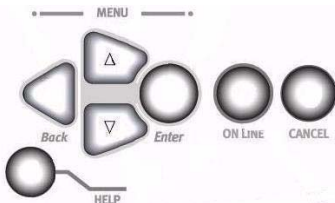
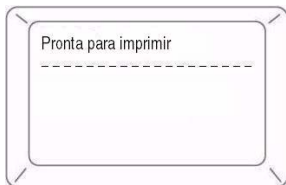

1. Pressione **Enter**.

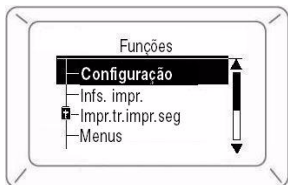

2. Use as tecla ∇ para acessar a função que deseja mudar.
3. Pressione **Enter**.
4. Continue a usar as teclas ∇ e **Enter** para acessar o item que deseja mudar.

5. Use as tecla ∇ para acessar a configuração que deseja acionar.
6. Pressione **Enter**.
Um asterisco () aparecerá ao lado da configuração.*
7. Pressione **ON LINE** para sair do modo Menu.

Para obter mais informações sobre, consulte o Manual Eletrônico do Usuário no CD de documentação fornecido com a impressora ou no site <http://www.okiprintingsolutions.com>

Utilização dos menus da impressora

Resumo dos menus

– Configuração

- Contagem de páginas, Vida útil dos suprimentos
- Configurações da rede e do sistema

– Infs. impr

[Imprimir informações]

- Configurações da impressora e da rede
- Imprime uma página de demonstração
- Listas, etc.

– Impr.tr.impr.sec

[Imprimir trabalho seguro]

(Protegido por senha)

Só aparece se o disco rígido (HDD) (opcional nos modelos C9650n e C9650dn) estiver instalado.

- Impressão de documentos confidenciais transferidas para o Unidade de disco rígido

– Menus

- Configura o tamanho, gramatura e

tipo de material correspondente à bandeja para papel sendo

– Conf. admin. [Configuração da administração] (Protegido por senha)

- Várias configurações de rede
- Configuração de impressão
- Configurações de PS e PCL
- Configurações de IBM e Epson
- Configuração de Cor
- Configurações de Memória e Memória Flash
- Configurações de Unidade de disco rígido e Sistema
- Restabelecer/salvar/restaurar configurações

– Calibração

- Ajustes da densidade
- Registro
- Ajuste das cores

– Estatís. impr. [Imprimir estatísticas] (Protegido por senha)

Utilização dos menus da impressora

Alteração das configurações do papel (mídia)

Por que alterar?

Configurações incorretas do papel podem causar:

- impressão de baixa qualidade
- desprendimento das partículas de toner
- *podem danificar a impressora*

Gramatura da mídia

A configuração padrão da gramatura da mídia de impressão para todas as bandejas é AUTO.

Trabalhos de impressão individuais

As configurações do papel podem ser ajustadas no driver caso esteja usando papel especial para apenas um trabalho de impressão. Coloque o papel na bandeja apropriada (geralmente a bandeja multifuncional). No aplicativo, clique em **Arquivo** → **Imprimir** e ajuste as configurações do papel conforme necessário.

Todos os trabalhos de impressão (Padrões)

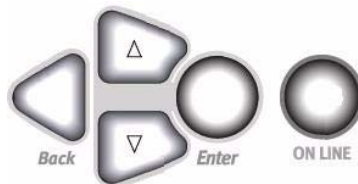

1. Pressione **Enter**.
2. Tecla ∇ → Menus. Pressione **Enter**.
3. Com a opção **Conf. band.** destacada, pressione **Enter**.
4. Tecla ∇ → bandeja a ser configurada. Pressione **Enter**.
5. Use as teclas ∇ e **Enter** para selecionar os submenus e efetuar mudanças nas configurações.
6. Pressione **ON LINE** para sair do modo Menu.

Utilização dos menus da impressora

Alteração das configurações padrão

Restabelecer os padrões de fábrica

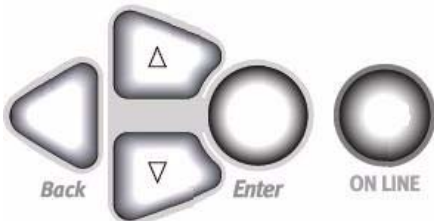

1. Pressione **Enter**.
2. Use as tecla ∇ para acessar **Conf. admin**. Pressione **Enter**.
Digite a senha aparecerá.
3. Use as teclas Δ e ∇ para definir o primeiro dígito da senha. Pressione **Enter**.
Nota: A senha padrão é aaaaaa.
4. Repita as etapas anteriores para cada dígito da senha.

5. Pressione **Enter**.
6. Teclas ∇ \rightarrow **Configurações**. Pressione **Enter**.
7. Destaque **Reinicial. configs**. Pressione **Enter**.
8. Pressione **Enter**.
A impressora é reinicializada e volta para o estado de Pronta para imprimir.

Mídia de impressão

Gramatura do papel

Nota: Para obter informações sobre os parâmetros do papel no que concerne às bandejas de entrada e às áreas de saída, consulte o Manual do Usuário eletrônico no CD de documentação fornecido com a impressora ou visite <http://www.okiprintingsolutions.com>.

Nota: Selecione as configurações apropriadas no menu ou no driver da impressora.

Nota: Configurações do driver da impressora estas cancelam as configurações do menu.

US Bond

Configuração	US Bond (métrico)
Auto (<i>padrão</i>)	17 a 57-lb. (64 a 216 g/m)
Light [Leve]	17-lb. (64 g/m)
Medium Light [Média Leve]	18 a 19-lb. (68 a 71 g/m)
Medium [Média]	20 a 24-lb. (75 a 90 g/m)
Medium Heavy [Média Pesada]	25 a 28-lb. (94 a 105 g/m)
Heavy [Pesado]	29 a 34-lb. (109 a 128 g/m)
Ultra heavy 1 [Ultra pesado 1]	35 a 50-lb. (132 a 188 g/m)
Ultra heavy 2 [Ultra pesado 2]	51 a 58-lb. (192 a 218 g/m)
Ultra heavy 3 [Ultra pesado 3] (<i>Apenas Bandeja MP</i>)	59 a 80-lb. (222 a 301 g/m)

Mídia de impressão

Gramatura do papel (cont.)

Index

Configuração	Index (métrico)
Auto (<i>padrão</i>)	35 a 118.6-lb. (64 a 216 g/m)
Light [Leve]	35-lb. (64 g/m)
Medium Light [Média Leve]	37 a 40-lb. (68 a 71 g/m)
Medium [Média]	42 a 50-lb. (75 a 90 g/m)
Medium Heavy [Média Pesada]	52 a 56-lb. (94 a 105 g/m)
Heavy [Pesado]	60 a 71-lb. (109 a 128 g/m)
Ultra heavy 1 [Ultra pesado 1]	73 a 104-lb. (132 a 188 g/m)
Ultra heavy 2 [Ultra pesado 2]	106 a 141-lb. (192 a 218 g/m)
Ultra heavy 3 [Ultra pesado 3] (<i>Apenas Bandeja MP</i>)	123 a 166-lb. (222 a 301 g/m)

Nota: Para determinar se a gramatura de um papel específico é US Bond ou Index, consulte o equivalente métrico.

Exemplo: 35 lb. *US Bond* = 132 g/m ; 35 lb. *Index* = 64 g/m

Para obter mais informações sobre, visite o site www.paper-paper.com/weight.html (*somente em inglês*).

Mídia de impressão

Carregamento das bandejas 1 a 5

Colocação de mídia de impressão nas bandejas 1 a 5

Para obter mais informações sobre, consulte o Manual Eletrônico do Usuário no CD de documentação fornecido com a impressora ou no site <http://www.okiprintingsolutions.com>

1.

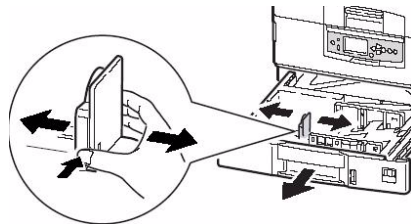

2.

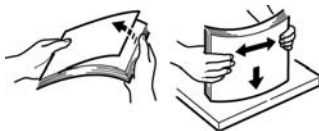

3. Lado de impressão *para baixo*:

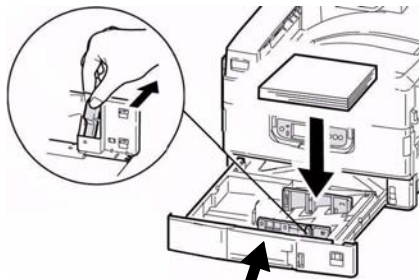

Nota: Para papel timbrando:

Alimentação no sentido da borda longa—
face de impressão para baixo, parte superior voltada para trás da impressor.

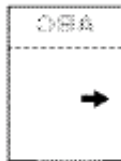

Alimentação no sentido da borda curta—
face de impressão para baixo, parte superior à direita:

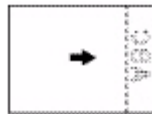

Mídia de impressão

Carregamento da bandeja multifuncional

Colocação de mídia de impressão na bandeja multifuncional

Para obter mais informações sobre, consulte o Manual Eletrônico do Usuário no CD de documentação fornecido com a impressora ou no site <http://www.okiprintingsolutions.com>

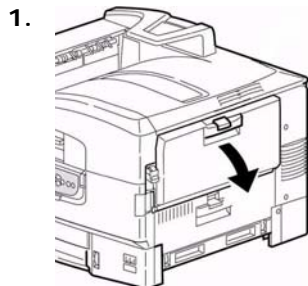

2.

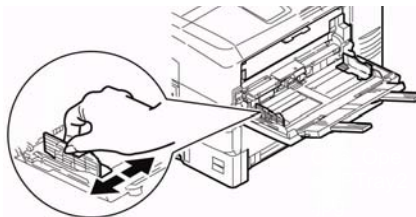

3.

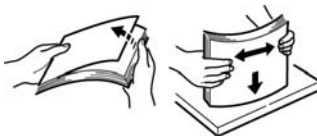

4. Lado de impressão *para cima*.

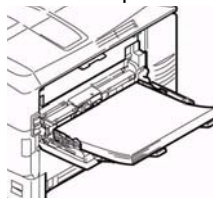

Mídia de impressão

Carregamento da bandeja multifuncional (cont.)

Nota: Papel timbrando (Carta, A4 ou B5):

Alimentação no sentido da borda longa—posicionar o timbre voltado para a parte traseira da impressora:

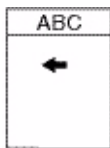

Alimentação no sentido da borda curta—posicionar o timbre no sentido da entrada para o papel da impressora:

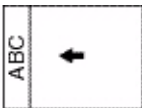

Nota: Transparências e Etiquetas:

- Lado de impressão *para cima*.
- Padrão = alimentação no sentido da borda longa.

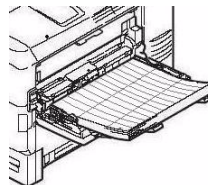

Envelopes:

- Orelha para *baixo*, voltada para a entrada para papel da impressora:

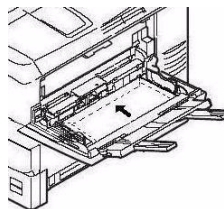

Percursos de saída

Face para baixo (Saída superior)

Esta é a bandeja normalmente usada.

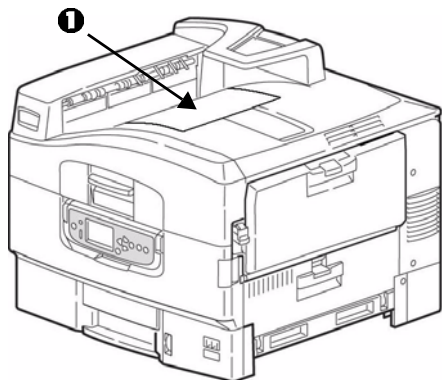

As bandeja têm uma capacidade para até 500 folhas de papel de 20-lb. (75 g/m).

O escaninho de saída com a face de impressão para cima (ver próxima página) deve ser usado para papéis especiais ou de alta gramatura.

Percursos de saída

Face de impressão para cima (Saída lateral)

O percurso para o escaninho de saída lateral (face de impressão para cima) é reto. Use um percurso reto para imprimir transparências, etiquetas, papéis espessos, ou para imprimir a partir da Bandeja MP. As bandeja têm uma capacidade para até 200 folhas de papel de 20-lb. (75 g/m).

Ao abrir a face de impressão para cima

1.

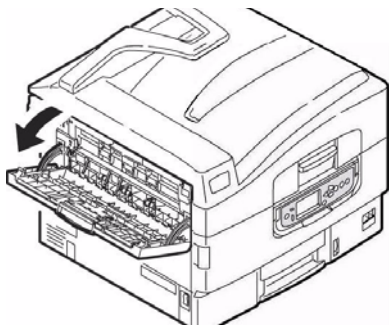

2.

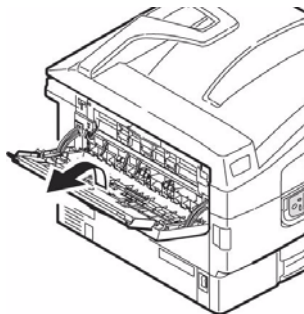

3.



Mídia de impressão recomendada

Papel, Cartão

Mídia	Recomendada
Papel	<p>Carta:</p> <ul style="list-style-type: none">• OKI® 52208001 Bright White, 32-lb. US Bond• HammerMill® Laser Print Radiant, branco, 24-lb. US Bond• Xerox® 4024, 20-lb. US Bond <p>Tablóide/Tablóide Extra:</p> <ul style="list-style-type: none">• Oki 52206102, 52206103 Bright White, 32-lb. US Bond• HammerMill Laser Print Radiant, branco, 24-lb. US Bond <p>Faixas:</p> <ul style="list-style-type: none">• Oki 52207901, 8.5" x 35.4", 32-lb. US Bond, 25 folhas• Oki 52206002, 8.5" x 35.4", 32-lb. US Bond, 100 folhas• Oki 52206001, 12.9" x 35.4", 32-lb. US Bond, 100 folhas
Papel de alta gramatura (Cartão)	<p>Carta:</p> <ul style="list-style-type: none">• Oki 52205601 Papel cartão da série• Wausau Exact Index: 49108 (90-lb.) ou 49508 (110-lb.) <p><i>Para evitar danificar a impressora, é muito importante verificar as configurações de mídia de impressão antes de imprimir em papéis espessos.</i></p>

Mídia de impressão recomendada

Etiquetas, Envelopes, Transparências

Mídia	Recomendada
Etiquetas	<p>Carta: Avery® 5161</p> <p>A4: Avery 7162, 7664, 7666</p> <p><i>Use etiquetas designadas para impressoras a laser. As etiquetas devem cobrir toda a folha de base.</i></p>
Envelopes	<p>COM-10: Oki 52206301, 52206302</p> <p><i>Para obter melhores resultados de impressão, use apenas os envelopes recomendados. Nunca use envelopes com fechos de metal, botões de pressão, janelas ou abas com vedação em V.</i></p>
Transparências	<p>Carta:</p> <ul style="list-style-type: none">• Oki 52205701• 3M® CG3720 <p><i>Para obter melhores resultados de impressão, use apenas as transparências recomendadas. Nunca use transparências comerciais destinadas a uso manual com canetas de ponta porosa. Elas derreterão na unidade fusora e causarão danos.</i></p>

Atolamentos de mídia

Em geral

Se o mídia ficar atolado com frequência, verifique os seguintes itens.

- A impressora está nivelada?
- O meio de impressão utilizado está dentro das especificações? Papéis de gramatura muito baixa ou muito alta geralmente causam atolamentos.
- As configurações (impressora e driver) são apropriadas para o meio de impressão usado?
- Não use papel amarrotado ou enrolado.
- Retire o papel da bandeja. Ventile/alinhe a pilha. Troque o papel.

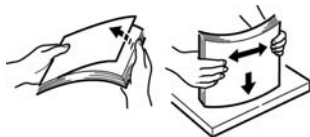

- Os envelopes estão ficando atolados. Certifique-se de que a

pilha esteja alinhada corretamente. Os envelopes devem ser colocados com as orelhas para baixo e a borda superior voltada para a impressora.

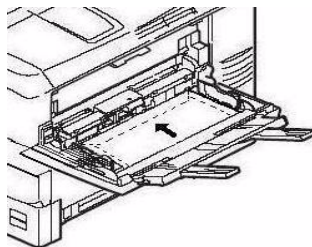

- Limpe o cilindro de alimentação (veja página 134).

Nota: for more information, para obter mais informações sobre, consulte o Manual Eletrônico do Usuário no CD de documentação fornecido com a impressora ou no site <http://www.okiprintingsolutions.com>

Atolamentos de mídia

Tampa lateral da bandeja

Tampa lateral da bandeja

1.

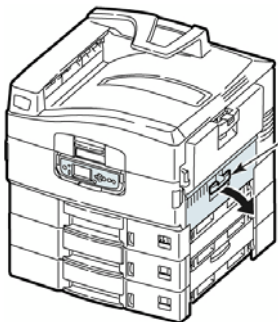

Aperte a
trava e
abra a
tampa

2.

Segure a lingüeta e vire a
guia do papel para fora

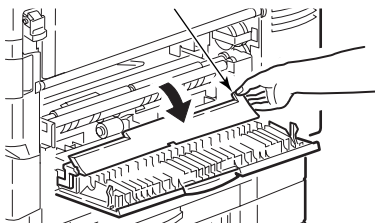

3.

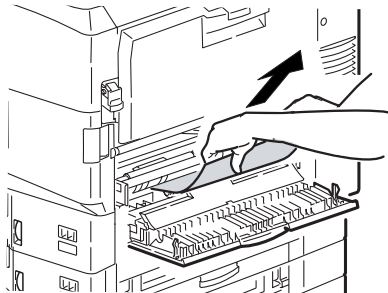

4.

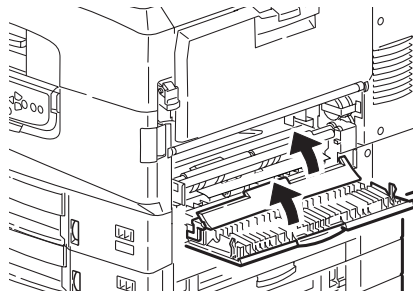

Atolamentos de mídia

Tampa lateral da impressora

Tampa lateral da impressora

1.

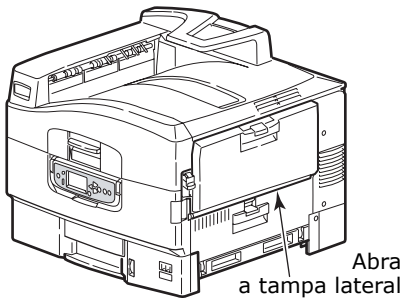

2.

Puxe a trava e abra a tampa lateral

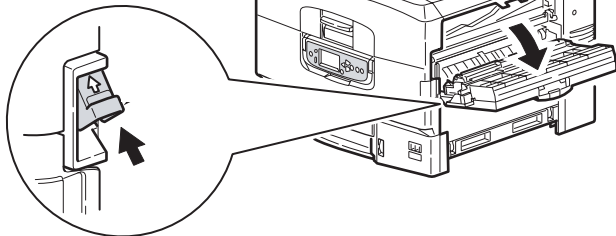

3.

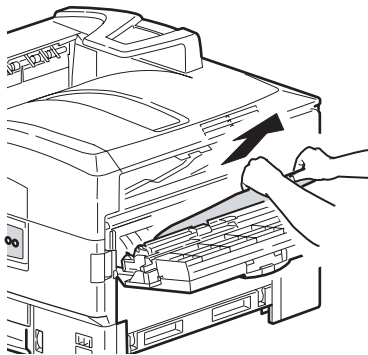

4.

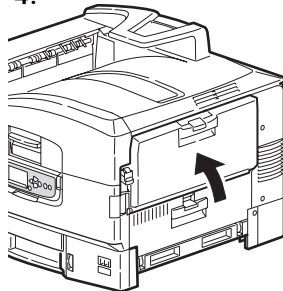

Atolamentos de mídia

Tampa superior da impressora

Tampa superior da impressora

1. Aperte o pegador da tampa superior

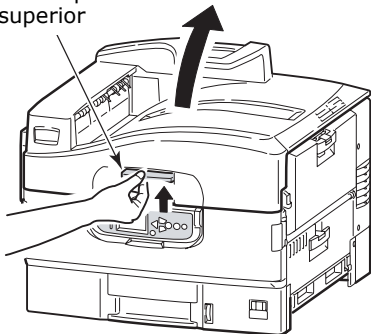

ATENÇÃO!

Não toque na unidade fusora, pois pode estar quente depois da impressão.

- 2.

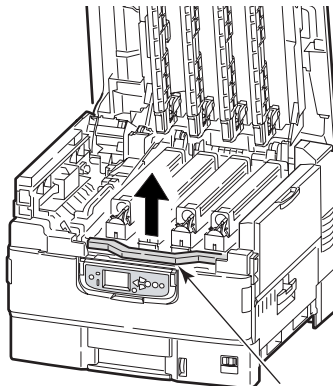

Aperte o pegador da cesta e levante a cesta de cilindros OPC

- 3.

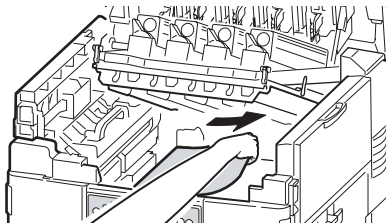

Atolamentos de mídia

Tampa superior da impressora (cont.)

ATENÇÃO! Não toque na unidade fusora, pois pode estar quente depois da impressão. Se a unidade fusora estiver quente, aguarde até que esfrie antes de tentar remover o papel atolado.

4.

Unidade fusora

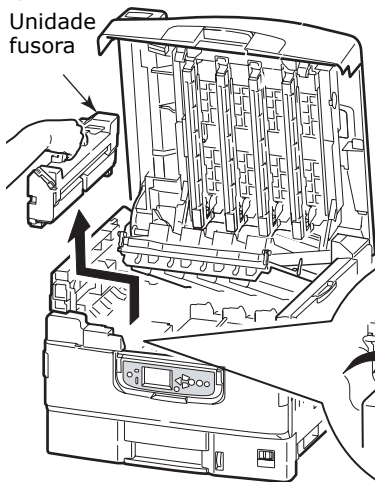

Empurre a alavanca da trava



5. Puxe para cima as alavancas de liberação para soltar o papel

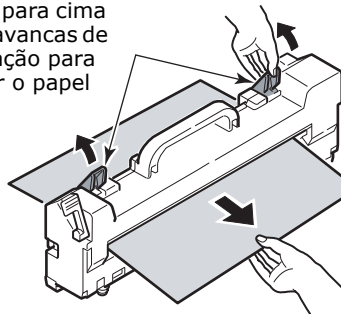

Atolamentos de mídia

Tampa superior da impressora (cont.)

6.

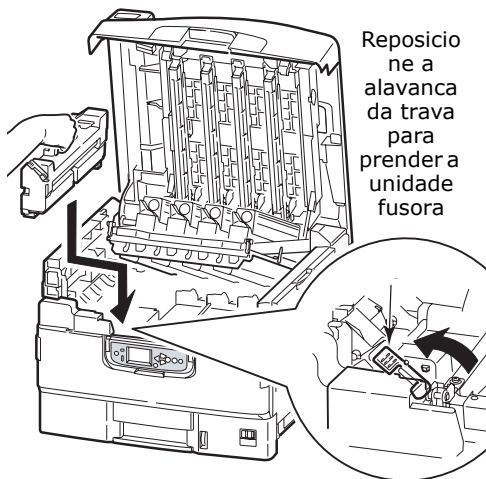

7.

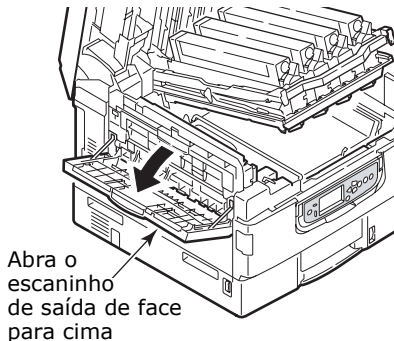

8.

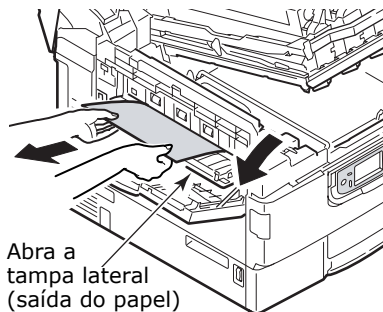

Atolamentos de mídia

Tampa superior da impressora (cont.)

9.

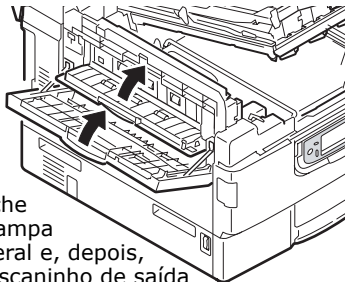

Feche a tampa lateral e, depois, o escaninho de saída de face para cima

10.

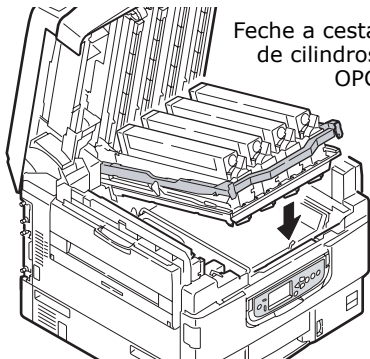

Feche a cesta de cilindros OPC

11.

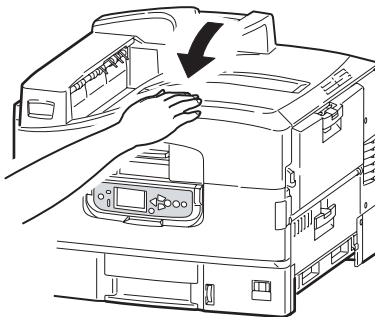

Atolamentos de mídia

Unidade duplex

Unidade duplex

1.

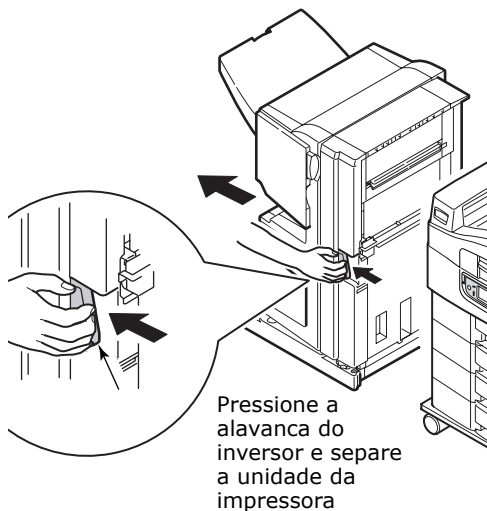

2.

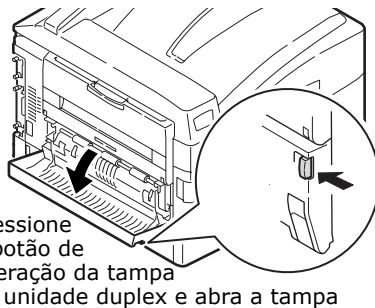

3.

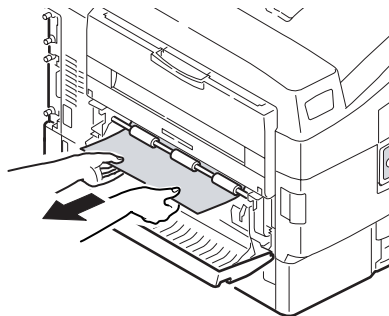

Atolamentos de mídia

Unidade duplex (cont.)

4.

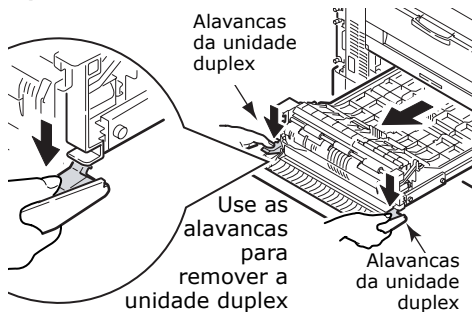

5.

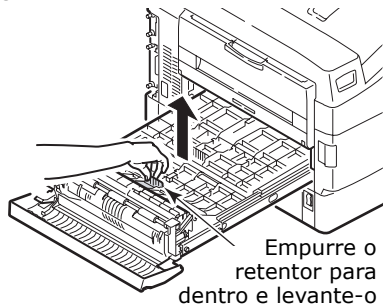

6.

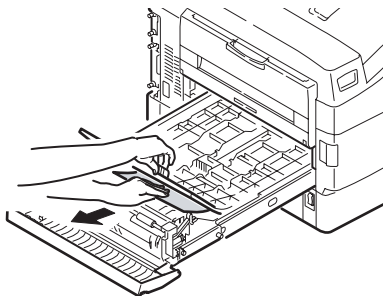

7.

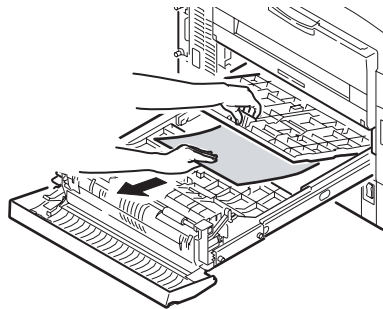

Atolamentos de mídia

Unidade duplex (cont.)

8.

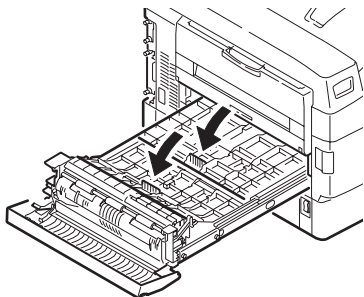

9.

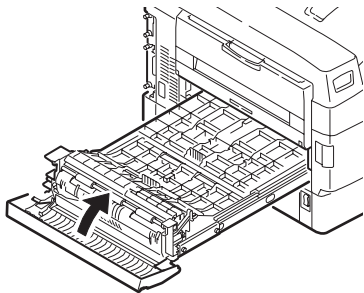

10.

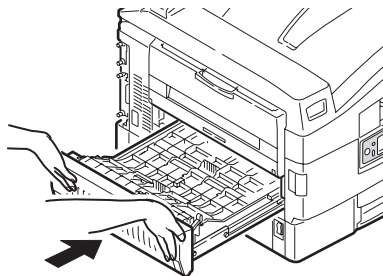

11.

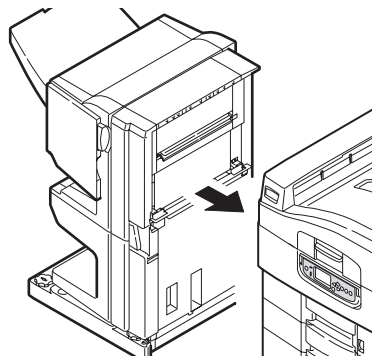

Manutenção

Limpeza do pente de LEDs

Limpeza do pente de LEDs

Limpe os cabeçotes dos pentes de LED:

- sempre que um cartucho de toner for trocado (um limpador de pente de LEDs é fornecido com cada cartucho de toner de reposição)
- se as folhas impressas exibirem sinais de imagens esvanecidas, faixas brancas ou letras borradas

1. Abra a tampa superior.

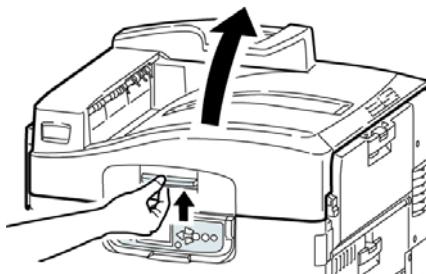

Manutenção

Limpeza do pente de LEDs (cont.)

2. Use o limpador de pente de LEDs fornecido com os cartuchos de toner ou um pano macio sem fiapos para limpar com cuidado os quatro pentes (1). Aplique o limpador como ilustrado, usando uma parte limpa do aplicador a cada passada. Tenha cuidado para não danificar os protetores (2).

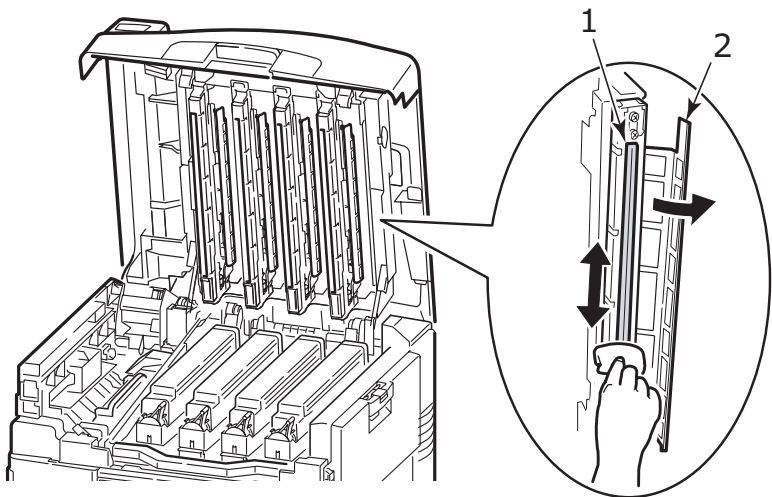

3. Feche a tampa superior.

Manutenção

Limpeza dos roletes de alimentação da bandeja para papel

Limpeza dos roletes de alimentação da bandeja para papel

1. Retire artigos como relógios ou braceletes para que não se prendam no mecanismo.



2. Se um disco rígido estiver instalado na impressora, pressione e mantenha pressionado o botão Shutdown/Reset no painel de controle por 3 segundos e aguarde até o display exibir uma mensagem informando que a impressora pode

ser desligada. Caso contrário, vá para a próxima etapa.



3. Desligue a impressora.

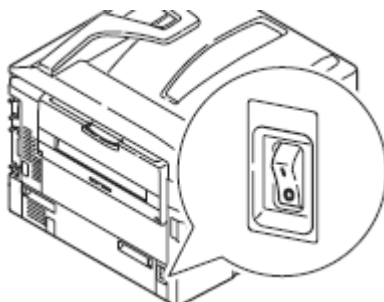

Manutenção

Limpeza dos roletes de alimentação da bandeja para papel (cont.)

4. Abra a tampa lateral da bandeja 1 e puxe a placa da guia do papel para fora (1).

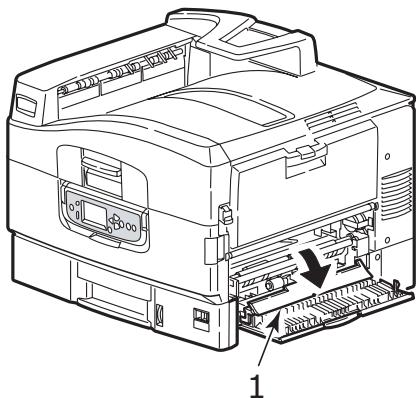

5. Retire a bandeja 1 da impressora.

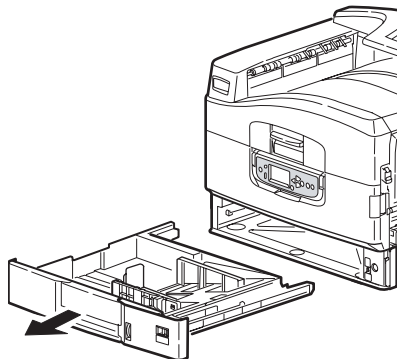

Manutenção

Limpeza dos roletes de alimentação da bandeja para papel (cont.)

6. Use o espaço deixado pela remoção da bandeja 1 para limpar os 3 roletes de alimentação do papel (2) com um pano macio ligeiramente umedecido com água.

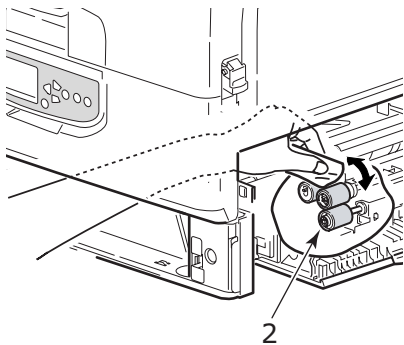

7. Recoloque a bandeja 1.

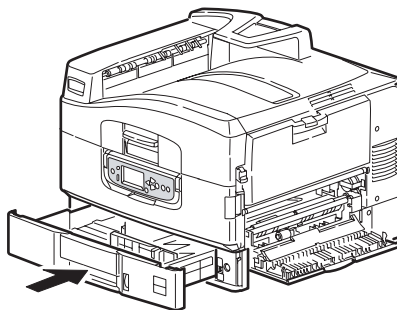

Manutenção

Limpeza dos roletes de alimentação da bandeja para papel (cont.)

8. Recoloque a placa da guia do papel em sua posição original e feche a tampa lateral da bandeja 1.

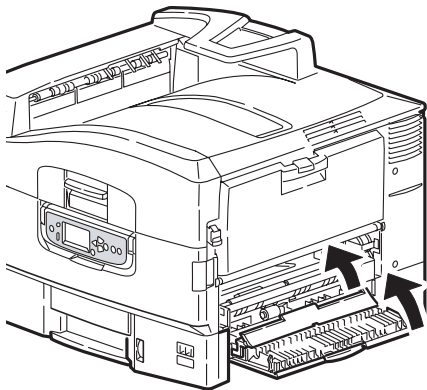

9. Ligue a impressora.

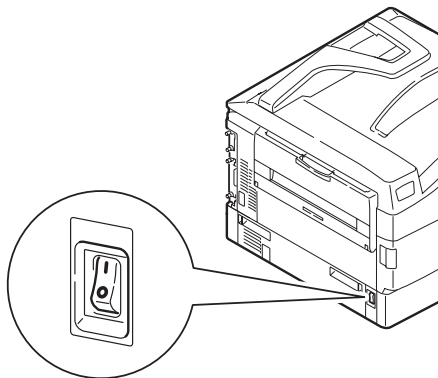

Relatórios

Impressão de relatórios

Impressão de relatórios

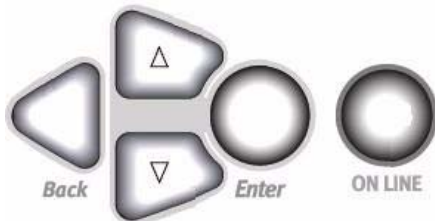

1. Pressione **Enter**.
2. Tecla ∇ → **Infs. impr.** Pressione **Enter**.
3. Tecla ∇ → relatório que deseja imprimir:
 - Configuração: informações gerais sobre a configuração da impressora e uma lista das configurações dos menus.
 - Network: escolha a impressão de um resumo de uma página ou uma lista detalhada de várias páginas com as informações da rede.

- Página de amostra: Imprime a página de demonstração.
 - Lista de arquivos: arquivos armazenados na unidade de disco rígido interna da impressora.
 - Lista de fontes PS: Fontes PostScript na impressora.
 - Lista de fontes PCL: Fontes PCL na impressora..
 - Lst.ftes.IBM PPR: Fontes de emulação IBM ProPrinter na impressora..
 - Lst.ftes.EPSON FX: Fontes de emulação Epson FX na impressora.
 - etc. (para obter mais informações, consulte o Manual Eletrônico do Usuário no CD de documentação fornecido com a impressora ou no site <http://www.okiprintingsolutions.com>).
4. Pressione **Enter**.
O relatório é impresso e a impressora volta a ficar em linha.

Mensagens de erro

Botão Help

A impressora possui um sistema de Ajuda.

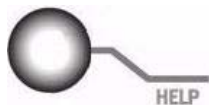

Quando uma mensagem de erro for exibida, pressione HELP. O visor mostra informações que ajudarão a corrigir o erro.

Use as tecla ▾ para acessar mais informações da Ajuda.

Para obter mais informações sobre, consulte o Manual Eletrônico do Usuário no CD de documentação fornecido com a impressora ou no site <http://www.okiprintingsolutions.com>

Informações sobre assistência técnica

Disponíveis 24 horas por dia, 7 dias por semana

- Visite o nosso web site multilíngüe no endereço www.okiprintingsolutions.com
- Visite o site <http://my.okidata.com> (*somente em inglês*)
 - drivers e utilitários
 - diagnóstico e resolução de problemas
 - notícias sobre produtos
 - e muito mais!
- Ligue para 55-11-3444-6747 (São Paulo y otras ciudades con código de área 11) ou 0800-11-5577 (demás ciudades).

OKI é uma marca registrada da Oki Electric Industry Company, Ltd.

3M é uma marca comercial ou marca registrada da 3M Company.

Adobe e PostScript são marcas comerciais da Adobe Systems, Inc., que podem estar registradas em certas jurisdições.

AMEX é uma marca registrada da American Express Co.

HammerMill é uma marca registrada da HammerMill.

MasterCard é uma marca registrada da MasterCard International, Inc.

VISA é uma marca registrada da Visa.

Xerox é uma marca comercial da Xerox Corporation.

Wausau Exact é uma marca registrada da Wausau-Mosinee Paper Corp.