

# **User's Guide**

# Copyright Information

---

Copyright © 2009 by Oki Data. All Rights Reserved

C710n User's Guide

P/N 59308901, Revision 1.2

August, 2009

## **Disclaimer**

Every effort has been made to ensure that the information in this document is complete, accurate, and up-to-date. The manufacturer assumes no responsibility for the results of errors beyond its control. The manufacturer also cannot guarantee that changes in software and equipment made by other manufacturers and referred to in this guide will not affect the applicability of the information in it. Mention of software products manufactured by other companies does not necessarily constitute endorsement by the manufacturer.

While all reasonable efforts have been made to make this document as accurate and helpful as possible, we make no warranty of any kind, expressed or implied, as to the accuracy or completeness of the information contained herein.

The most up-to-date drivers and manuals are available from the web site:

<http://www.okiprintingsolutions.com>

## **Trademark Information**

Oki and Oki Data are registered trademarks of Oki Electric Industry Company Ltd.

Apple, Macintosh and Mac OS are registered trademarks of Apple Computers Inc.

Hewlett-Packard, HP, and LaserJet are registered trademarks of Hewlett-Packard Company.

Microsoft, MS-DOS and Windows are either registered trademarks or trademarks of Microsoft Corporation in the United States and/or other countries.

Other product names and brand names are registered trademarks or trademarks of their proprietors.

# Contents

---

<b>Copyright Information</b> . . . . .	<b>2</b>
Notes, Cautions and Warnings . . . . .	5
<b>Introduction</b> . . . . .	<b>6</b>
Printer Overview . . . . .	8
Front View . . . . .	8
Rear View . . . . .	9
Changing the display language . . . . .	10
<b>Paper Recommendations</b> . . . . .	<b>11</b>
Tray 1 and Optional Trays 2 and 3 . . . . .	11
Media sizes . . . . .	11
Media Weight Ranges . . . . .	12
Media Weight Settings . . . . .	12
Multi purpose tray . . . . .	12
Face down stacker . . . . .	13
Face up stacker . . . . .	13
Duplex unit . . . . .	13
<b>Loading paper</b> . . . . .	<b>14</b>
Tray 1 and Optional Trays 2 and 3 . . . . .	14
Multi-Purpose Tray . . . . .	18
<b>Menu functions</b> . . . . .	<b>21</b>
Operator Panel: . . . . .	21
How to Change the Settings: User . . . . .	23
How to Change the Settings: Administrator . . . . .	24
Configuration Menu . . . . .	25
Print Information Menu . . . . .	26
Print Secure Job Menu . . . . .	27
Menus Menu . . . . .	29
Shutdown menu . . . . .	33
Admin Setup . . . . .	33
Calibration . . . . .	50
Print Statistics . . . . .	52
Administrator (Boot) Menu . . . . .	53
Parallel Setup . . . . .	53
USB Setup. . . . .	54
Security Setup . . . . .	55
Storage System . . . . .	55
Power Setup . . . . .	57
Language Setup . . . . .	57

# Contents

---

<b>Available Options</b> . . . . .	<b>58</b>
Duplex (two-sided printing) Unit . . . . .	58
Additional RAM Memory . . . . .	58
Hard Disk Drive . . . . .	59
Additional Paper Tray(s) . . . . .	59
<b>Clearing Paper Jams</b> . . . . .	<b>60</b>
Major Printer Components and Paper Path . . . . .	60
Paper Sensor Error Codes . . . . .	61
<b>Replacing Consumables and Maintenance Items</b> . . . . .	<b>73</b>
Order Information . . . . .	73
Toner Cartridge Replacement . . . . .	74
Image Drum Replacement . . . . .	80
Replacing the Transfer Belt Unit . . . . .	85
Fuser Replacement . . . . .	91
Cleaning the LED Head . . . . .	94
<b>Utilities</b> . . . . .	<b>96</b>
Summary of Utilities Provided . . . . .	96
Utilities on the CD . . . . .	96
Utilities on the Web (Windows Only) . . . . .	97
Installing the Utilities . . . . .	98
<b>Specifications</b> . . . . .	<b>99</b>

# Notes, Cautions and Warnings

## **Note:**

A note appears in this manual like this. A note provides additional information to supplement the main text which may help you to use and understand the product.

## **CAUTION!**

**A caution appears in this manual like this. A caution provides additional information which, if ignored, may result in equipment malfunction or damage.**

## **WARNING!**

**A warning appears in this manual like this. A warning provides additional information which, if ignored, may result in a risk of personal injury.**

# Introduction

---

Your printer includes these features:

- High quality, multi-level technology produces more subtle tones and smoother gradations of color to lend photographic quality to your documents;
- Up to 30 pages per minute in full color for fast printing of high impact color presentations and other documents;
- Up to 32 pages per minute in black and white for fast and efficient printing of all general purpose documents not requiring color;
- 600 x 600, 1200 x 600 dpi (dots per inch) and high quality print resolution for high quality image production showing the finest detail;
- Internet Protocol version 6 (IPv6)
- Single Pass color Digital LED technology for high speed processing of your printed pages;
- PostScript 3, PCL 5C, PCL 6 and Epson FX emulations for industry standard operation and wide compatibility with most computer software;
- 10Base-T and 100Base-TX network connection lets you share this valuable resource among users on your office network;
- Photo Enhance mode to improve printouts of photographic images (Windows PCL driver only);
- various utilities provided on the CD supplied with the printer: see Utilities, on page 93.
- 530 letter-size sheet main paper tray capacity.

Additionally, the following optional features are also available:

- Automatic two-sided (duplex) printing for economical use of paper and compact printing of larger documents (standard on dn models);
- Additional paper tray for loading a further 530 sheets to minimize operator intervention, or different paper stocks for letterhead stationery, alternative paper sizes or other print media;

- Additional memory allows printing of more complex pages. For example, high resolution banner printing;
- Internal hard disk drive for storage of overlays, macros and downloadable fonts, and automatic collation of multiple copies of multipage documents and the download of ICC Profiles.

# Printer Overview

## Front View

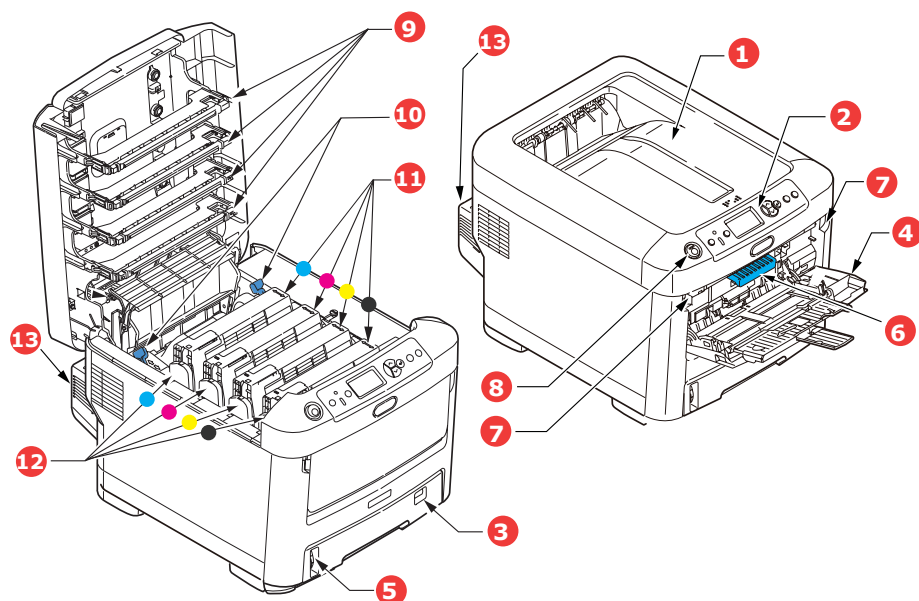

**1. Output stacker, face down.**

Standard printed copy delivery point. Holds up to 350 sheets at 80g/m<sup>2</sup>.

**2. Operator panel.**

Menu driven operator controls and LCD display\* panel.

**3. Paper tray.**

Standard paper tray. Holds up to 530 sheets of 80g/m<sup>2</sup> paper.

**4. Multi purpose tray.**

Used for feeding heavier paper stocks, envelopes and other special media. Also for manual feeding of single sheets when required.

**5. Paper level indicator.**

**6. Front cover release lever.**

**7. Multi-purpose tray release recess.**

**8. Top cover release button.**

**9. LED heads.**

**10. Fuser release levers.**

**11. Toner cartridges (C,M,Y,K).**

**12. ID units (C,M,Y,K).**

**13. Duplex unit (when fitted).**

\*The LCD display language can be changed to show different languages. (see ["Changing the display language" on page 10](#)).



## Rear View

This view shows the connection panel, the rear output stacker and the location of the optional duplex (two-sided printing) unit.

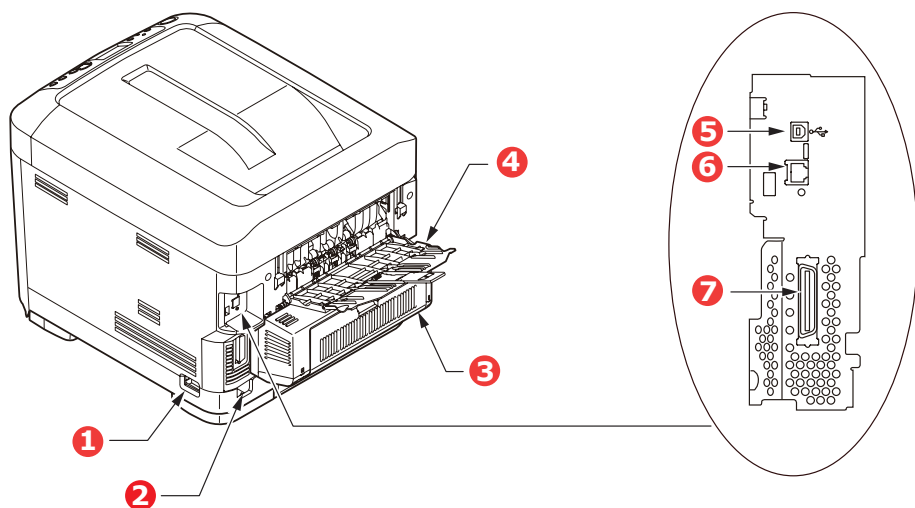

**1. ON/OFF switch.**

**2. AC power socket.**

**3. Duplex unit (when fitted).**

**4. Rear, face up stacker.**

**5. USB interface.**

**6. Network interface.\***

**7. Parallel interface.**

\* The Network Interface may have a protective "plug" which must be removed before connection can be made.

When the rear paper stacker is folded down paper exits the printer through the rear of the printer and is stacked here face up. This is mainly used for heavy print media. When used in conjunction with the multi purpose feed tray, the paper path through the printer is essentially straight. This avoids bending the paper around curves in the paper path and enables feeding of up to 220 g/m<sup>2</sup> media.

## Changing the display language \_\_\_\_\_

The default language used by your printer for display messages and for report printing is English. If required, this can be changed to:

- French
- Spanish
- Portuguese

# Paper Recommendations

---

Your printer will handle a variety of print media, including a range of paper weights and sizes, transparencies and envelopes. This section provides general advice on choice of media, and explains how to use each type.

The best performance will be obtained when using standard 20-lb. (75 g/m<sup>2</sup>) paper designed for use in copiers and laser printers.

Use of heavily embossed or very rough textured paper is not recommended.

**Pre-printed stationery** can be used, but the ink must not offset when exposed to the high fuser temperatures used in the printing process.

**Envelopes** should be free from twist, curl or other deformations. They should also be of the rectangular flap type, with glue that remains intact when subjected to hot roll pressure fusing used in this type of printer. Window envelopes are not suitable.

**Transparencies** should be of the type designed for use in copiers and laser printers. In particular, avoid office transparencies designed for use by hand with marker pens. These will melt in the fuser and cause damage.

**Labels** should also be of the type recommended for use in copiers and laser printers, in which the base carrier page is entirely covered by labels. Other types of label stock may damage the printer due to the labels peeling off during the printing process.

## Tray 1 and Optional Trays 2 and 3

### Media sizes

- Letter
- Legal 13 inch, 13.5 inch, 14 inch
- Executive
- A4, A5
- A6: tray 1 only
- B5
- Custom Sizes: 5.5" to 8.5 inches wide x 8.3" to 14" long. Custom sizes must be predefined in the driver.

## Media Weight Ranges

- Tray 1: 17-50 lb. US Bond (64-188 g/m<sup>2</sup>)
- Optional Trays 2 and 3: 17-54 lb. US Bond (64-203 g/m<sup>2</sup>)

## Media Weight Settings

These settings can be made in the printer menu or in the printer driver. Settings made in the drive override settings made in the menu.

- Light: 17-19 lb. US Bond (64-74 g/m<sup>2</sup>)
- Medium Light: 20-21 lb. US Bond ( 75-82 g/m<sup>2</sup>)
- Medium: 22-30 lb. US Bond (83-104 g/m<sup>2</sup>)
- Heavy: 28-32 lb. US Bond (105-120 g/m<sup>2</sup>)
- Ultra Heavy1 (Tray 1): 32-50 lb. US Bond (121-188 g/m<sup>2</sup>)
- Ultra Heavy2
  - (Tray 2): 32-54 lb. US Bond (121-203 g/m<sup>2</sup>)
  - MP Tray: 32-58 lb. US Bond (189-220 g/m<sup>2</sup>)

If you have identical paper stock loaded in another tray (2nd or 3rd tray if you have one, or multi purpose tray) you can set the printer to automatically switch to the other tray when the current tray runs out of paper. When printing from Windows applications, this function is enabled in the driver settings. When printing from other systems, this function is enabled in the Print Menu. (See ["Menu functions" on page 21.](#))

## Multi purpose tray ---

The multi purpose tray can handle the same sizes as trays 1, 2 and 3 but in weights up to 58 lb. US Bond (220 g/m<sup>2</sup>). For very heavy paper stock use the face up (rear) paper stacker. This ensures that the paper path through the printer is almost straight.

The multi purpose tray can feed paper widths as small as 3 inches (76 mm) and lengths up to 47.25 inches (1220 mm) (banner printing).

For paper lengths exceeding Legal 14-inch (356 mm) use paper stock between bond US de 28 lb. (90 g/m<sup>2</sup>) and bond US de 32 lb. (128 g/m<sup>2</sup>) and the face up (rear) paper stacker.

Use the multi purpose tray for printing on envelopes and transparencies. Up to 50 sheets of transparencies or 10 envelopes

can be loaded at one time, subject to a maximum stacking depth of about 3/8-inch (10 mm).

Paper or transparencies should be loaded print side up and top edge into the printer. Do not use the duplex (two-sided printing) function.

## Face down stacker ---

The face down stacker on the top of the printer can hold up to 350 sheets of 20-lb. US Bond (75 g/m<sup>2</sup>) standard paper, and can handle paper stocks up to 47-lb. US Bond (176 g/m<sup>2</sup>). Pages printed in reading order (page 1 first) will be sorted in reading order (last page on top, facing down).

## Face up stacker ---

The face up stacker at the rear of the printer should be opened and the tray extension pulled out when required for use. In this condition paper will exit via this path, regardless of driver settings.

The face up stacker can hold up to 100 sheets of 20-lb. US Bond (75 g/m<sup>2</sup>) standard paper, and can handle stocks up to 58 lb. US Bond (220 g/m<sup>2</sup>).

Always use this stacker and the multi purpose feeder for paper stocks heavier than 47 lb. US Bond (176 g/m<sup>2</sup>).

## Duplex unit ---

This option provides automatic two-sided printing on the same range of paper sizes as tray 2 (i.e. all cassette sizes except A6), using paper stocks from 20-28 lb. US Bond (75-120 g/m<sup>2</sup>).

**Note:**

The duplex unit comes as standard with dn models.

# Loading paper

---

## Tray 1 and Optional Trays 2 and 3

1. Remove the paper tray from the printer.

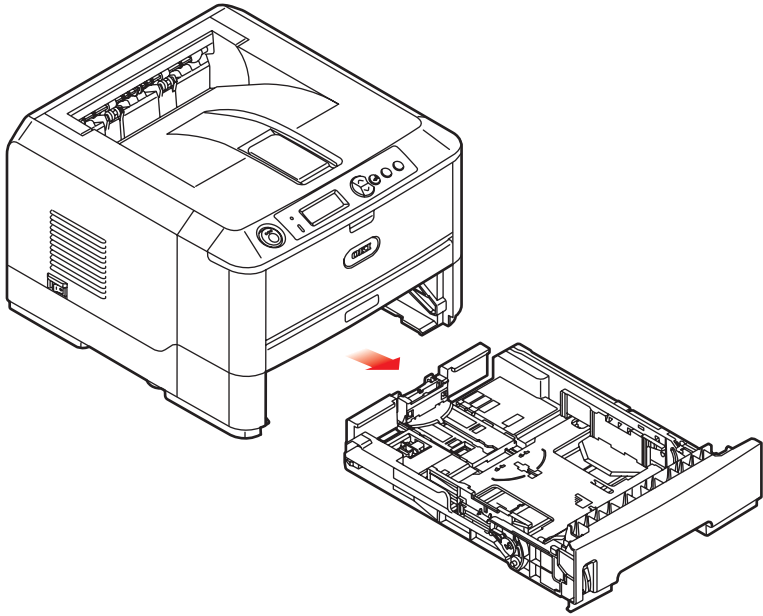

2. Fan the paper to be loaded at the edges (1) and in the middle (2) to ensure that all sheets are properly separated, then tap the edges of the stack on a flat surface to make it flush again (3).

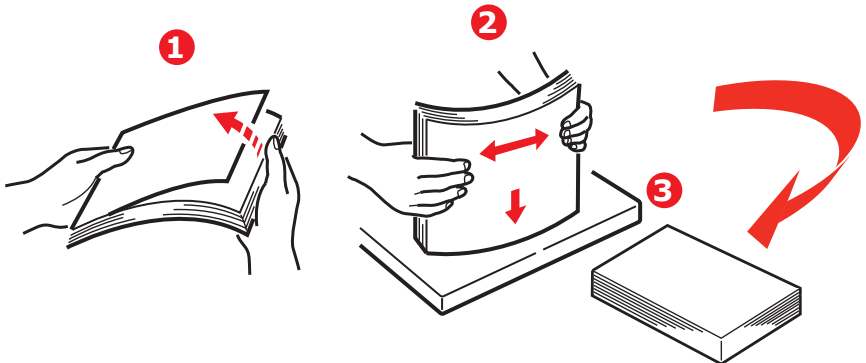

3. Load paper (letter headed paper face down and top edge towards the front of the printer), as shown.

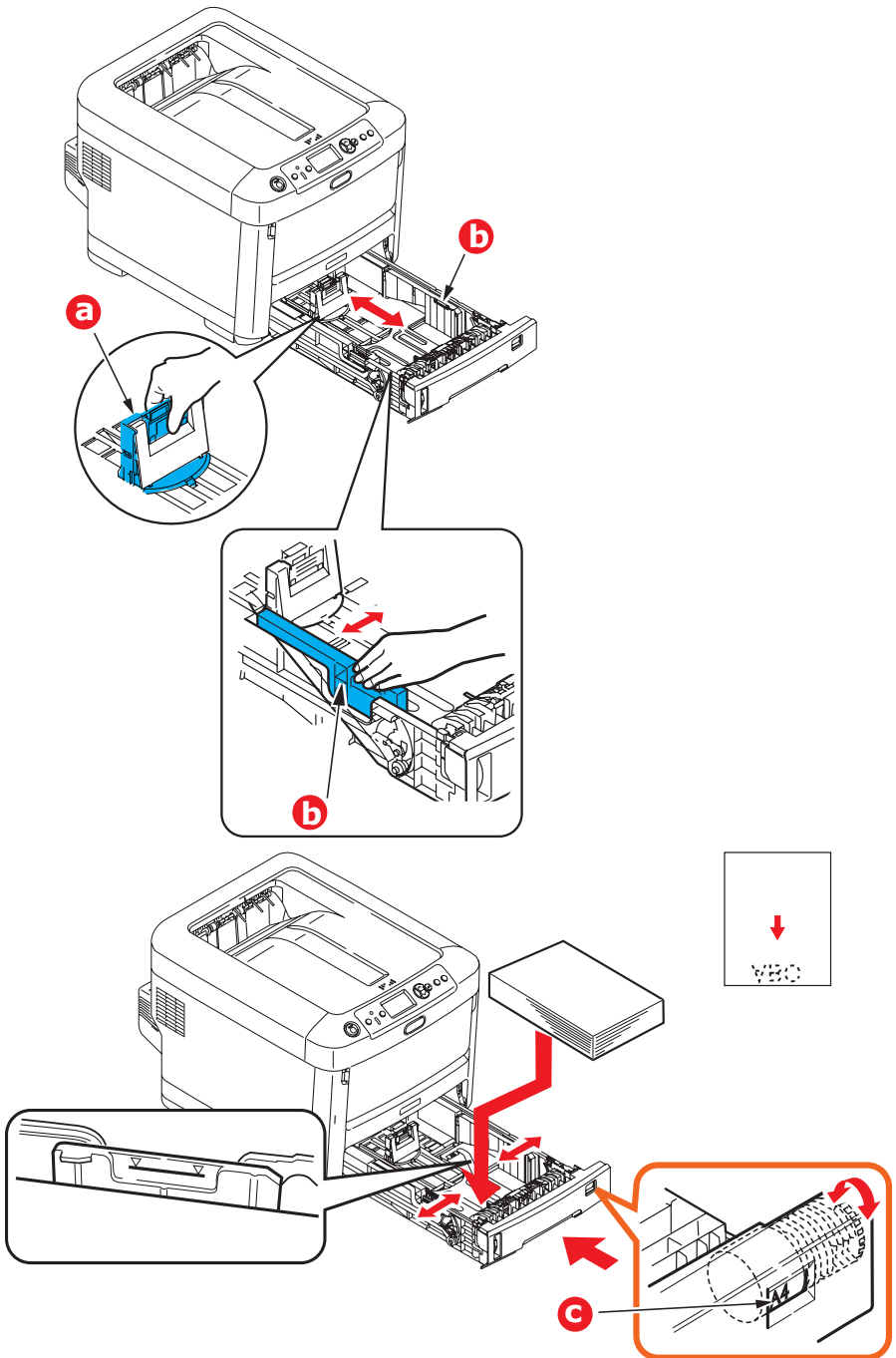

4. Adjust the rear stopper (a) and paper guides (b) to the size of paper being used.

To prevent paper jams:

- Do not leave space between the paper and the guides and rear stopper.
- Do not overfill the paper tray. Capacity depends on the type of paper stock.
- Do not load damaged paper.
- Do not load paper of different sizes or types at the same time.
- Do not pull the paper tray out during printing (except as described below for the 2nd tray).

### CAUTION!

**IMPORTANT: Set paper size dial (c) to the size of paper being used (A4 in the above example).**

- Close the paper tray gently.
- If you have two trays and you are printing from the 1st (upper) tray, you can pull out the 2nd (lower) tray during printing to reload it. However, if you are printing from the 2nd (lower) tray, do not pull out the 1st (upper) tray. This will cause a paper jam.
- For face down printing, make sure the face up (rear) stacker (a) is closed (the paper exits from the top of the printer). Stacking capacity is approximately 350 sheets of 20-lb. US Bond (75 g/m<sup>2</sup>) paper.
- For face up printing, make sure the face up (rear) stacker (a) is open and the paper support (b) is extended. Paper is stacked in reverse order and tray capacity is approximately 100 sheets of 20-lb. US Bond (75 g/m<sup>2</sup>) paper.



- Always use the face up (rear) stacker for heavy paper (card stock etc.).

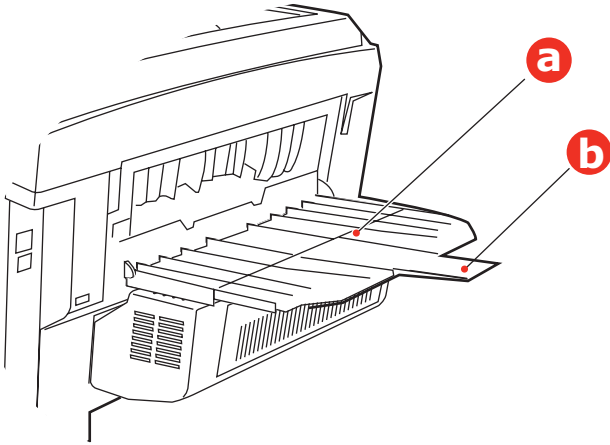

## CAUTION!

**Do not open or close the rear paper exit while printing as it may result in a paper jam.**

# Multi-Purpose Tray

---

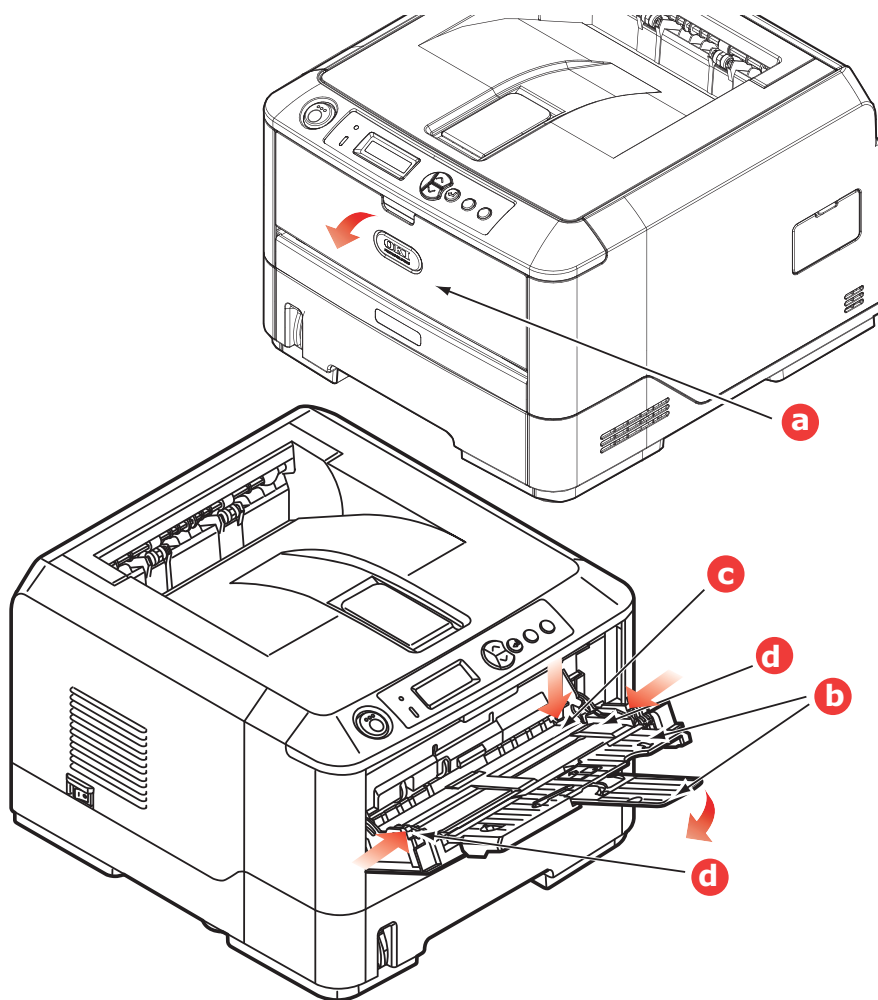

1. Open the multi purpose tray (a).
2. Fold out the paper supports (b).

3. Press gently down on the paper platform (c) to ensure it is latched down.

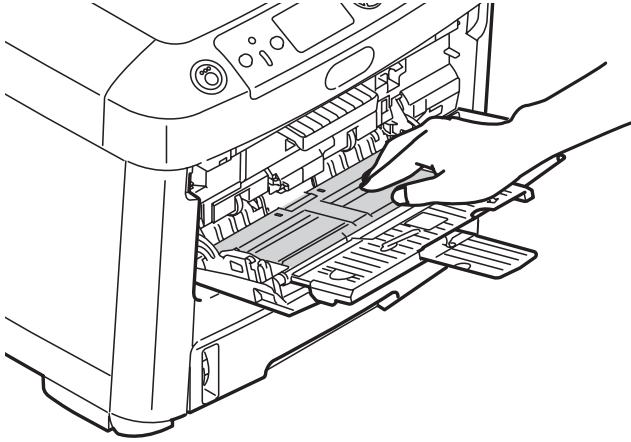

4. Load the paper and adjust the paper guides (d) to the size of paper being used.
  - For single-sided printing on letterhead paper load the paper into the multi purpose tray with pre-printed side up and top edge into the printer.
  - For two-sided (duplex) printing on letterhead paper load the paper with pre-printed side down and top edge away from the printer. (Optional duplex unit must be installed for this function.)
  - Envelopes should be loaded face up with top edge to the left and short edge into the printer. Do not select duplex printing on envelopes.
  - Do not exceed the paper capacity of about 50 sheets or 10 envelopes. Maximum stacking depth is 10mm.

5. Press the tray latch button inwards to release the paper platform, so that the paper is lifted and gripped in place.

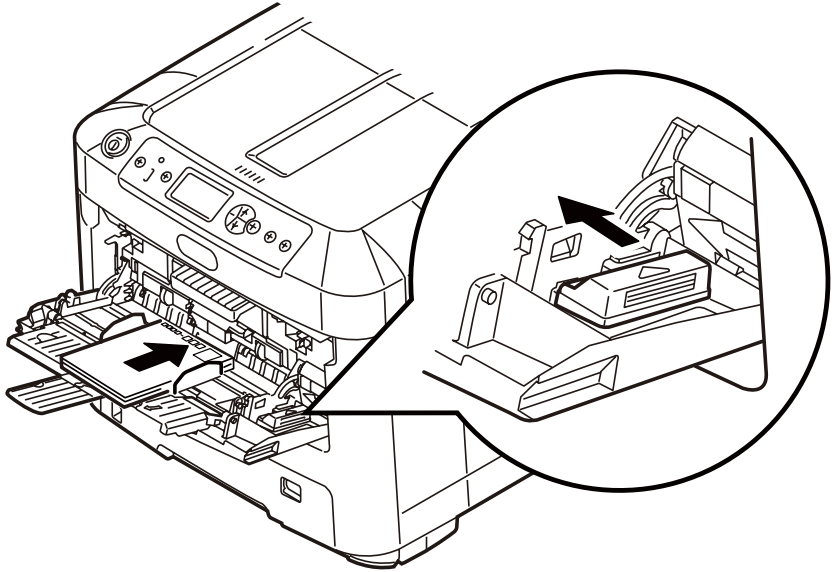

Set the correct paper size for the multi purpose tray in the Media Menu (see ["Menu functions"](#) on page 21).

# Menu functions

This section lists the menus accessed via the controls on the printer's operator panel and displayed in the LCD window.

## Operator Panel: \_\_\_\_\_

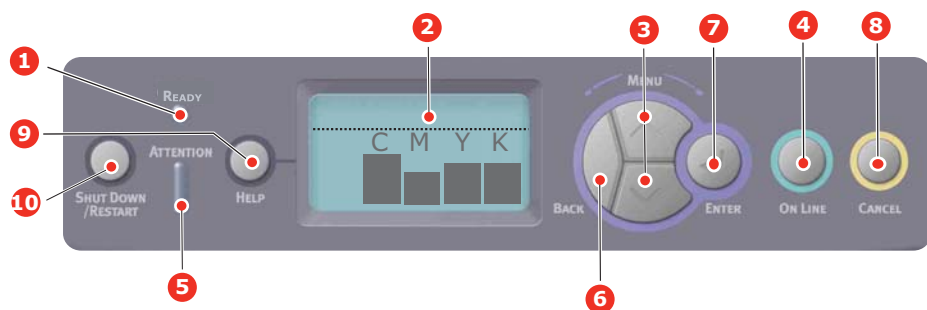

<b>1. Ready LED</b>	<b>ON:</b> Ready to receive data. <b>BLINKING:</b> Processing data. <b>OFF:</b> Offline.	<b>2. Display</b>	Displays the printer status and any error messages.
<b>3. Menu Scroll Buttons</b>	Enters the <b>Menu</b> mode. In Menu mode, forwards or reverses the menu item displayed.  Press for 2 secs. or longer to fast forward or reverse.	<b>4. On Line Button</b>	Switches between <b>ONLINE</b> and <b>OFFLINE</b> .  Exits the menu and goes <b>ONLINE</b> when pressed in the Menu mode.  Scrolls the <b>HELP</b> screen.  Forces printing on the paper currently loaded when pressed with "WRONG PAPER" or "WRONG PAPER SIZE" displayed.

<p><b>5. Attention LED</b></p>	<p><b>ON:</b> A warning occurs. Printing may be possible (e.g low toner).  <b>BLINKING:</b> An error occurs. Printing not possible (e.g. toner empty).  <b>OFF:</b> Normal condition.</p>	<p><b>6. Back Button</b></p>	<p>Returns to the previous higher level menu item.</p>
<p><b>7. Enter Button</b></p>	<p>In the <b>ONLINE</b> or <b>OFFLINE</b> mode: enters the Menu mode.  In the <b>Menu</b> mode: determines the setting selected.</p>	<p><b>8. Cancel Button</b></p>	<p>Deletes the data being printed or received when pressed for two seconds or longer.  Deletes the data when pressed for two seconds or longer with WRONG PAPER SIZE, RUN OUT OF PAPER, TRAY 1 IS OPEN, or TRAY 1 IS NOT FOUND is displayed.  Exits the menu and goes ONLINE when pressed in the Menu mode.</p>
<p><b>9. Help Button</b></p>	<p>Provides advice when an error such as incorrect paper size occurs</p>	<p><b>10. Shut Down/ Restart Button</b></p>	<p>Carries out the correct shutdown/ restart procedure to prevent possible machine damage</p>

## How to Change the Settings: User\_\_\_\_\_

It should be noted that many of these settings can be, and often are, overridden by settings in the Windows printer drivers. However, several of the driver settings can be left at "Printer Setting", which will then default to the settings entered in these printer menus.

Where applicable, factory default settings are shown in bold type in the following tables.

In the normal operating condition, known as "standby," the printer's LCD window will show "Ready to Print". In this condition, to enter the menu system, press the up and down Menu buttons on the operator panel to move up and down through the list of menus until the menu you wish to view is displayed. Then proceed as follows:

1. Press **Enter** to enter the menu.
2. Use the **up and down** MENU buttons on the control panel to scroll through the menus. When the item you want to change is displayed, press **Enter** to view the sub-menus for that item.
3. Use the **up and down** MENU buttons to move up and down through the sub-menu items. When the item you want to change is displayed press Enter to display the setting.
4. Use the **up and down** MENU buttons to move up and down through the available settings for the sub-menu item. When the item you want to change is displayed press **Enter** to display the setting. An asterisk (\*) will appear next to the setting, indicating that this setting is currently in effect.
5. Do one of the following:
  - Press **Back** again to move up to the list of menus;  
or...
  - Press **On Line** or **Cancel** to exit from the menu system and return to standby.

# How to Change the Settings: Administrator

---

You can set whether to **ENABLE** or **DISABLE** each category in the user menu.

Disabled categories are not displayed in the User's menu. Only a system administrator can change these settings.

1. Turn **OFF** the printer. Turn **ON** the printer while pressing the Enter button.  
When **Boot Menu** appears, take your finger off the button.
2. Press the **Enter** button.
3. When **Enter Password** appears, press the **up or down MENU** button, each time followed by Enter, then **Enter** several times to input the 1st line of the your password, and then press the **Enter** button.

***Enter your 4 to 9 digit password.***

(The default password is aaaaaa).

4. Press the **Enter** button.
5. Press the **up and down MENU** button until the "category" you want to change is displayed.
6. When it is, press the **Enter** button.
7. Press the MENU **up** button or MENU **down** button until the "item" you want to change is displayed.
8. When it is displayed, press the **Enter** button.
9. Using the MENU **up** button or MENU **down** button, identify the parameter as required.
10. Press the **Enter** button to enter an asterisk (\*) on the right side of the setting selected.
11. Press the **On Line** button to switch to online. The machine will automatically re-boot.



# Configuration Menu

ITEM	ACTION	EXPLANATION
Page Count	Tray1 Tray 2* Tray 3* MPT Tray *Note: Only available when optional trays are present	Select an item to display the total number of pages printed from the relevant tray.
Supplies Life	Cyan Drum Magenta Drum Yellow Drum Black Drum Belt Fuser Cyan Toner Magenta Toner Yellow Toner Black Toner	Select item to display the percentage of a consumable remaining.
Network	Printer Name Short Printer Name IP Address Subnet Gateway MAC Address Network FW Version Web Remote version	Displays the full printer name. Displays an abbreviated version. Displays the IP Address Subnet of the network. Displays the Gateway of the network. Displays the Mac Address of the printer. Displays the Network firmware revision. Displays the Web remote version.
System	Serial Number Asset Number Lot Number CU Version PU Version Total Memory Flash Memory HDD	Displays information for these items.

# Print Information Menu

This menu provides a quick method of listing various items stored within the printer.

ITEM	ACTION	EXPLANATION
Configuration	Execute	Select execute to print out a configuration report.
Network	Execute	Scroll down to this parameter and select execute to print out Network information.
Demo Page Demo 1	Execute	Scroll down to this parameter and select execute to print out a demonstration page.
File List	Execute	Scroll down to this parameter and select execute to print out a list of job files. (displayed only if FileSystem is installed).
PS font List	Execute	Scroll down to this parameter and select execute to print out a Postscript emulation typeface list.
PCL font List	Execute	Scroll down to this parameter and select execute to print out a PCL font list.
IBM PPR Font List	Execute	Scroll down to this parameter and select execute to print out an IBM PPR font list.
EPSN FX Font List	Execute	Scroll down to this parameter and select execute to print out an Epson FX emulation font list.
Usage Report	Execute	Scroll down to this parameter and select execute to print out a list of color and mono pages printed.
Error Log	Execute	Scroll down to this parameter and select execute to print out the error log.
Color Profile List	Execute	Scroll down to this parameter and select execute to print out a list of color profiles.

# Print Secure Job Menu

**Note:**

Only present if an optional Hard disk Drive (HDD) is fitted.

ITEM	ACTION	EXPLANATION
Encrypted Job	Not Found Print Delete	<p>Used for printing an encrypted authentication print job (Encrypted Job) stored in HDD.</p> <p>After inputting a password, "Searching Job" is displayed until a job appropriate for the password is found.</p> <p>(Searching time increases in proportion to the number of jobs stored in HDD, and the printer may take up to 20 sec.)</p> <p>The search can be cancelled by holding down the Cancel button.</p> <p>Not Found will be displayed where a file, which could be printed is not available.</p> <p>The following message will appear if a printable file is available.</p> <p><b>Encrypted Job</b></p> <p><b>Print</b></p> <p><b>Delete</b></p> <p>A set of all jobs will be printed if Print is selected and the Enter button is pressed.</p> <p>The following message will appear if Delete is selected:</p> <p><b>Are You Sure?</b></p> <p><b>Yes</b></p> <p><b>No</b></p> <p>The display will return to the source menu if No is selected.</p> <p>All jobs will be deleted if Yes is selected.</p> <p>Print jobs with encrypted authentication stored in HDD are deleted by a delete method specified by the driver after printing or a delete instruction from the menu.</p>

ITEM	ACTION	EXPLANATION
Stored Job	Not Found Print Delete	<p>Used to print out a stored job in a HDD.</p> <p><b>Not Found</b> will be displayed where a file, which could be printed is not available.</p> <p>The following message will appear if a printable file is available.</p> <p><b>Stored Job</b></p> <p><b>Print</b></p> <p><b>Delete</b></p> <p>When <b>Print</b> is selected, <b>Set Collating Amount</b> is displayed and the number of pages to print can be specified.</p> <p>Specify the number of pages to print and press the <b>Enter</b> button.</p> <p>The following message will appear if <b>Delete</b> is selected:</p> <p><b>Are You Sure?</b></p> <p><b>Yes</b></p> <p><b>No</b></p> <p>If <b>No</b> is selected, the display will return to the previous menu.</p> <p>If <b>Yes</b> is selected, all jobs will be deleted.</p>

# Menus Menu

ITEM	ACTION	EXPLANATION
Tray Configuration ?	Paper feed Default: <b>Tray 1</b>	Select tray (default condition indicated by *) Select by scroll and <b>Enter</b> button.
	Auto Tray Switch Default: <b>On</b>	Switches Auto ON/OFF (default condition indicated by *). Select by scroll and <b>Enter</b> button.
	Tray Sequence Default: <b>Down</b>	Selects Tray sequence <b>Down/Up/ Paper feed Tray</b> (default condition indicated by *). Select by scroll and <b>Enter</b> button.
	Unit of Measurement Default: <b>millimeter</b>	Selects UOM Inches or millimeter (default condition indicated by *). Select by scroll and <b>Enter</b> button.
	Tray1 Configuration Default: Paper size: <b>Cassette/ Custom</b> Media Type: <b>Plain/ Letterhead/ Bond/recycled/ Card stock/ Rough/Glossy/</b> *User type 1-5 Media Weight: <b>Light/ Medium Light/Medium/ Heavy/Ultra Heavy1</b>	Configure <b>Paper Size/Media Type/ Media Weight</b> . Defines default condition (indicated by *) Select by scroll and <b>Enter</b> button. *User type 1 to 5 are displayed only if registered in the host PC.

ITEM	ACTION	EXPLANATION
Tray Configuration (cont.)	<p>MPT Tray Configuration</p> <p><b>Paper size:</b></p> <ul style="list-style-type: none"> <li>• A4/A5/A6/B5</li> <li>• Legal14/Legal 13.5/Legal13</li> <li>• Letter</li> <li>• Executive</li> <li>• Custom</li> <li>• Com-9 Envelope</li> <li>• Com-10 Envelope</li> <li>• Monarch Envelope</li> <li>• DL Envelope</li> <li>• C5</li> </ul> <p><b>Media Type:</b></p> <ul style="list-style-type: none"> <li>• Plain</li> <li>• Letterhea</li> <li>• Transparency</li> <li>• Labels</li> <li>• Bond</li> <li>• Recycled</li> <li>• Card Stock</li> <li>• Rough</li> <li>• Glossy</li> <li>• Usertype 1-5</li> </ul> <p><b>Media Weight:</b></p> <ul style="list-style-type: none"> <li>• Light</li> <li>• Medium Ligh</li> <li>• Medium</li> <li>• Heav</li> <li>• Ultra Heavy 1</li> <li>• Ultra Heavy 2*</li> </ul> <p><b>Tray usage:**</b></p> <ul style="list-style-type: none"> <li>• Do Not Use</li> <li>• When Mismatching</li> </ul>	<p>Configure <b>Paper Size/Media Type/Media Weight/Tray Usage.</b></p> <p>Defines default condition (indicated by *) Select by scroll and <b>Enter</b> button.</p> <p>User type 1 to 5 are displayed only if registered in the host PC.</p> <p>* Ultra Heavy2 = 189-220/gm<sup>2</sup></p> <p>** Sets MPTray usage.</p> <p><b>When Mismatching:</b> if paper mismatch occurs, paper is requested from the MPTray instead of the specified tray.</p> <p><b>Do Not Use:</b> sets MPTray unavailable both in Auto Tray Select and Auto Tray Switch.</p>
	<p>Tray 2 Config*</p> <p>Tray 3 Config*</p>	<p>Same as Tray 1 Config.</p> <p>*Note: only present if option installed</p>

ITEM	ACTION	EXPLANATION
System Adjust	Power Save Time Default: <b>5</b>	Select from <b>5/10/15/30/60 Minutes</b> . Select by scroll and <b>Enter</b> button.
	Clearable Warning Default: <b>ONLINE</b>	Select from: <b>ONLINE/Job</b> . Select by scroll and <b>Enter</b> button. PS job only.
	Auto Continue Default: <b>Off</b>	Select from <b>On/Off</b> . Select by scroll and <b>Enter</b> button.
	Manual Timeout Default: <b>60</b>	Select fro <b>Off/30 seconds/60 seconds</b> . Select by scroll and <b>Enter</b> button.
	Wait Timeout Default: <b>40</b>	Select from <b>Off/5/10/20/30/40/50/60/90/120/150/180/210/240/270/300 seconds</b> . Select by scroll and <b>Enter</b> button.
	Low Toner Default: <b>Continue</b>	Select action to take when toner sensor indicates low toner. Select from <b>Continue/Stop</b> (default condition indicated by *). Select by scroll and <b>Enter</b> button.
	Jam Rcovery Default: <b>On</b>	Select from <b>On/Off</b> . Select by scroll and <b>Enter</b> button.
	Error Report Default: <b>Off</b>	Select from <b>On/Off</b> (default condition indicated by *). Select by scroll and <b>Enter</b> button.
	Print Position Adjust Default: <b>0.00</b>	Select from <b>X Adjust/Y Adjust/Duplex X Adjust/Duplex Y adjust</b> (default condition indicated by *). Select by scroll and <b>Enter</b> button. Define measurement.

ITEM	ACTION	EXPLANATION
System Adjust (cont.)	Paper Black Settings -2/-1/0/+1/+2 Default: <b>0</b>	Used for fine adjustment of the black print on paper.
	Paper color Settings-2/-1/0/+1/+2 Default: <b>0</b>	Used for fine adjustment of the color print on paper.
	Trans. Black Settings -2/-1/0/+1/+2 Default: <b>0</b>	Used for fine adjustment of the black print on transparencies.
	Trans. color Settings -2/-1/0/+1/+2 Default: <b>0</b>	Used for fine adjustment of the color print on transparencies.
	SMR Setting +3/+2/+1/- /-2/-3 Default: <b>0</b>	To correct variations in print results caused by temperature/humidity conditions and difference in print density/frequency. Change the setting when print quality is uneven.
	BG Setting +3/+2/+1/-1/-2/-3 Default: <b>0</b>	To correct variations in print results caused by temperature/humidity conditions and difference in print density/frequency. Change the setting when background is dark.
	Drum Cleaning Default: <b>Off</b>	Sets whether to rotate the drum in idle prior to printing in order to reduce horizontal white lines. This will shorten the ID life by as much as this rotation. Select by scroll and <b>Enter</b> button.
	Hex Dump <b>Execute</b>	Prints out data received from the host PC in the hexadecimal Dump. Turning off the power supply switch restores Normal Mode.



# Shutdown menu

This menu only appears if the hard disk drive is installed.

This item should always be selected before switching the printer off, to ensure that no hard disk data is lost.

ITEM	SETTINGS	EXPLANATION
Shutdown Start	Execute	Performs controlled shutdown of the printer, ensuring that all files on the internal hard disk are closed before power is turned off. Only power the printer off when the display indicates that shutdown is complete.

# Admin Setup

ITEM		SETTINGS	EXPLANATION
Enter Password		xxxxxxxxxxxx	Enter a password to gain entry to the Admin Setup menu. Password should be from 6 to 12 digits of alpha/numeric characters (or mix) The default value is "aaaaaa"
Network Setup	TCP/IP	<b>Enable</b> Disable	Sets TCP/IP Protocol. Enable: TCP/IP Protocol is available. Disable: TCP/IP Protocol is not available.
	IP Version	<b>IP v4</b> IP v4+v6	Set up the IP version. Operates with IPv4 for IPv4 (not valid with IPv6). Operates with both IPv4 and IPv6
	NetBEUI	<b>Enable</b> Disable	Sets Enable/Disable of NETBEUI Protocol.

ITEM		SETTINGS	EXPLANATION
Network Setup (cont.)	NetWare	<b>Enable</b> Disable	Sets Enable/Disable of NetWare Protocol.
	EtherTalk	<b>Enable</b> Disable	Sets Enable/Disable of EtherTalk Protocol.
	Frame Type	<b>Auto</b> 802.2 802.3 Ethernet II SNAP	Sets the frame type. Netware should be enabled.
	TypeIP Address Set	<b>Auto</b> Manual	Sets the IP Address setting method. TCP/IP should be enabled.
	IP Address	xxx.xxx.xxx.xx x	Sets the IP Address. TCP/IP should be enabled.
	Subnet Mask	xxx.xxx.xxx.xx x	Sets the Subnet Mask. TCP/IP should be enabled.
	Gateway Address	xxx.xxx.xxx.xx x	Sets the Gateway (default router) address. 0.0.0.0 means that there is no router. TCP/IP should be enabled.
	Web	<b>Enable</b> Disable	Sets Enable/Disable of Web. Enable: Web/IPP is available. Disable: Web/IPP is not available. TCP/IP should be enabled.
	Telnet	Enable <b>Disable</b>	Sets Enable/Disable of Telnet. Enable: Telnet is available. Disable: Telnet is not available. TCP/IP should be enabled.

ITEM		SETTINGS	EXPLANATION
Network Setup (cont.)	FTP	<b>Enable</b> Disable	Sets Enable/Disable of FTP. Enable: FTP is available. Disable: FTP is not available. TCP/IP should be enabled.
	SNMP	<b>Enable</b> Disable	Sets Enable/Disable of SNMP. Enable: SNMP is available. Disable: SNMP is not available. TCP/IP or NetWare should be enabled.
	Network Scale	<b>Normal</b> Small	When <b>Normal</b> is selected, the network can work effectively even when it is connected to a HUB that has a spanning tree feature. However, printer start up time gets longer when computers are connected with two or three small LANs. When <b>Small</b> is selected, computers can cover from two or three small LANs to a large LAN, but may not work effectively when the network is connected to a HUB with a spanning tree feature.
	Hub Link Setting	<b>Auto Negotiate</b> 100Base-TX Full 100Base-TX Half 10Base-T Full 10Base-T Half	Sets a method to link to a HUB. When <b>Auto</b> is set, a connection method to a HUB is selected automatically.
	Factory Defaults?	Execute	Specifies whether to initialize the network factory default settings for the Network.

ITEM		SETTINGS	EXPLANATION
Print Setup	Personality	<b>Auto</b> PostScript PCL IBM PPR EPSON FX	Selects a printer language.
	Copies	<b>1</b> - 999	Selects the default number of copies.
	Duplex	<b>On/Off</b>	Specifies Duplex print (option) if a Duplex unit is installed and enabled
	Binding	<b>Long Edge</b> Short Edge	Specifies Binding in duplex printing (if a Duplex unit is installed and enabled)
	Media Check	<b>Enable</b> Disable	Sets whether the printer checks the matching of printed data size and that of the tray. Only standard sizes are checked.
	Resolution	600dpi <b>600x1200dpi</b> 600dpi multi-level.	Sets default resolution.

ITEM		SETTINGS	EXPLANATION
Print Setup (cont.)	Toner Save Mode	<b>On/Off</b>	<p>This function works effectively only if the data input is color RGB data. This setting is valid in PS and PCL, but does not take effect in the following cases.</p> <p>(1) PS: If Color Matching is set OFF.</p> <p>(2) PS: If any setting other than ASIC Color Matching is set.</p> <p>(3) PS: CMYK data when Ink Simulation Mode is used (valid in any other cases except Case (1) and Case (2) above as long as data is RGB).</p> <p>(4) PCL binary data (Color/ Monochrome).</p>
	Mono-Print Speed	<b>Auto</b> Color Speed Normal Speed High Quality	<p>Sets the monochrome print speed. Prints at the most appropriate speed for page process if <b>Auto</b> is set.</p> <p>Prints always at the color print speed if <b>Color</b> is set.</p> <p>Prints always at the monochrome print speed if <b>Normal</b> is set.</p> <p>Prints always at 26ppm of the gradation print speed for both color and monochrome print if <b>High Quality</b> is set.</p>
	Default Orientation	<b>Portrait</b> Landscape	<p>Specifies print orientation.</p> <p>Not valid for PS (valid only for PCL/ IBMPPR/EPSONFX/ HP-GL2).</p>

ITEM		SETTINGS	EXPLANATION
Print Setup (cont.)	Form Length	5 lines ~ <b>60 lines</b> ~ 128 lines	Sets the number of lines that can be printed on a page Not valid for PS (valid only for PCL/HP-GL2). Default values listed to the left are for Letter/A4. In practice, however, they change according to the size of paper loaded in the tray.
	Edit Size	<b>Cassette Size/Letter/</b> Executive/ Legal14/ Legal13.5/ Legal13/A4/ A5/A6/B5/ Custom/C5/ Com-10 Envelope/ Monarch Envelope/DL Envelope/C5/ Com-9 Envelope	Sets the size of an area to draw when the host PC does not specify the size via the paper edit size designating command (Not valid for PS - only for PCL).
	Trapping	<b>Off</b> Narrow Wide	Trapping, or spreading and choking, is a prepress technique consisting of creating small overlaps between abutting colors in order to mask registration issues in the graphical production.
	Trapping X Width	<b>0</b> pixels ~ 4 pixels	Sets the horizontal dimension of the trapping area.
	Trapping Y Width	<b>0</b> pixels ~ 4 pixels	Sets the vertical dimension of the trapping area.

ITEM		SETTINGS	EXPLANATION
Print Setup (cont.) PS Setup	X Dimension	64 mm ~ <b>210 mm</b> ~ 216 mm	Specifies paper width of Custom paper as a default value. Sets a paper size at right angles to the paper run direction.
	Y Dimension	127 mm ~ <b>297 mm</b> ~ 1220 mm	Specifies paper length of Custom paper as a default value. Sets a paper size in the same direction as the paper run direction.
	Network Protocol	<b>ASCII/RAW</b>	Specifies PS communication protocol mode of data from NIC port.  (In RAW mode, Ctrl-T is invalid). PS models only.
	Parallel Protocol	<b>ASCII/RAW</b>	Specifies PS communication protocol mode of data from Centronics port.  (In RAW mode, Ctrl-T is invalid). PS models only.
	USB Protocol	<b>ASCII/RAW</b>	Specifies PS communication protocol mode of data from USB port.  (In RAW mode, Ctrl-T is invalid). PS models only.
PCL Setup	Font Source	Resident	Specifies the location of PCL default font.
	Font Number	<b>10 ~ I90</b>	Sets the PCL font number. The valid range of this variable changes depending on the FONT SOURCE setting at the time. If the default font is set for FONT SOURCE, the number starts at 0. If it is not, the number starts at 1. The maximum value is equal to the number of fonts installed in FONT SOURCE.

ITEM		SETTINGS	EXPLANATION
PCL Setup (cont.)	Font Pitch	99.9 CPI ~ <b>10.00 CPI</b> ~ 0.44 CPI	Width of the PCL default font in characters per inch (CPI). Default font is fixed-pitch, scalable font.  The value of pitch is displayed down to the second decimal place.  Displayed only when the font selected in Font No. is a fixed-spacing, scalable font.
	Symbol Set	PC-8	Sets the symbol set of PCL (see machine operator panel for complete list).
	A4 Print Width	<b>78 column</b> 80 column	Sets the number of characters for A4 paper. Auto LF. This is for 10-CPI characters when Auto CR/LF Mode is set to OFF.  This menu is enabled only when A4 paper is selected in the menu that sets the print width of A4 paper in portrait orientation.  Usually, such A4 paper print width is set slightly narrower than 8 inches (about 7.93 inches).  This setting cannot print 80 10-cpi characters (only prints up to 78 10-cpi characters). 80 characters set at A4 Print Width widen the right and left margins.  A PCL command selects or selects/deselects Auto CR/LF mode.



ITEM		SETTINGS	EXPLANATION
PCL Setup (cont.)	White Page skip	<b>On/Off</b>	Sets whether to eject a page without any data to print (blank page) upon reception of FF command (OCH) in PCL Mode. OFF: Ejecting.
	CR Function	<b>CR/CR+LF</b>	Sets action when CR code is received in PCL. CR: Carriage Return CR+LF: Carriage Return and Line Feed
	LF Function	<b>LF/LF+CR</b>	Sets action when LF code is received in PCL. LF: Line Feed LF+CR: Line Feed and Carriage Return
	Print Margin	<b>Normal</b> 1/5 inch 1/6 inch	Sets a non-printable area of paper. The width of the area along the right and left sides of paper (left and right sides depend on paper orientation). NORMAL: PCL emulation compatible, approximately 1/4~1/4.3INCH (depending on paper) is outside the printable area.
	True Black	<b>On/Off</b>	Sets whether to use Composite Black (cmyk mixed) or Pure Black (K only) for the black (100%) in image data. OFF: Mode using Composite Black ON: Mode using Pure Black (PCL only)

ITEM		SETTINGS	EXPLANATION
PCL Setup (cont.) )	Pen Width Adjust	<b>On/Off</b>	<p>When minimum width is specified in PCL, sometimes a 1-dot line, looks broken.</p> <p>With PEN WIDTH Adjust set to ON, when the minimum width is specified, the line width will be emphasized so as to look wider than a 1-dot line.</p> <p>With PEN WIDTH Adjust set to OFF, the line will appear as before.</p>
	Tray 2 ID#	1 ~ <b>5</b> ~ 59	<p>Sets the # to specify Tray 2 for the paper feed destination command (ESC&amp;I#H) in PCL5e emulation.</p> <p>(Displayed only if Tray 2 is installed).</p>
	Tray 3 ID#	1 ~ <b>20</b> ~ 59	<p>Sets the # to specify Tray 3 for the paper feed destination command (ESC&amp;I#H) in PCL5e emulation.</p> <p>(Displayed only if Tray 3 is installed).</p>
	MPTray ID#	1 ~ <b>4</b> ~ 59	<p>Sets the # to specify the MP tray for the paper feed destination command (ESC&amp;I#H) in PCL5e emulation.</p>
IBM PPR Setup	Character Pitch	<b>10 CPI</b> 12 CPI 17 CPI 20 CPI Proportional	<p>Specifies character pitch in IBM PPR emulation.</p>
	Font Condense	<b>12CPI to 20CPI</b> 12CPI to 12CPI	<p>Specifies 12CPI pitch for Condense Mode.</p>
	Character Set	<b>SET-2</b> SET-1	<p>Sets a character set.</p>

ITEM		SETTINGS	EXPLANATION
IBM PPR Setup (cont.)	Symbo Set	<b>IBM 437</b>	Sets the Symbol Set for IBM PPR (see machine operator panel for complete list).
	Letter O Style	Enable/ <b>Disable</b>	Specifies the style that replaces ø (9B) and ¥ (9D) with ø (ou) and Ø (zero).
	Zero Character	<b>Normal/</b> Slashed	Specifies the style of 0(zero). SLASHED: SLASH ZERO
	Line Pitch	<b>6/8</b> LPI	Sets line space.
	White Page Skip	On/ <b>Off</b>	Sets whether to eject a blank sheet. Available only when simplex is set.
	CR Function	<b>CR/CR+LF</b>	Sets action when CR code is received.
	LF Function	<b>LF/LF+CR</b>	Sets action when LF code is received.
	Line Length	<b>80/136</b> Column	Specifies the number of characters per line.
	Form Length	11/ <b>11.7/12</b> inch	Specifies the length of paper.
	TOF Position	<b>0.0/0.1/~1.0</b> inch	Sets the position from the top edge of paper.
	Left Margin	<b>0.0/0.1/~1.0</b> inch	Sets the amount to shift the horizontal print start position to the right.
	Fit to Letter	Enable/ <b>Disable</b>	Sets the printing mode that can fit print data, equivalent to 11 inches (66 lines), in the LETTER-size printable area.
	Text Height	<b>Same/</b> Diff	Sets height of a character. SAME: Regardless of CPI, same height DIFF: According to CPI, character heights vary.

ITEM		SETTINGS	EXPLANATION
EPSON FX Setup	Character Pitch	<b>10 CPI/12 CPI/17 CPI</b> 20 CPI/ Proportional	Specifies character pitch in Epson FX emulation.
	Character Set	<b>SET-2</b> SET-1	Sets a character set.
	Symbol Set	<b>IBM 437</b>	Sets the Symbol Set for Epson FX Emulation. (see machine operator panel for complete list).
	Letter O Style	Enable/ <b>Disable</b>	Specifies the style that replaces ø (9B) and ¥ (9D) with ø (ou) and Ø (zero).
	Zero Character	<b>Normal/</b> Slashed	Specifies the style of 0(zero). SLASHED: SLASH ZERO
	Line Pitch	<b>6/8 LPI</b>	Sets line space.
	White Page Skip	On/ <b>Off</b>	Sets whether to eject a blank sheet. Available only when simplex is set.
	CR Function	<b>CR/CR+LF</b>	Sets action when CR code is received.
	Line Length	<b>80/136</b> Column	Specifies the number of characters per line.
	Form Length	11/ <b>11.7/12</b> inch	Specifies the length of paper.
	TOF Position	<b>0.0/0.1/~1.0</b> inch	Sets the position from the top edge of paper.
	Left Margin	<b>0.0/0.1/~1.0</b> inch	Sets the amount to shift the horizontal print start position to the right.
	Fit to Letter	Enable/ <b>Disable</b>	Sets the printing mode that can fit print data, equivalent to 11 inches (66 lines), in the LETTER-size printable area.

ITEM		SETTINGS	EXPLANATION
EPSON FX Setup (cont.)	Text Height	<b>Same/Diff</b>	Sets height of a character. SAME: Regardless of CPI, same height DIFF: According to CPI, character heights vary.
Color Setup	Ink Simulation	<b>Off</b> SWOP Euroscale Japan	The machine has its own process simulation engine which simulates standard colors in the printer. This function is available only with PS language jobs.
	UCR	<b>Low</b> Medium High	Selects limitation to the toner layer thickness. If paper curl occurs in dark printing, selecting MEDIUM or LIGHT sometimes helps reduce this curl. UCR = Under Color Removal.
	CMY 100% Density	Enable/ <b>Disable</b>	Enable/Disable 100% output against the CMY100% TRC compensation. Ordinarily, the TRC compensation function holds control for the appropriate print density; thus 100% output is not always possible. Selecting ENABLE will enable 100% output in any individual color. The actual print, including the TRC compensation function is limited to an appropriate area. This function is for special purposes such as specification in CMYK color reduction in PS.
	CMYK Conversion	<b>On/Off</b>	Setting to "OFF" will simplify the conversion process of CMYK data, which will reduce the processing time. This setting is ignored when Ink Simulation function is used. PS only

ITEM		SETTINGS	EXPLANATION
Memory Setup	Receive Buffer Size	<b>Auto</b> 0.5 megabyte 1 megabyte 2 megabyte 4 megabyte 8 megabyte 16 megabyte	Sets the size of receive buffer
	Resource Save	<b>Auto</b> <b>Off</b> 0.5 megabyte 1 megabyte 2 megabyte 4 megabyte 8 megabyte 16 megabyte	Sets the size of resource saving area.
HDD Setup <i>This item is displayed only if a HDD (option) is installed.</i>	Initialize	Execute	<p>Initializes the HDD to the factory default setting. Machine performs partition-division, and initializes each partition.</p> <p>When this menu is executed, the following confirmation message appears.</p> <p>Are You Sure? Yes/No</p> <p>If <b>No</b> is selected, you will return to the previous menu.</p> <p>If <b>Yes</b> is selected, the following confirmation message appears.</p> <p>Execute Now? Yes/No</p> <p>If <b>No</b> is selected, you will return to the previous menu.</p> <p>The request to execute HDD initialization is put into the memory and initialization will be executed at the next power cycle.</p> <p>If <b>Yes</b> is selected, shutdown takes place, and the HDD is initialized at power Off/On cycle.</p>

ITEM		SETTINGS	EXPLANATION
HDD Setup (cont.)	Resize Partition	PCL nn%/ Common mm%/PSII%/ <Apply>	<p>Specifies the size of partition. Specifies a size by ratio to the whole HDD in % (1% unit). nn,mm,II: 1 - 98 and nn+mm+II=100</p> <p>The sizes are displayed in the partition list and can be changed by selecting the partition size to be changed. If <b>Apply</b> is selected, the following confirmation message appears.</p> <p><b>Are You Sure? Yes/No</b></p> <p><b>No</b> = return to the previous menu.</p> <p><b>Yes = Execute Now? Yes/No</b></p> <p><b>No</b> = return to the previous menu. The request is put into the memory and the hard disk initialization and partition size change will be executed at next power cycle.</p> <p><b>Yes</b> = shutdown. Hard disk initialization and partition size change will be executed at Power Off/On cycle.</p> <p>In Non-PS machines, PS is replaced by COMMON, so the message is displayed as "PCL/COMMON/COMMON".</p>

ITEM		SETTINGS	EXPLANATION
HDD Setup (cont.)	Format Partition	PCL Common PS	<p>Formats a specified partition. When the <b>Enter</b> button is pressed, the following confirmation message appears.</p> <p><b>Are You Sure? Yes/No</b></p> <p><b>No</b> =I return to the previous menu.</p> <p><b>Yes = Execute Now? Yes/No</b></p> <p><b>No</b> i=I return to the previous menu. The request to execute partition formatting is put into the memory and formatting will be executed at next power cycle.</p> <p><b>Yes</b> =shutdown. The partition is formatted at power Off/On cycle.</p> <p>In Non-PS machines, PS is replaced by Common, so the message is displayed as "PCL/Common/Common".</p>
System Setup	Near Life LED	<b>Enable/Disable</b>	<p>Controls the settings of the <b>Attention LED</b> when near end of life warning of toner, drum, fuser, or belt occurs.</p> <p>Attention LED is lit when enabled, not lit if disabled. (Displays LCD message.)</p> <p>The temporary recovery by opening and closing of the cover in Life error is not included.</p>
	Reset Section Counter	Execute	<p>Resets the section counter of print statistics function to zero. If <b>Execute</b> is selected, exits from the menu.</p>



ITEM		SETTINGS	EXPLANATION
Change Password	New Password	xxxxxxxxxxxx xx	Sets a new password to enter Admin Setup menu From 6 to 12 alpha/numeric digits can be entered.
	Verify password	xxxxxxxxxxxx xx	Forces the User to input the new password to enter Admin Setup. From 6 to 12 alpha/numeric digits can be entered.
Settings	Reset Settings	Execute	Resets EEPROM of CU. Resets User menu to the factory default. If <b>Execute</b> is selected, exits from the menu.
	Save Settings	Execute	Saves menus currently set. With this function, the menus with which operation was last performed are saved, and overwrites with them menus that were previously saved. When the <b>Enter</b> button is pressed, the following confirmation message appears. <b>Are You Sure? Yes/No</b> <b>No</b> = the preceding menus are restored. <b>Yes</b> =, the current menu settings are saved and this menu is exited.

# Calibration

ITEM		SETTINGS	EXPLANATION
Auto Density		On/Off	Enables/disables automatic density adjustment.
Adjust Density		Execute	<p>If Execute is selected, the printer will immediately adjust density and reflect it in TRC compensation.</p> <p><b>This adjustment must be executed when the printer is idling. It can become invalid if executed in any other state.</b></p>
Adjust Registration		Execute	<p>When this menu is selected, the printer performs AutoAdjust Registration.</p> <p><b>This adjustment must be executed when the printer is idling.</b></p>
Print Tuning Pattern		Execute	<p>Prints the pattern for the user to adjust TRC. Ordinarily, this function is not needed because TRC is automatically adjusted to the recommended levels through density adjustment and TRC compensation.</p> <p>Adjustment results will be reflected as offset values (addition) to the corrections through the Adjust Density/TRC Compensation function.</p>

ITEM		SETTINGS	EXPLANATION
Cyan/ Magenta/ Yellow/Black Tuning	Highlight	-3,-2,- 1, <b>0</b> ,+1,+ 2,+3,	Adjusts HIGHLIGHT (light area) of the TRC. + = Darker - = Lighter
	Mid-Tone	-3,-2,- 1, <b>0</b> ,+1,+ 2,+3,	Adjusts MID-TONE area of the TRC. + = Darker - = Lighter
	Dark	-3,-2,- 1, <b>0</b> ,+1,+ 2,+3,	Adjusts DARK area of the TRC. + = Darker - = Lighter
Cyan/ Magenta/ Yellow/Black Darkness		-3,-2,- 1, <b>0</b> ,+1,+ 2,+3,	Adjusts the engine density. The Darkness settings for each of CMYK will be reflected as offset values (addition) to the corrections through the Adjust Density/TRC Compensation function.

# Print Statistics

ITEM	SETTINGS	EXPLANATION
Enter Password	XXXX	<p>Enters a password to enter Print Statistics menu.</p> <p>The default value is "0000".</p> <p>The password for entry to Print Statistics is different from the password for entry to Functions-Admin Setup.</p> <p>"Print Statistics" category is not shown when Print Statistics function is not supported.</p>
Section Counter	<b>Enable/Disable</b>	<p>Specifies if the section counter is displayed in Usage Report Print or not.</p> <p>Enable: Displayed</p> <p>Disable: Not displayed.</p> <p>Enable must be selected in Functions/Print Statistics/Usage Report</p>
Reset Group Counter	Execute	<p>Resets the main counter to zero.</p> <p>When executing this menu, resets the main counter to zero and exits from the menu.</p> <p>Enable must be selected in Functions/Print Statistics/Usage Report.</p>
Group Counter	<b>Enable/Disable</b>	<p>Specifies if the Group counter is displayed in the Usage Report Print.</p> <p><b>Enable:</b> Displayed,</p> <p><b>Disable:</b> Not displayed.</p> <p>Conditions for display:</p> <p>Enable must be selected in Functions/Print Statistics/Usage Report.</p>
Usage Report	<b>Enable/Disable</b>	<p>Enables/Disables the printing of the Usage Report.</p> <p>When changing a setting value, the printer is rebooted.</p>
Change Password		<p>Changes the password.</p> <p>Enable must be selected in Functions/Print Statistics/Usage Report</p>

ITEM	SETTINGS	EXPLANATION
New Password	xxxx	Sets a new password to enter Print Statistics menu.
Verify Password	xxxx	Re-enter new password set to enter Print Statistics set in New Password for confirmation.

## Administrator (Boot) Menu

This menu is only accessible to System Administrators. In order to gain access to this menu, follow the instructions in ["How to Change the Settings: Administrator" on page 24.](#)

This menu is in English only (default settings in bold type).

### Parallel Setup

This menu controls the operation of the printer's Parallel data interface.

ITEM	SETTINGS	EXPLANATION
Enter Password	xxxxxxxxxxxx	Enter a password to gain entry to the Admin menu. Password should be from 6 to 12 digits of alpha/numeric characters (or mix) The default value is "aaaaaa" The printer will restart after the Boot Menu.
Parallel	<b>Enable</b> / Disable	Enables or disables the parallel port.
Bi-direction	<b>Enable</b> / Disable	ENABLE/DISABLE the bi-directional capability of the parallel interface.
Ecp	<b>Enable</b> / Disable	Extended Capabilities Port, enables/disables this function.
Ack Width	<b>Narrow</b> / Medium / Wide	Sets ACK width for compatible reception. = 0.5µs = 1.0µs = 3.0µs

ITEM	SETTINGS	EXPLANATION
Ack / Busy Timing	<b>Ack In Busy</b> / Ack While Busy	Sets the order to output the BUSY and ACK signal for compatible reception.
I-prime	<b>Disable</b> / 3μsec/50μsec	Sets time to enable/disable I-prime signal
Offline Receive	Enable / <b>Disable</b>	To Enable/disable of this function. When set to Enable, the interface retains a receive possible state even when switching to Offline. Interface sends the BUSY signal only when the receive buffer is full or a service call occurs.

## USB Setup

This menu controls the operation of the printer's USB data interface.

ITEM	SETTINGS	EXPLANATION
Usb	<b>Enable</b> / Disable	ENABLES / DISABLES the USB port.
Speed	12 / <b>480</b> Mbps	Selects the interface speed. After setting change the menu, the printer restarts on exit.
Soft Reset	Enable / <b>Disable</b>	Enables or disables the SOFT RESET command.
Offline Receive	Enable / <b>Disable</b>	OFFLINE RECEIVE.
Serial Number	<b>Enable</b> / Disable	Specifies whether to ENABLE or DISABLE a USB serial number.  The USB serial number is used to identify the USB device connected to your PC.

When you have changed any settings in the USB MENU, turn the printer **OFF**, then **ON** again.

## Security Setup

Only available when a Hard Disk (option) is fitted.

ITEM	SETTINGS	EXPLANATION
Job Limitations	<b>Off</b> Encrypted Job	Job limitation mode control. Jobs other than specified ones are rejected.
Reset Cipher Key	Execute	Resets a cipher key to be used on an encrypted hard disk.  When this processing is done, all data stored on the hard disk cannot be restored.  After execution, the following confirmation messages will appear. <b>Are You Sure? es / No</b> <b>No</b> - display returns to the previous menu. <b>Yes =</b> , the printer automatically reboots and the cipher key reset is executed.

## Storage System

Only available when a Hard Disk (option) is fitted.

ITEM	SETTINGS	EXPLANATION
Check File System	Execute	Resolves mismatch between actual memory and displayed memory available in a file system. Performs administration data (FAT information) recovery. Performs recovery only for an HDD.
Check All Sectors	Execute	Performs recovery of defective HDD sector information and a file system mismatch mentioned above. The target device is only a HDD and it takes 30 to 40 minutes to complete this function for an HDD of 10GB.

ITEM	SETTINGS	EXPLANATION
Enable HDD	Yes No	<p>Even if a machine is inoperable at installation because of a faulty HDD, the machine can be made operable by setting this parameter to <b>No</b> (ignores the existence of the HDD).</p> <p>When No is set, access to a HDD results in <b>FAIL</b> because the HDD is regarded as not attached.</p> <p>After setting change and exit from the menu, the printer will restart.</p>
Erase HDD	Execute	<p>Deletion of all data stored in the hard disk. DoD 5220.22-M sanitizing formula is used for clearing the disk. The machine will restart after changing setup. The following message appears after pressing the Enter switch.</p> <p><b>Are You Sure? Yes / No</b></p> <p><b>NO</b> = return to the source menu</p> <p><b>Yes</b> = the procedure for clearing disk starts immediately after the machine reboots.</p> <p>If the <b>Cancel</b> button is held down during erasing, the following confirmation messages will appear to discontinue processing.</p> <p><b>Do You Wish to Cancel? Yes / No</b></p> <p><b>NO</b>= procedure will continue.</p> <p><b>YES</b> = procedure will discontinue.</p>
Enable initialization	No Yes	Prevents a setting change accompanying initialization of Block Device (HDD,FLASH).



## Power Setup

ITEM	SETTINGS	EXPLANATION
Power Save	<b>Enable</b> Disable	Sets Enable/Disable of Power Save Mode.

## Language Setup

ITEM	SETTINGS	EXPLANATION
Language initialize	Execute	Initializes the message file loaded in FLASH. When you press the <b>Enter</b> button, the following message, requesting confirmation, will appear, <b>Are You Sure? Yes / No</b> <b>NO</b> = return to the source menu. The procedure for clearing the disk will start immediately after the menu and rebooting.

# Available Options

---

See the instructions supplied with the options.

## Duplex (two-sided printing) Unit \_\_\_\_\_

**OKI P/N 43830005**

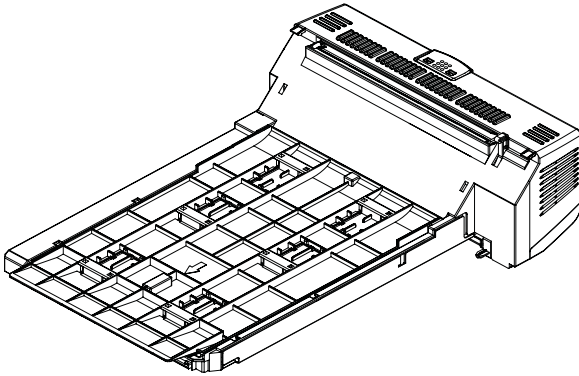

The duplex unit adds the function of two-sided printing, using less paper and making large documents easier to handle. It also enables booklet printing, which uses even less paper and makes large documents even easier to handle.

The duplex unit slides straight into the rear of the printer and requires no tools to install.

## Additional RAM Memory \_\_\_\_\_

**OKI P/N 43363304 (256 MB), 43363305 (512 MB)**

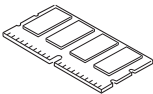

The basic printer model comes equipped with 256MB of main memory. This can be upgraded with an additional memory board of 256MB or 512MB, giving a maximum total memory capacity of 768MB.

Installation takes a few minutes, and requires a medium size cross-head (philips type) screwdriver.

# Hard Disk Drive

---

**Oki P/N 41376046**

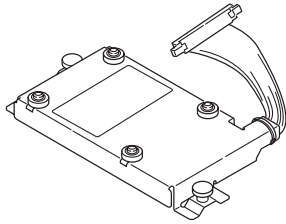

The optional internal hard disk drive (HDD) enables collating of printed pages and can be used to store overlays and macros, fonts, and secure or proof documents waiting to be printed.

Installation takes a few minutes, and requires a medium size cross-head (philips type) screwdriver.

# Additional Paper Tray(s)

---

**Oki P/N 3855101**

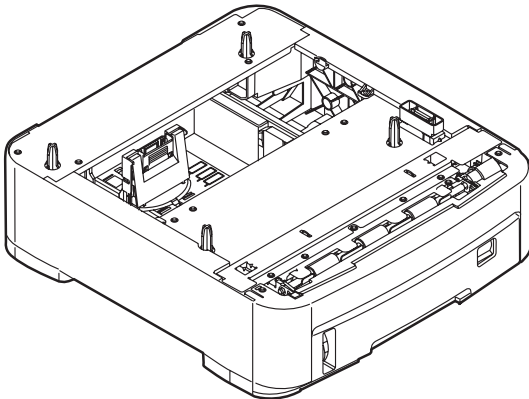

The paper trays hold 530 sheets of 20-lb. US Bond (75 g/m<sup>2</sup>) paper and require no tools to install

# Clearing Paper Jams

Provided that you follow the recommendations in this guide on the use of print media, and you keep the media in good condition prior to use, your printer should give years of reliable service. However, paper jams occasionally do occur, and this section explains how to clear them quickly and simply.

Jams can occur due to paper misfeeding from a paper tray or at any point on the paper path. When a jam occurs, the printer immediately stops, and the Status Panel (together with the Status Monitor) informs you. If printing multiple pages (or copies), do not assume that, having cleared an obvious sheet, others will not also be stopped somewhere along the path. These must also be removed in order to restore normal operation.

## Major Printer Components and Paper Path

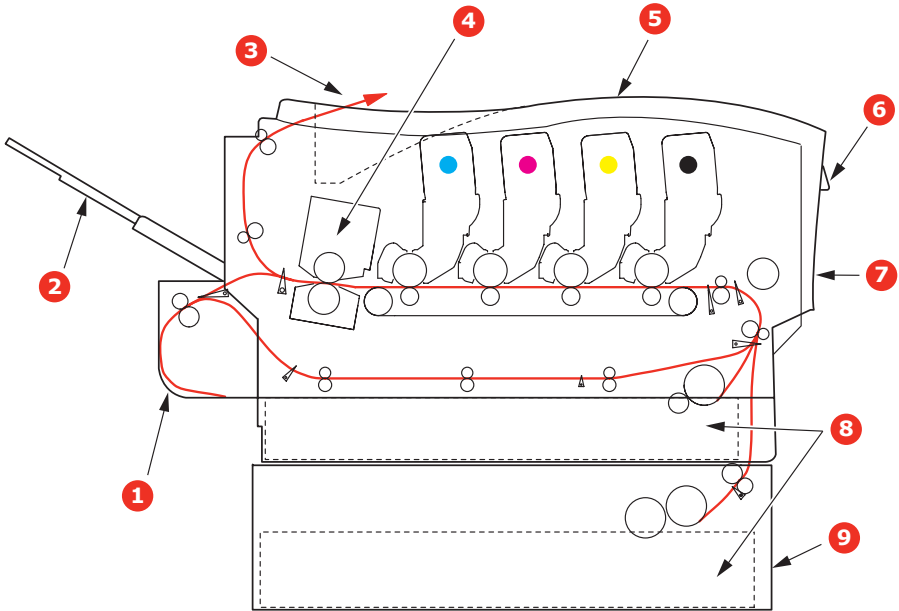

**1. Duplex unit (if fitted).**

**2. Face-up stacker.**

**3. Paper exit.**

**4. Fuser unit**

**5. Top cover.**

**6. Operator panel.**

**7. Front cover.**

**8. Paper tray.**

**9. Additional paper tray (if fitted)**

# Paper Sensor Error Codes

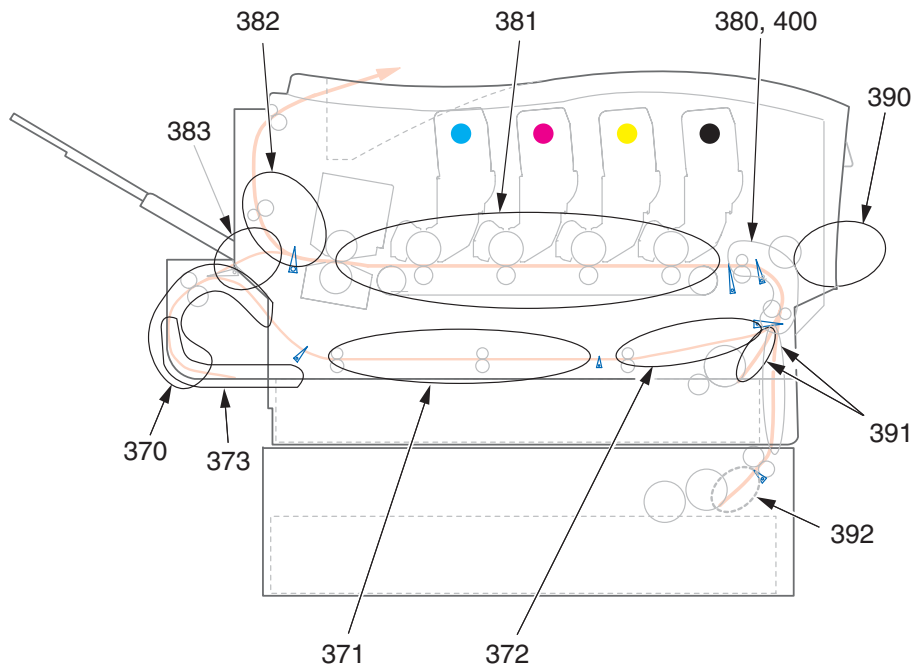

CODE #	LOCATION	CODE #	LOCATION
370	Duplex unit *	382	Paper exit
371	Duplex unit *	383	Duplex unit *
372	Duplex unit *	390	MP Tray
373	Duplex unit *	391	Paper Tray
380	Paper feed	392	2 <sup>nd</sup> Paper tray *
381	Paper path	400	Paper size

\* (if fitted).

1. If a sheet is well advanced out of the top of the printer, simply grip it and pull gently to draw it fully out. If it does not remove easily, do not use excessive force. It can be removed from the rear later.

2. Press the cover release and open the printer's top cover fully.

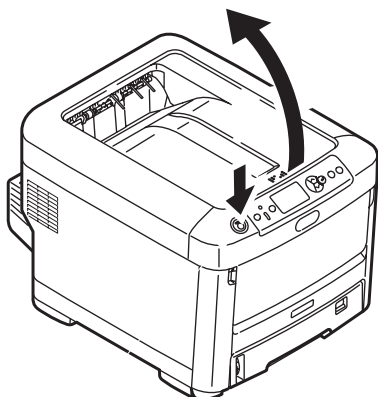

## WARNING!

**If the printer has been powered on, the fuser will be hot. This area is clearly labelled. Do not touch.**

3. Note the positions of the four toner cartridges (a) and image drums (b). It is essential that they go back in the same order.

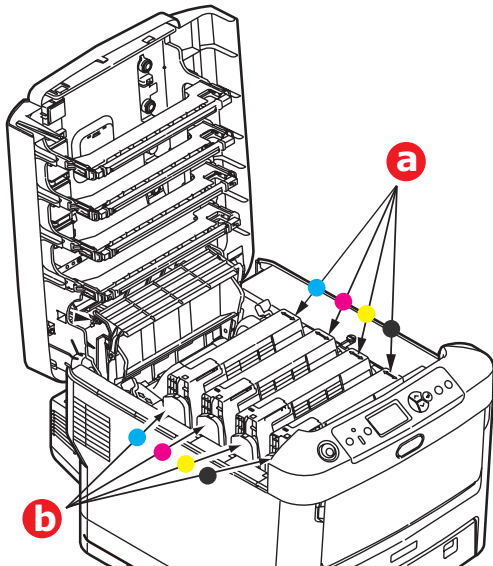

It will be necessary to remove the four image drums to gain access to the paper path.

4. Holding it by its top centre, lift the cyan image drum, complete with its toner cartridge, up and out of the printer.

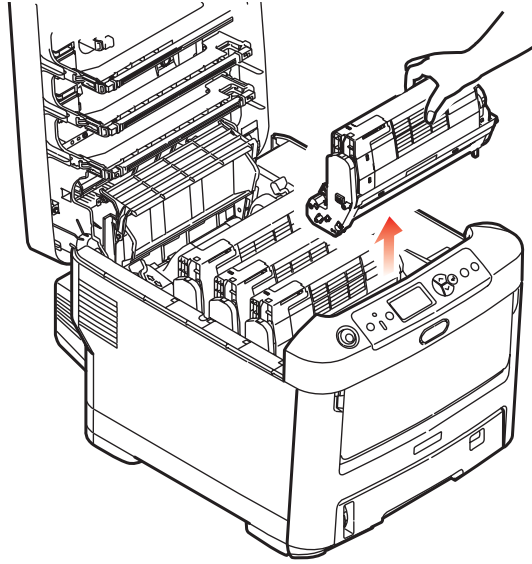

5. Put the assembly down gently onto a piece of paper to prevent toner from marking your furniture and to avoid damaging the green drum surface, and cover.

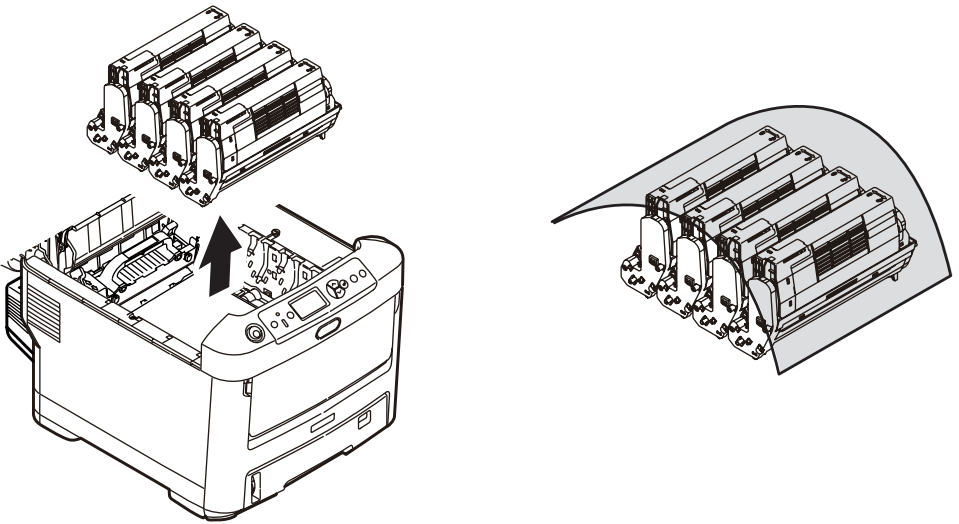

### CAUTION!

**The green image drum surface at the base of the Image Drum is very delicate and light sensitive. Do not touch it and do not expose it to normal room light for more than 5 minutes.**

6. Repeat this removal procedure for each of the remaining image drum units.



7. Look into the printer to check whether any sheets of paper are visible on any part of the belt unit.

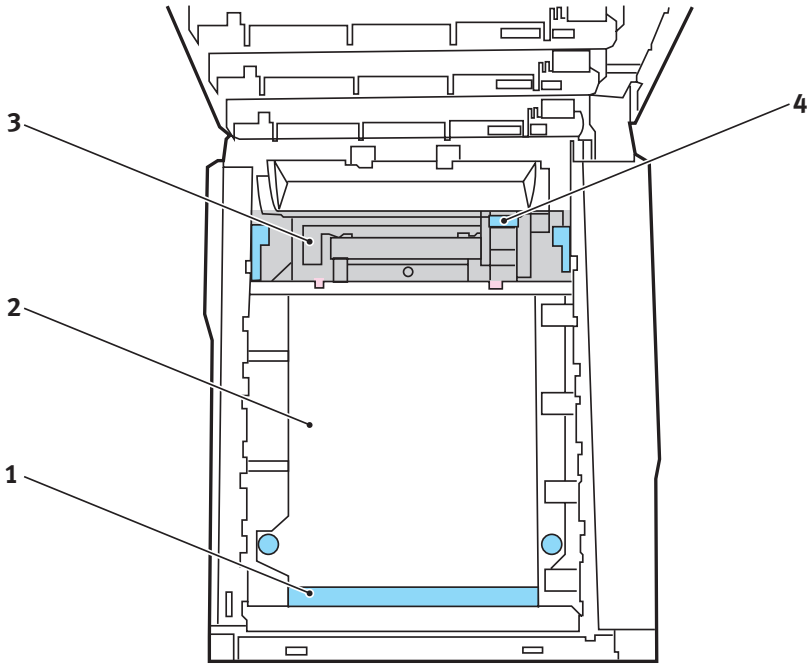

### CAUTION!

**Do not use any sharp or abrasive objects to separate sheets from the belt. This may damage the belt surface.**

- (a) To remove a sheet with its leading edge at the front of the belt (1), carefully lift the sheet from the belt and pull it

forwards into the internal drum cavity and withdraw the sheet.

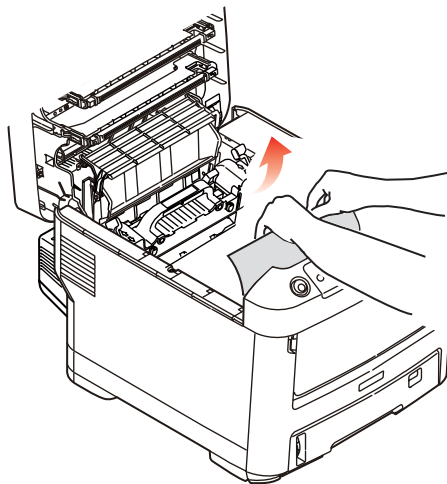

- (b) To remove a sheet from the central area of the belt (2), carefully separate the sheet from the belt surface and withdraw the sheet.

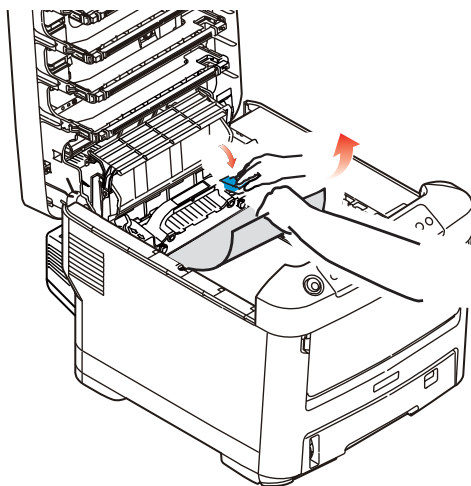

- (c) To remove a sheet just entering the fuser (3), separate the trailing edge of the sheet from the belt, push the fuser pressure release lever (4) towards the front and down to release the fuser's grip on the sheet, and withdraw the

sheet through the drum cavity area. Then allow the pressure release lever to rise again.

**Note:**

If the sheet is well advanced into the fuser (only a short length is still visible), do not attempt to pull it back. Follow the next steps.

- (d) To remove a sheet in the fuser; push the two retaining levers (a) towards the rear of the printer to release the fuser. Withdraw the fuser unit using the handle (b).

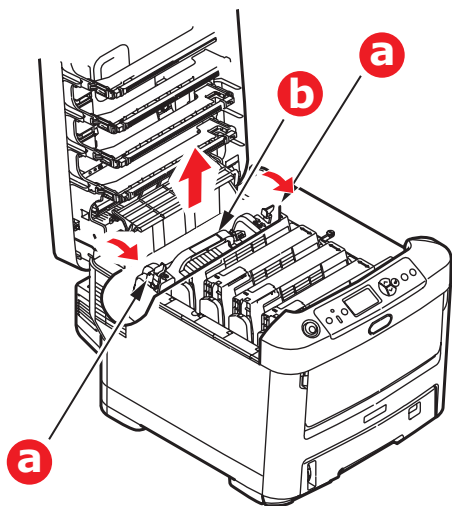

Press release lever (c) and pull the trapped paper from the fuser.

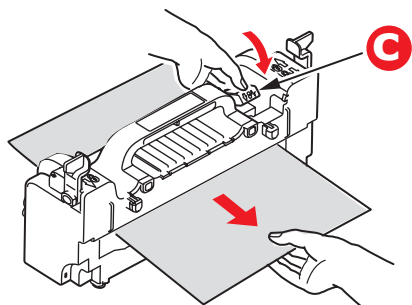

- (e) Replace fuser unit into the machine and move locking levers (a) toward the rear of the machine.

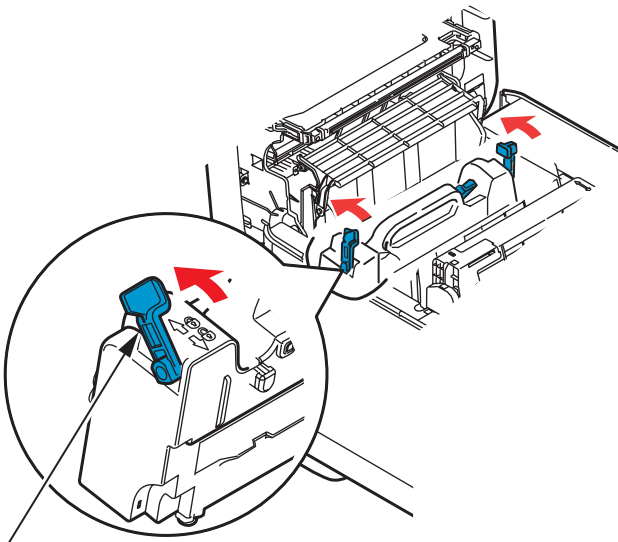
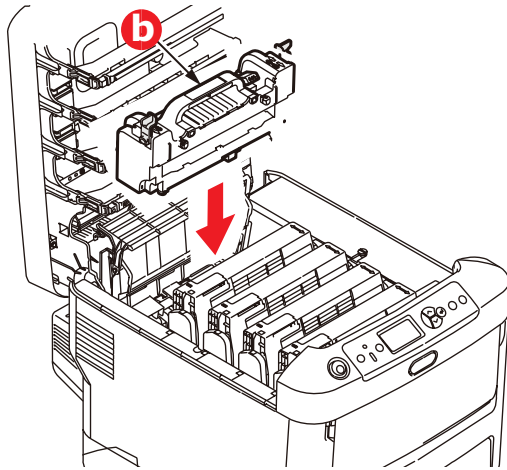

8. Starting with the cyan image drum unit nearest the fuser, replace the four image drums into the drum cavity, making sure to locate them in the correct order.

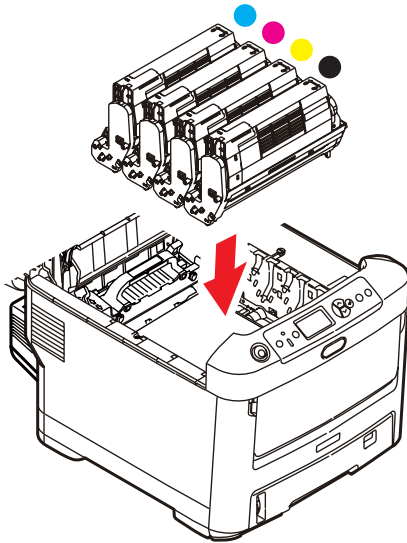

Holding the complete assembly by its top centre, lower it into place in the printer, locating the pegs at each end into their slots in the sides of the printer cavity.

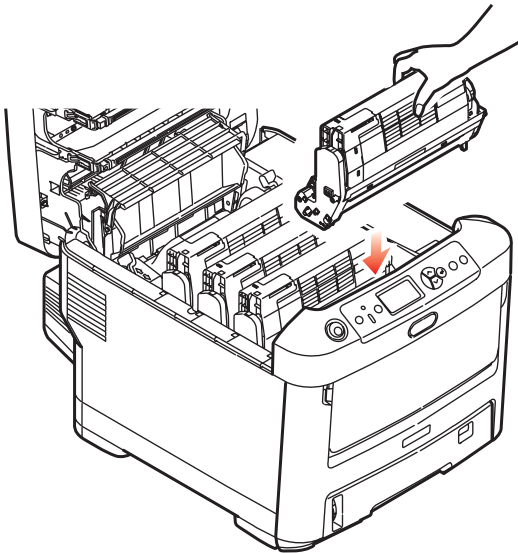

9. Lower the top cover but do not press down to latch it closed yet. This will protect the drums from excessive exposure to room lighting while you check the remaining areas for jammed sheets.
10. Open the rear exit tray (a) and check for a sheet of paper in the rear path area (b).

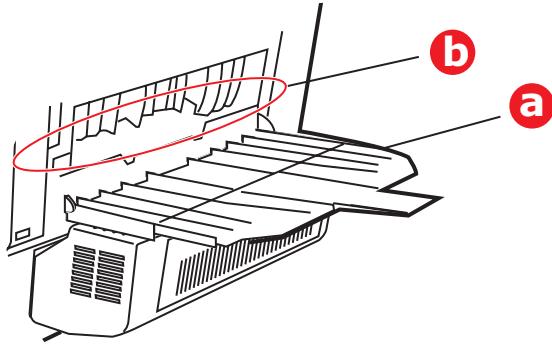

- Pull out any sheets found in this area.
- If the sheet is low down in this area and difficult to remove, it is probably still gripped by the fuser. In this case raise the top cover, reach around and press down on the fuser pressure release lever (a).

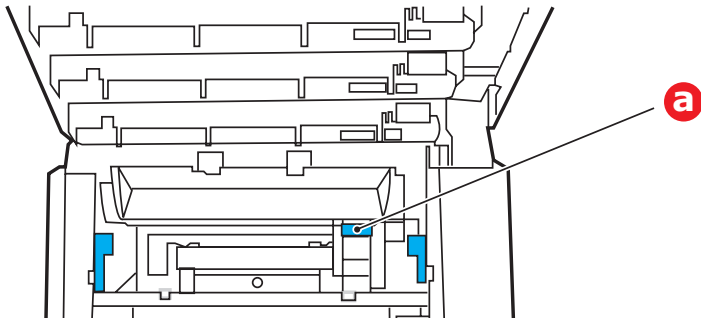

11. If you are not using the rear exit tray, close it once any paper has been removed from this area.

- 12.** If a duplex unit is fitted, lift lever (a) and lower the duplex unit cover and pull out any sheets found in this area. Close the duplex unit cover

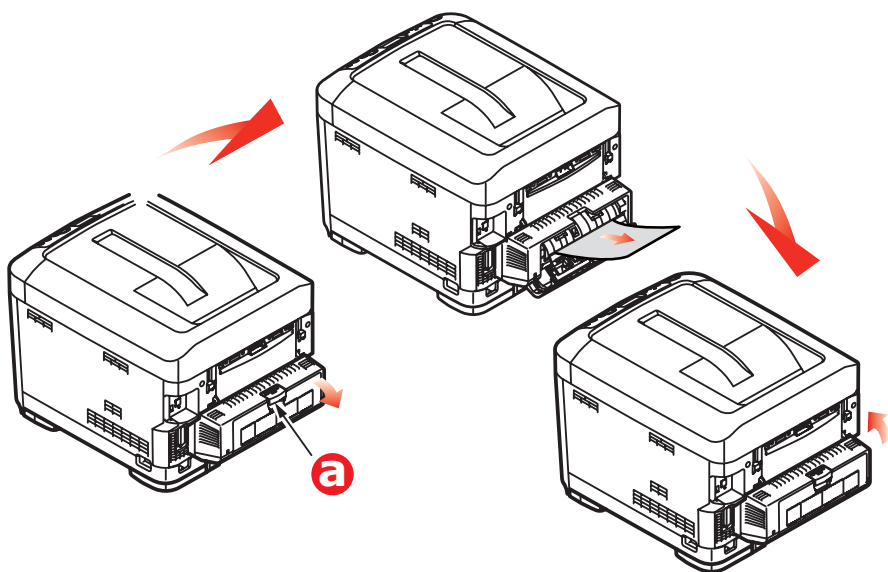

- 13.** Pull down the MP Tray using the depressions (b). Lift the front cover release lever and lower the front cover.

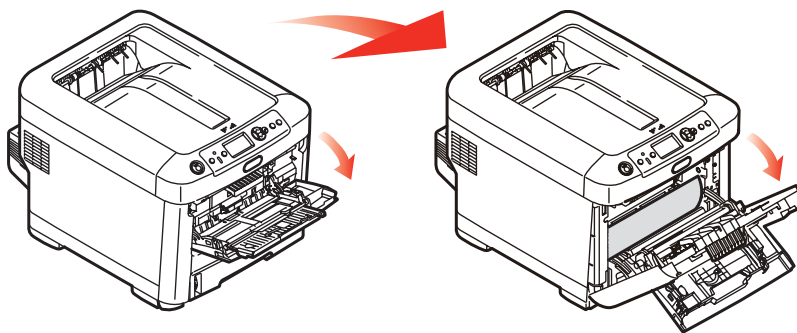

- 14.** Check inside the cover for sheets in this area and remove any that you find, then close the cover.

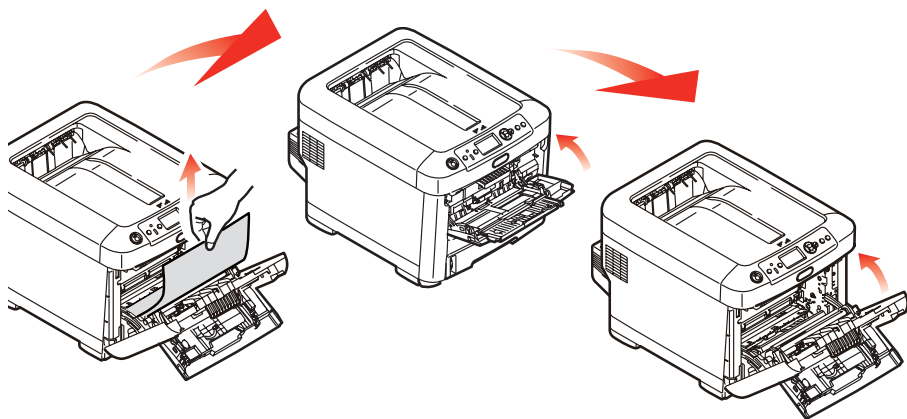

- 15.** Pull out the paper tray and ensure that all paper is stacked properly, is undamaged, and that the paper guides are properly positioned against the edges of the paper stack. When satisfied, replace the tray.

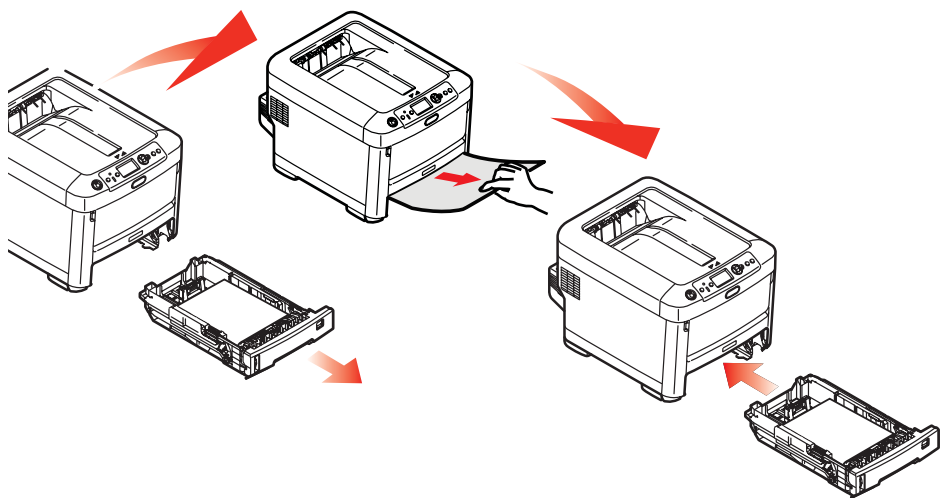

- 16.** Finally, close the top cover and press down firmly so that the cover latches closed.

When the jam has been cleared, if Jam Recovery is set to ON in the System Configuration Menu, the printer will attempt to reprint any pages lost due to paper jams.



# Replacing Consumables and Maintenance Items

---

## Order Information

Only use genuine Oki Original products to ensure the best quality and performance from your hardware. Non Oki Original products may adversely affect your printer's performance and invalidate your warranty.

ITEM	LIFE	ORDER NO.
Toner, black	10,000 Letter @ 5%	43866104
Toner, cyan	10,000 Letter @ 5%	43866103
Toner, magenta	10,000 Letter @ 5%	43866102
Toner, yellow	10,000 Letter @ 5%	43866101
Image drum, black	20,000 Letter pages*	43913804
Image drum, cyan	20,000 Letter pages*	43913803
Image drum, magenta	20,000 Letter pages*	43913802
Image drum, yellow	20,000 Letter pages*	43913801
Fuser, 120V** Fuser, 230V	60,000 Letter pages*	43854901 43854902
Transfer belt**	60,000 Letter @ 3/job	43363411

\* Based on continuous print.

\*\* Fusers and transfer belts are replaceable maintenance items. They are warranted against defects for 90 days. When the printer display indicates that they are near end of life, a replacement must be purchased.

# Toner Cartridge Replacement \_\_\_\_\_

**Note:**

When the LCD display indicates TONER LOW, or if print appears faded, first open the top cover and try tapping the cartridge a few times to evenly distribute the toner powder. This will enable you to obtain the best "yield" from your toner cartridge.

**CAUTION!**

**To avoid toner wastage and possible toner sensor errors, do not change the toner cartridge(s) until "TONER EMPTY" is displayed.**

Have a sheet of paper handy so that you have somewhere to place the used cartridge while you install the new one.

Dispose of the old cartridge responsibly, inside the pack that the new one came in. Follow any regulations, recommendations, etc., which may be in force concerning waste recycling.

If you do spill any toner powder, lightly brush it off. If this is not enough, use a cool, damp cloth to remove any residue.

Do not use hot water, and never use solvents of any kind. They will make stains permanent.

**WARNING!**

**If you inhale any toner or get it in your eyes, drink a little water or bathe your eyes liberally in cold water. Seek medical attention immediately.**

1. Press the cover release and open the printer's top cover fully.

**WARNING**

**If the printer has been powered on, the fuser may be hot. This area is clearly labelled. Do not touch.**

2. Note the positions of the four cartridges.

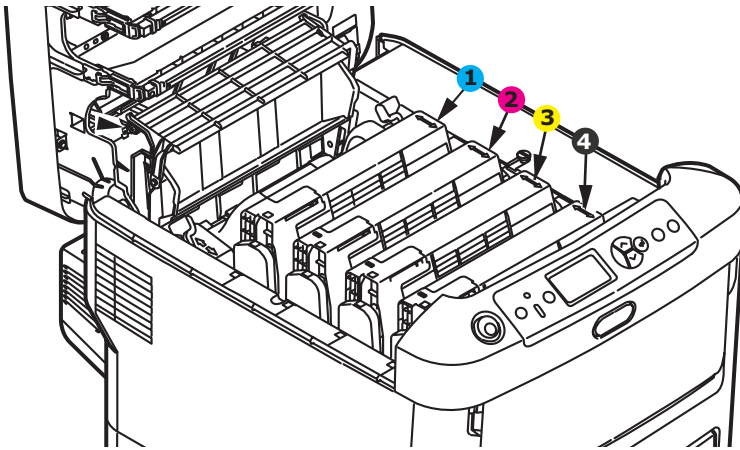

- 1 = cyan
- 2 = magenta
- 3 = yellow
- 4 = black

(a) Pull the colored toner release lever on the cartridge to be replaced fully towards the front of the printer.

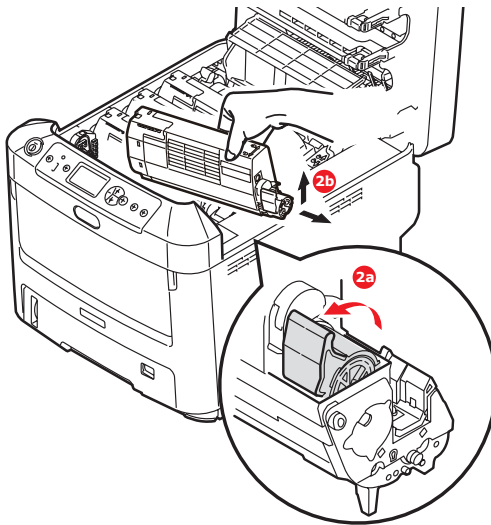

(b) Lift the right-hand end of the cartridge and then draw the cartridge to the right to release the left-hand end as shown, and withdraw the toner cartridge out of the printer.

3. Clean the top of the ID unit with a clean, lint free cloth.

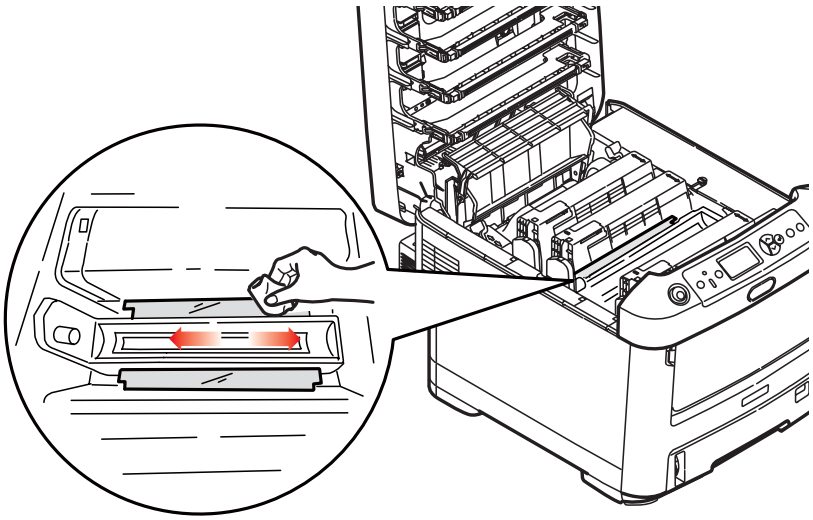

4. Put the cartridge down gently onto a piece of paper to prevent toner from marking your furniture.
5. Remove the new cartridge from its box but leave its wrapping material in place for the moment.
6. Gently shake the new cartridge from end to end several times to loosen and distribute the toner evenly inside the cartridge.

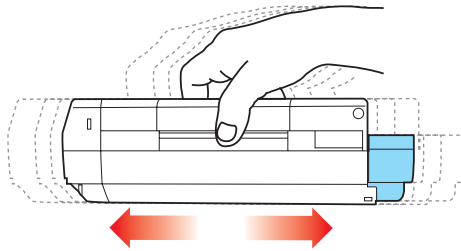

7. Remove the wrapping material and peel off the adhesive tape from the underside of the cartridge.

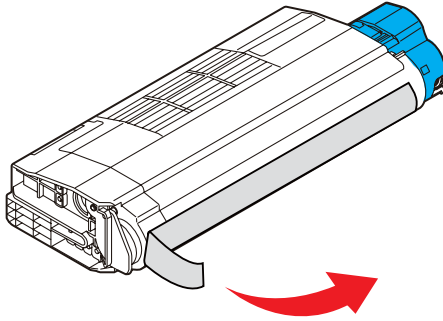

8. Holding the cartridge by its top centre with the colored lever to the right, lower it into the printer over the image drum unit from which the old cartridge was removed.
9. Insert the left end of the cartridge into the top of the image drum unit first, pushing it against the spring on the drum

unit, then lower the right end of the cartridge down onto the image drum unit.

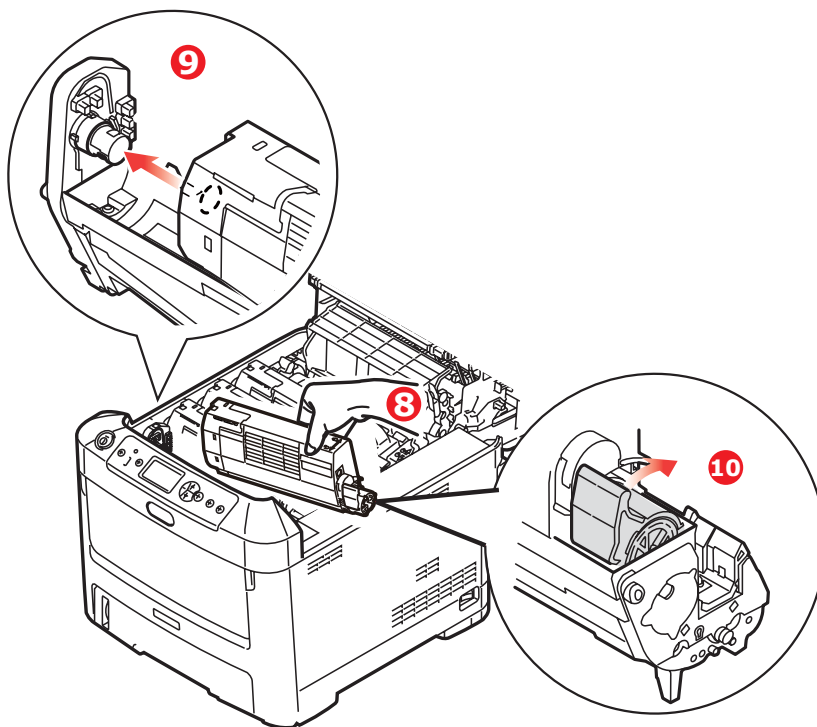

- 10.** Pressing gently down on the cartridge to ensure that it is firmly seated, push the colored lever towards the rear of the printer. This will lock the cartridge into place and release toner into the image drum unit.

**11.** Gently wipe the LED head surface with soft tissue.

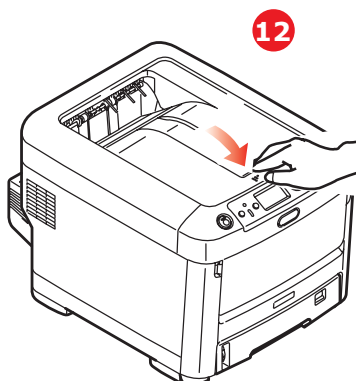
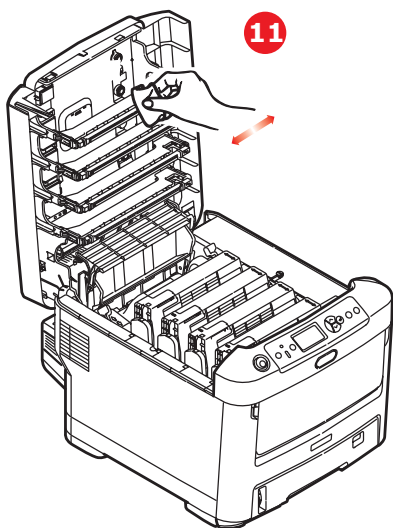

### **CAUTION!**

**To avoid toner wastage and possible toner sensor errors, do not change the toner cartridge(s) until "TONER EMPTY" is displayed.**

**12.** Finally, close the top cover and press down firmly at both sides so that the cover latches closed.

# Image Drum Replacement. \_\_\_\_\_

## CAUTION!



**Static sensitive devices, handle with care.**

The printer contains four image drums: cyan, magenta, yellow and black.

1. Press the cover release and open the printer's top cover fully.

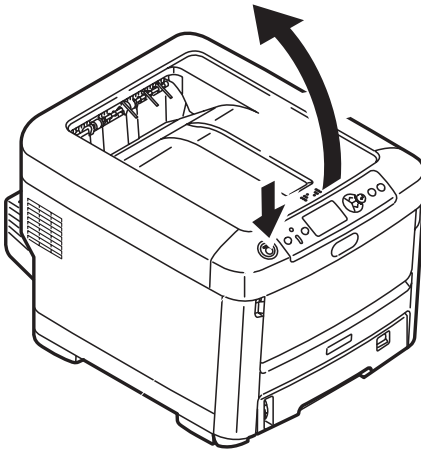

## WARNING!

**If the printer has been powered on, the fuser will be hot. This area is clearly labelled. Do not touch.**



2. Note the positions of the four toner cartridges (a) and image drums (b). It is essential that they go back in the same order.

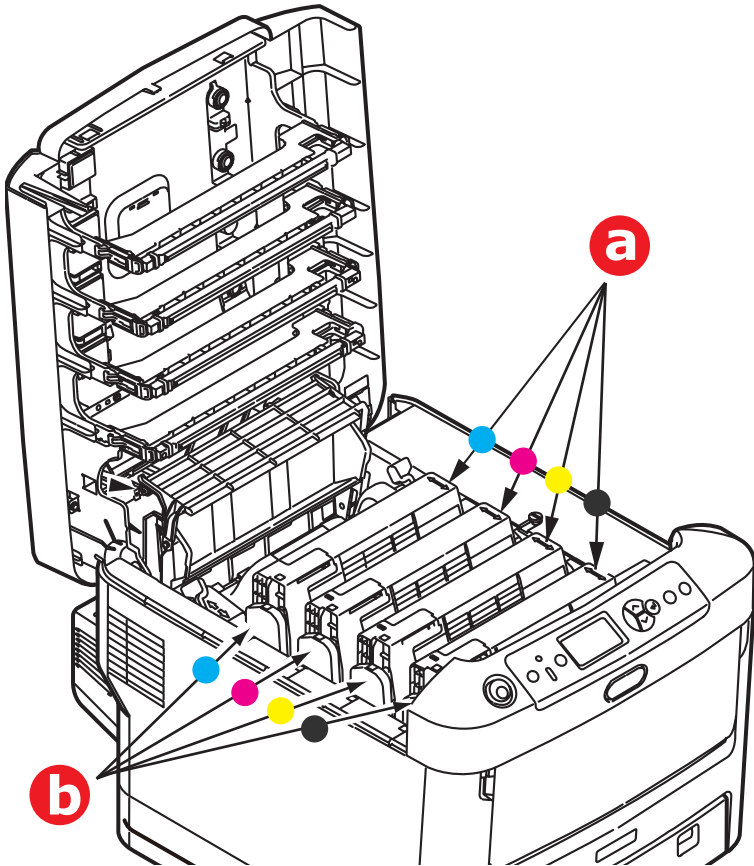

3. Holding it by its top centre, lift the image drum, complete with its toner cartridge, up and out of the printer.

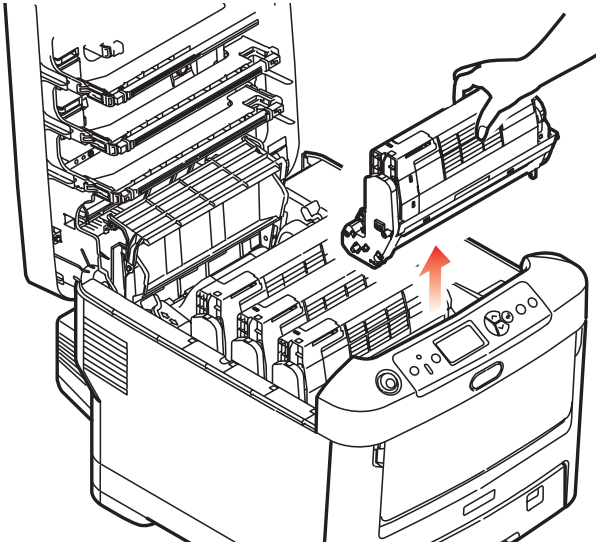

4. Put the assembly down gently onto a piece of paper to prevent toner from marking your furniture and to avoid damaging the green drum surface.

### CAUTION!

**The green image drum surface at the base of the ID unit is very delicate and light sensitive. Do not touch it and do not expose it to normal room light for more than 5 minutes. If the drum unit needs to be out of the printer for longer than this, please wrap the cartridge inside a black plastic bag to keep it away from light. Never expose the drum to direct sunlight or very bright room lighting.**

5. With the colored toner release lever (1) to the right, pull the lever towards you. This will release the bond between the toner cartridge and the image drum unit.

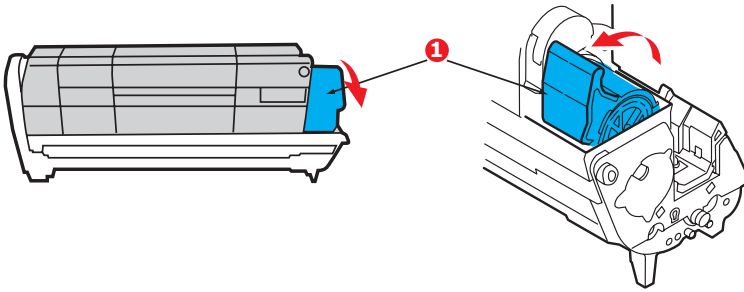

6. Lift the right-hand end of the toner cartridge (1) and then draw the cartridge to the right to release the left-hand end as shown (2), and withdraw the toner cartridge out of the image drum cartridge. Place the cartridge on a piece of paper to avoid marking your furniture.

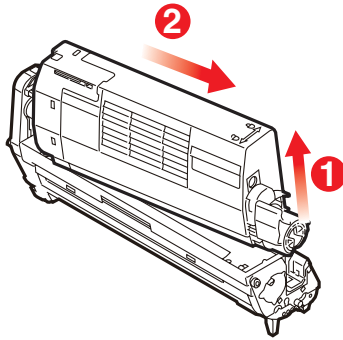

7. Take the new image drum cartridge out of its packaging and place it on the piece of paper where the old cartridge was placed. Keep it the same way round as the old unit. Pack the old cartridge inside the packaging material for disposal.

**Note:**

Follow instructions that come with the new image drum for additional information such as the removal of packaging material etc.

- 8.** Place the toner cartridge onto the new image drum cartridge as shown. Push the left end in first, and then lower the right end in. (It is not necessary to fit a new toner cartridge at this time unless the remaining toner level is very low.)

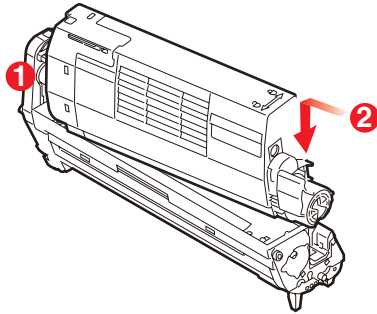

- 9.** Push the colored release lever away from you to lock the toner cartridge onto the new image drum unit and release toner into it.

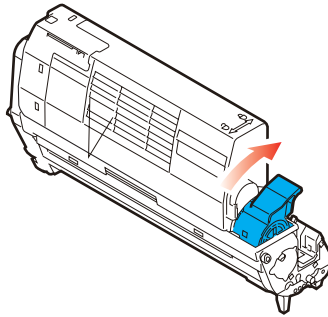

10. Holding the complete assembly by its top centre, lower it into place in the printer, locating the pegs at each end into their slots in the sides of the printer cavity.

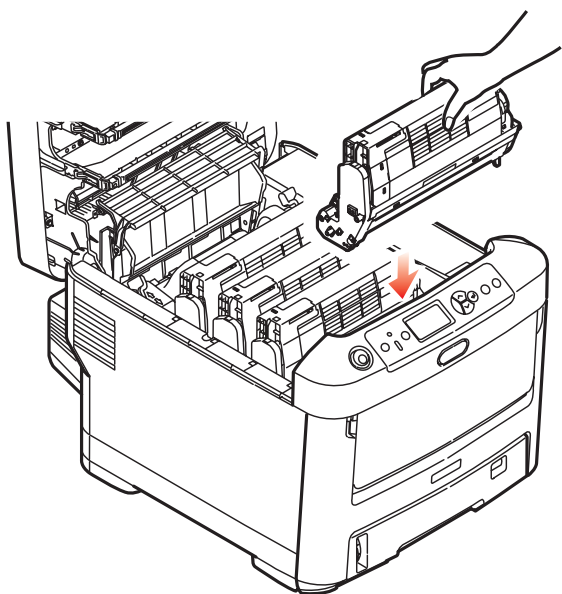

11. Finally, close the top cover and press down firmly at both sides so that the cover latches closed.

**Note:**

If you need to return or transport your printer for any reason, please make sure you remove the image drum unit beforehand and place in the bag provided. This is to avoid toner spillage.

## Replacing the Transfer Belt Unit \_\_\_\_\_

The belt unit is located under the four image drums. This unit requires replacement approximately every 60,000 pages.

Switch off the printer and allow the fuser to cool for about 10 minutes before opening the cover.

1. Press the cover release and open the printer's top cover fully.

## WARNING!

**If the printer has been powered on, the fuser will be hot. This area is clearly labelled. Do not touch.**

2. Note the positions of the four toner cartridges (a) and image drums (b). It is essential that they go back in the same order.

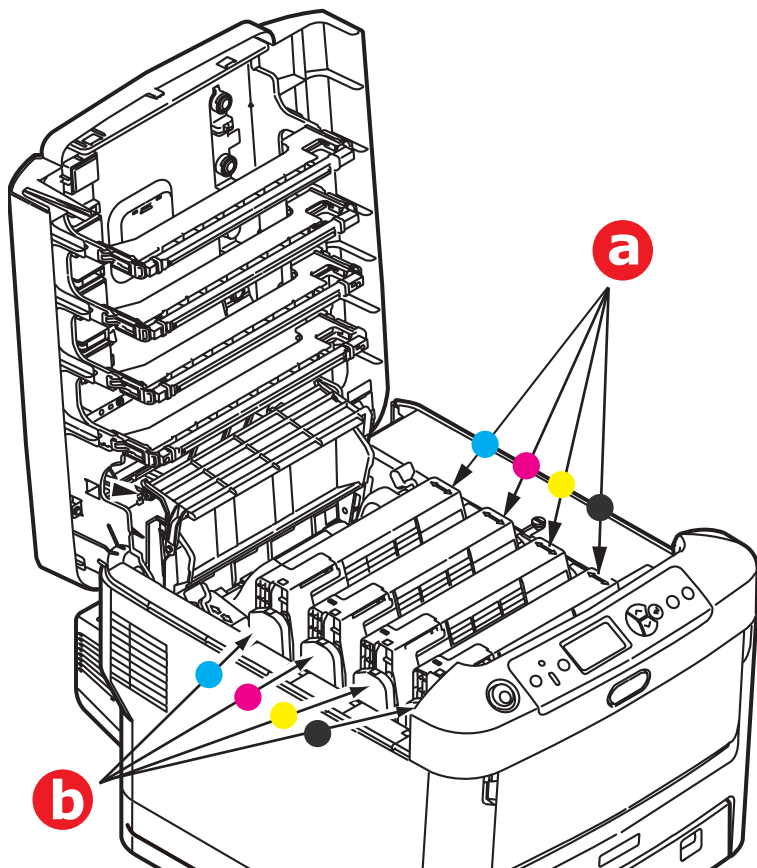

3. Lift each of the image drum units out of the printer and place them in a safe place away from direct sources of heat and light.

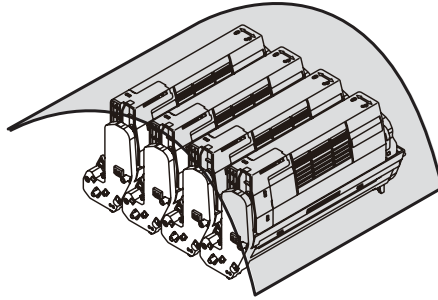

### **CAUTION!**

**The green image drum surface at the base of each cartridge is very delicate and light sensitive. Do not touch it and do not expose it to normal room light for more than 5 minutes. If the drum unit needs to be out of the printer for longer than this, please wrap the cartridge inside a black plastic bag to keep it away from light. Never expose the drum to direct sunlight or very bright room lighting.**

4. Locate the two fasteners (a) at each side of the belt and the lifting bar (b) at the front end.

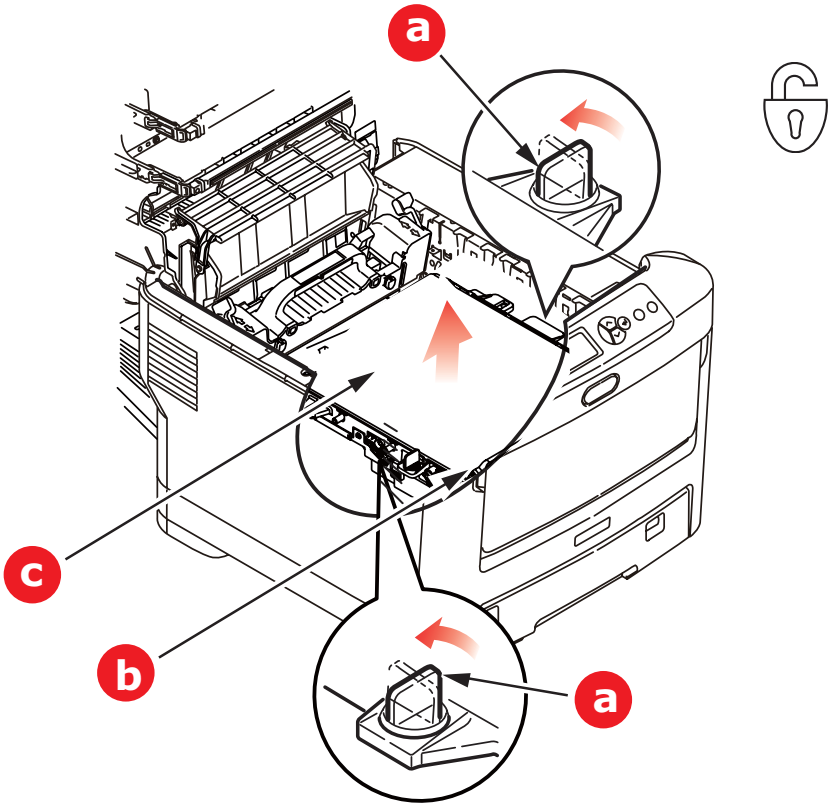

5. Turn the two fasteners 90° to the left. This will release the belt from the printer chassis.
6. Pull the lifting bar (b) upwards so that the belt tilts up towards the front, and withdraw the belt unit (c) from the printer.
7. Lower the new belt unit into place, with the lifting bar at the front and the drive gear towards the rear of the printer. Locate the drive gear into the gear inside the printer by the



rear left corner of the unit, and lower the belt unit flat inside the printer.

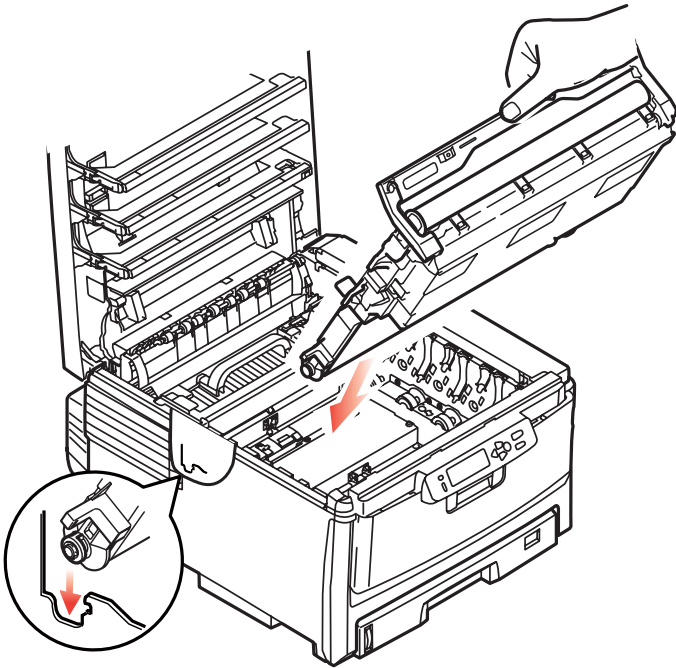

- 8.** Turn the two fasteners (a) 90° to the right until they lock. This will secure the belt unit in place.

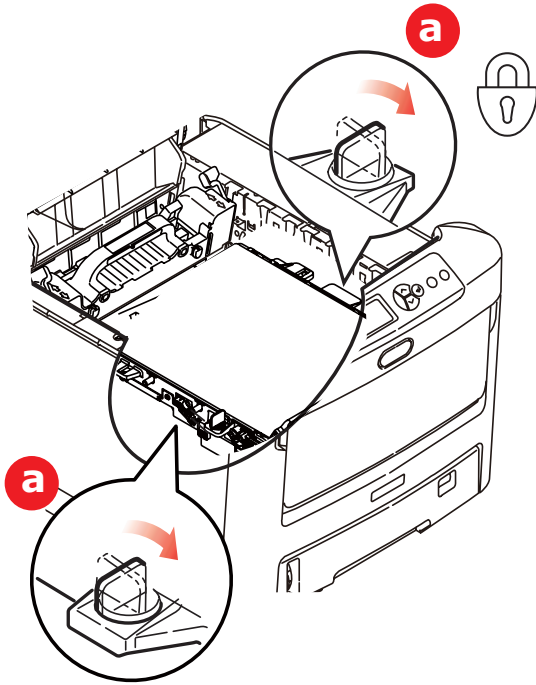

- 9.** Replace the four image drums, complete with their toner cartridges, into the printer in the same sequence as they came out: cyan (nearest the rear), magenta, yellow and black (nearest the front).
- 10.** Finally, close the top cover and press down firmly at both sides so that the cover latches closed.

# Fuser Replacement

The fuser is located inside the printer just behind the four image drum units.

## WARNING

**If the printer has recently been powered on, some fuser components will be very hot. Handle the fuser with extreme care, holding it only by its handle, which will only be mildly warm to the touch. A warning label clearly indicates the area. If in doubt, switch the printer off and wait at least 10 minutes for the fuser to cool before opening the printer cover.**

1. Press the cover release and open the printer's top cover fully.
2. Identify the fuser handle (a) on the top of the fuser unit.

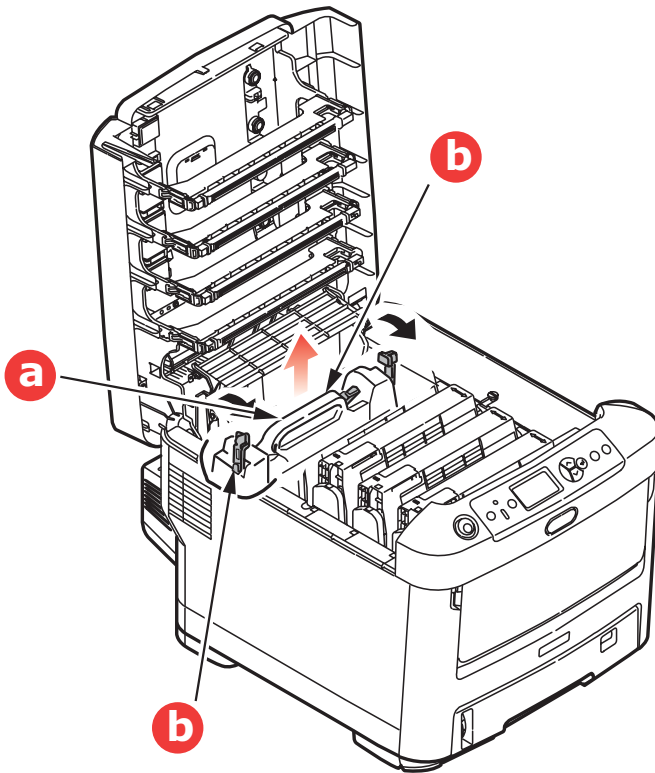

3. Pull the two fuser retaining levers (b) towards the front of the printer so that they are fully upright.
4. Holding the fuser by its handle (a), lift the fuser straight up and out of the printer. If the fuser is still warm, place it on a flat surface which will not be damaged by heat.
5. Remove the new fuser from its packaging and remove the transit material.
6. Holding the new fuser by its handle, make sure that it is the correct way round. The retaining levers (a) should be fully upright, and the two locating lugs (b) should be towards you.

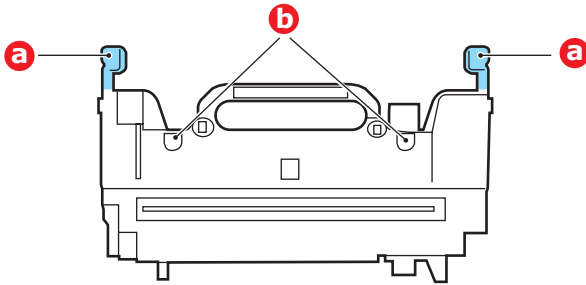

7. Lower the fuser into the printer, locating the two lugs (b) into their slots in the metal partition which separates the fuser area from the image drums.

8. Push the two retaining levers (a) towards the rear of the printer to lock the fuser in place.

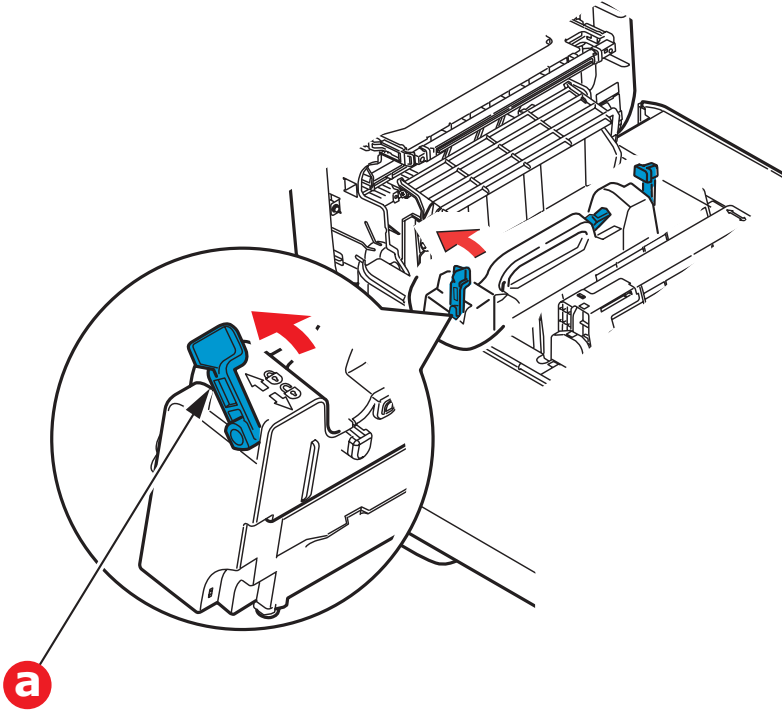

9. Finally, close the top cover and press down firmly at both sides so that the cover latches closed.

# Cleaning the LED Head

---

Clean the LED heads when printing does not come out clearly, has white lines or when text is blurred.

1. Switch off the printer.
2. Open the top cover.

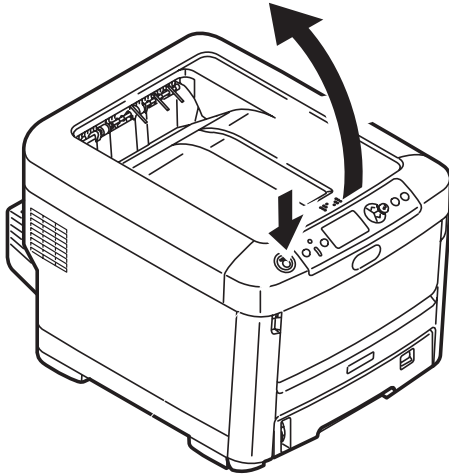

3. Gently wipe the LED head surface with a soft tissue

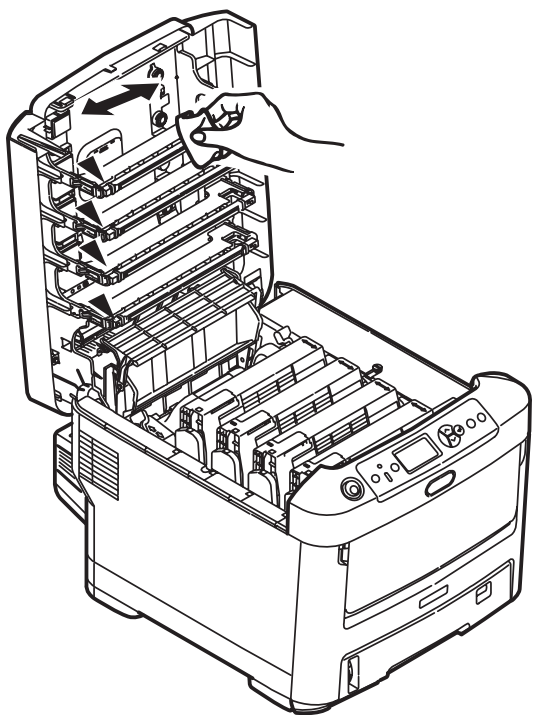

### **CAUTION!**

**Do not use methyl alcohol or other solvents on the LED head as damage to the lens surface will occur.**

4. Close the top cover.

# Utilities

---

## Summary of Utilities Provided \_\_\_\_\_

### Utilities on the CD

For more information, click “Tell me more” on the Optional Utilities screen.

#### Windows

- **Admin Manager**  
For quick discovery and setup of the Oki network card in your printer. Runs directly off the CD.
- **Direct Network Printing Utility (LPR)**  
For printing on an Ethernet network without the need for a print server.
- **Network Extension**  
For use when your printer is connected over a TCP/IP network. Check the printer status and configuration from the Printer Properties tab in the printer driver.
- **Color Swatch Utility**  
Print a color swatch and use the indicated RGB values to set up the color(s) of your choice in your graphics/design software application.
- **PDF Print Direct**  
Print pdf files without first opening them in an application.
- **Display Language Utility**  
Use to change the language of the printer’s display.

#### Macintosh

- **Color Correct Utility**  
Fine tune the printer’s color settings (pallet color, gamma value/hue) and save them for future use.
- **Op Panel Language Utility**  
Use to change the language of the printer’s display.
- **Profile Assistant**  
Helps you to load and manage color profiles.
- **NIC Setup Utility**  
Use to set up the [printer network card.
- **Storage Device Manager**  
Requires the hard disk drive, optional on some models.



Download PCL macros, Postscript forms and bar codes to the printer hard disk drive for use in print jobs

- **Swatch Utility**

Print a color swatch and use the indicated RGB values to set up the color(s) of your choice in your graphics/design software application.

- **PS Gamma Adjuster**

Customize the CMYK data curves used with your printer driver. Once you have created the customized curve in the utility, you must save the curve (new PPD) and reconfigure your printer driver to use the new PPD.

- **Job Accounting**

Use to control printer access and to monitor consumables usage.

## Utilities on the Web (Windows Only)

Here is a list of the utilities provided via a download from the internet, accessed through the Menu Installer on the CD. For more information, click "Tell me more" on the Internet Options screen in the CD installer.

- **PrintSuperVision**

View the real-time status of printers, monitor and report printer usage, manage consumables, check on the status of printers in the same department, the same building, the same country or on the other side of the world.

- **Color Correct Utility**

Helps adjust how RGB colors are printed: office palette tuning, hue/saturation/gamma tuning.

- **Storage Device Manager**

Requires the hard disk drive, optional on some models. Download PCL macros, Postscript forms and bar codes to the printer hard disk drive for use in print jobs.

- **Job Accounting Utility**

Use to control printer access and to monitor consumables usage.

- **Profile Assistant**

Requires the hard disk drive, optional on some models. Store ICC profiles to the [printer's hard disk drive.

- **PS Gamma Adjuster**

Permits adjustment of each of the primary colors that the printer uses in Postscript mode.

## **Installing the Utilities** \_\_\_\_\_

### **Utilities on the CD**

Load the utilities from the Menu Installer located on the CD supplied with your printer.

### **Download Utilities (Windows only)**

Download the utilities from the internet, accessed through the Menu Installer on the CD.

# Specifications

Specifications are subject to change without notice.

ITEM	SPECIFICATION
Dimensions	17-1/8" W x 21" D x 14-1/2" H (435 x 536 x 370 mm) without Duplex unit
Weight	61.5 lbs. (27.6 kg) approx. (without Duplex unit)
Print method	LED exposed light source electronic photographic method
Print speeds	30 pages per minute color 32 pages per minute monochrome
Resolution	600 x 600, 600 x 1200 dpi x 1bit or 600 x 600 dpi x 2 bit
Emulations	PostScript 3 PCL 5c, HP-GL, PCL XL, PCL 6e Epson FX IBM Pro Printer III XL
Auto Features	Auto registration Auto density adjustment Auto consumable counter reset
Memory	256 MB standard, upgradable to 512 MB or 768 MB
Operating platform	<b>Windows</b> 2000/XP/XP Pro x64 bit Edition*/NT4.0 /Server 2003/ Server 2003 x64 bit Edition*, Vista 32 & 64 bit. * x86-64 processors only. Itanium is not supported. <b>Mac</b> OS X (10.2.8 - 10.5 on PPC; 10.4.4 - 10.5 on Intel).
Paper capacity at 20 lb. US Bond (75 g/m <sup>2</sup> )	530 sheets in main tray 530 sheets in optional 2nd or 3rd tray 100 sheets in multi purpose tray (or 50 transparencies or 10 envelopes)
Paper weight	17-47 lb. US Bond (64-176 g/m <sup>2</sup> ) in main tray 17-54 lb. US Bond (64-203 g/m <sup>2</sup> ) in 2nd or 3rd tray 17-58 lb. US Bond (64-220 g/m <sup>2</sup> ) in multi purpose tray

ITEM	SPECIFICATION
Paper output	350 sheets in face down (top) stacker @ 20 lb. US Bond (75 g/m <sup>2</sup> ) 100 sheets in face up (rear) stacker @ 20 lb. US Bond (75 g/m <sup>2</sup> )
Paper feed <sup>a</sup>	Paper tray, manual feed, optional additional paper tray(s)
Media size - any tray	Letter, Legal 13/13.5/14 inch, , Executive, A4, A5, A6, B5.
Media size - MP tray	Letter, Legal 13/13.5/14 inch, , Executive, A4, A5, A6, B5, custom (up to 47.25" [1220 mm] length), com-9 envelope, com-10 envelope, monarc3 x 5" [76 x 127 mm]), Photo (4" x 5"/7" [102 x 127/178 mm]), Banner (11.7" x 47.25" [297 x 1220 mm])
Media type	Plain, Letterhead, Transparency, Bond, card stock, Rough, Labels
Exit capacity, 20-lb/ US Bond (75 g/m <sup>2</sup> )	Face up stacker (top exit): 100 sheets Face down stacker (rear exit): 350 sheets
Print accuracy	Start: ±2 mm Paper skew: ±1 mm/100 mm Image expansion/compression: ±1 mm/100 mm
HDD	Capacity - 40 GB
Interfaces	<p><b>Universal Serial Bus (USB)</b></p> <ul style="list-style-type: none"> <li>&gt; USB specification Version 2.0</li> <li>&gt; Connection: USB type B</li> <li>&gt; Cable: USB specification version 2.0 (shielded)</li> <li>&gt; Transmission mode: High speed (480 Mbps + 0.25% maximum)</li> </ul> <p><b>Network</b></p> <ul style="list-style-type: none"> <li>&gt; 10 Base T, 100 Base T</li> </ul> <p><b>Parallel</b></p> <ul style="list-style-type: none"> <li>&gt; IEEE 1284</li> </ul>
Printer life	600,000 pages or 5 years

ITEM	SPECIFICATION
Duty cycle	100,000 pages per month max. 6,000 pages per month average
Replacement toner life	<b>CMYK:</b> 10,000 pages at 5% coverage
Image drum life	20,000 pages (18,000 at 3 pages per job (letter) 12,000 pages at 1 page per job (letter)
Belt life	60,000 letter pages at 3 pages per job
Fuser life	60,000 letter pages
Power supply	220 to 240 V ac @ 50/60 Hz ± 1 Hz
Power consumption	Operating: 1200 W max.; 530 W average (25°C) Stand-by: 100 W max.; 150 W average (25°C) Power saving: 17 W max.
Operating environment	Operating: 50 to 89.6°F (10 to 32 °C)/20 to 80% RH [optimum 77°F (25 °C) wet, 35.6°F (2 °C) dry] Off: 32 to 109.4°F (0 to 43 °C)/10 to 90% RH [optimum 80°F (26.8 °C) wet, 35.6°F (2 °C) dry]
Print environment	Mono Printing: 30 to 73% RH @ 50°F (10 °C) 30 to 54% RH @ 89.6°F (32 °C) 50 to 89.6°F (10 to 32 °C) @ 30% RH 50 to 80.6°F (10 to 27 °C) @ 80% RH Color Printing: 62.6 to 80.6°F (17 to 27°C) @ 50 to 0% RH
Noise (Sound pressure level)	Operating: approx. 55 dB Standby: 37dB(A)

a. Exit method is limited by paper size, media weight and paper feed.