

OKI

MICROLINE

320/321 TURBO Plus

Parallel and USB interface standard version

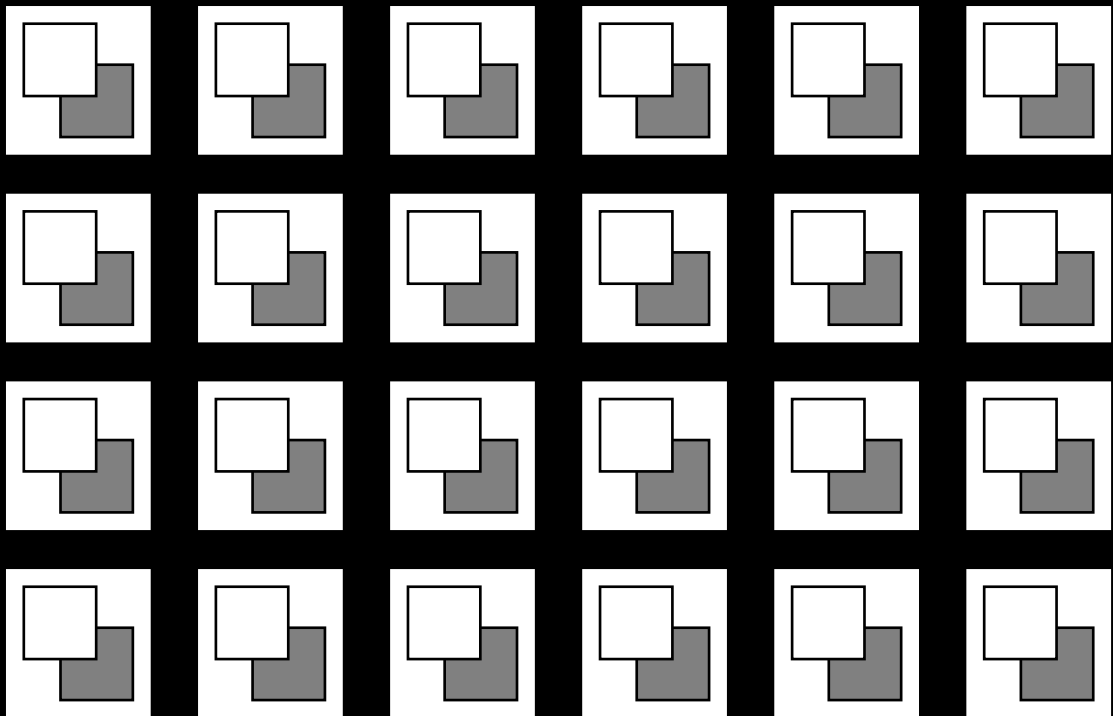

Printer Handbook

Every effort has been made to ensure that the information in this document is complete, accurate and up-to-date. OKI assumes no responsibility for the results of errors beyond its control. OKI also cannot guarantee that changes in software and equipment made by other manufacturers, and referred to in this handbook, will not affect the applicability of the information in this manual. Mention of software products manufactured by other companies does not necessarily constitute endorsement by OKI.

OKI and MICROLINE are registered trademarks of OKI Electric Industry Co., Ltd.. IBM and PC are registered trademarks of International Business Machines Corporation.

Epson is a registered trademark of Seiko Epson Corp. Lotus and 1-2-3 are registered trademarks of Lotus Development Corporation. Microsoft and MS-DOS are registered trademarks and Windows is a trademark of Microsoft Corporation.

WordPerfect is a registered trademark of WordPerfect Corporation.

Important Safety Instructions

Your OKI printer has been carefully designed to give you years of safe, reliable performance. As with all electrical equipment, however, there are a few basic precautions you should take to avoid hurting yourself or damaging the unit:

- Read the setup and operation instructions in this manual carefully. Be sure to save it for future reference.
- Read and follow all warning and instruction labels on the printer itself.
- Unplug the printer before you clean it. Use only a damp cloth; do not use liquid or aerosol cleaners.
- Place your printer on a firm, solid surface. If you put it on something unsteady, it might fall and be damaged; if you place it on a soft surface, such as a rug, sofa, or bed, the vents may be blocked, causing it to overheat.
- To protect your printer from overheating, make sure no openings on the printer are blocked. Don't put the printer on or near a heat source, such as a radiator or heat register. If you put the printer in any kind of enclosure, make sure it is well ventilated.
- Do not put anything into the ventilation slots on the sides of printer, you could get a shock or cause a fire.
- The printhead can get quite hot when it has been printing for a length of time. Do not touch the printhead until it has had a chance to cool off.
- Do not use your printer near water, or spill liquid of any kind into it.
- Be certain that your power source matches the rating listed on the back of the printer. If you're not sure, check with your dealer or with your local power company.
- Your printer has a grounded plug as a safety feature, and it will only fit into a grounded outlet. If you can't plug it in, chances are you have a non-grounded outlet; contact an electrician to have it replaced with a grounded outlet. Do *not* use an adapter to defeat the grounding.
- To avoid damaging the power cord, don't put anything on it or place it where it will be walked on. If the cord becomes damaged or frayed, replace it immediately.

- If you're using an extension cord or power strip with the printer, make sure that the total of the amperes required by all the equipment on the extension is less than the extension's rating. Generally, the total ratings of all equipment plugged into any one power line should not exceed 15 amperes. Don't exceed this unless you know that the power line your equipment is plugged into has a rating above 15 amperes.
- Aside from the routine maintenance described in this handbook, don't try to service the printer yourself; opening the cover may expose you to shocks or other hazards. Don't make any adjustments other than those outlined in the manual – you might cause damage requiring extensive repair work.
- If anything happens that indicates that your printer is not working properly or has been damaged, unplug it immediately and follow the procedures in Chapter 5. These are some of the things to look for:
 - The power cord or plug is frayed or damaged.
 - Liquid has been spilled into the housing, or the printer has been exposed to water.
 - The printer has been dropped or its cabinet has been damaged.
 - The printer doesn't function normally when you're following the operating instructions.
- Do not connect this product to an uninterruptible power supply (UPS).

ontents

Introduction	1
Chapter 1: Installation	3
Unpacking	3
Removing Shipping Retainers	4
Installing Ribbon Cartridge	5
Making Connections	6
Connection with Computer	6
Connection with Power	9
Chapter 2: Loading Paper	11
Loading Single-Sheet Paper	13
Loading Rear-Feed Paper	16
Paper Handling	21
Tear Feature	21
Forms Tear-off Feature	22
Paper Park Feature	22
Switching Paper Paths	23
Chapter 3: Operation	25
Control Panel	25
Print Mode	27
Indicator Lights	27
Buttons	28
Menu Mode	32
Sample Menu	33
Summary of Menu Settings	34
Menu Mode Indicator Lights	37
Menu Mode Buttons	37
Resetting Menu to Factory Defaults	38

Performing Basic Tasks	39
Selecting Print Quality	39
Selecting Character Pitch	40
Testing Your printer	41
Resetting Top of Form	44
Using Bar codes	44
Chapter 4: Working with Software	49
Basic Terminology	49
Printer Commands	49
Emulations	50
Installing the Printer Driver	50
Printing a Test Page	50
Printing from a Computer	51
OKI DIPUS	51
Controlling the Printer Using DIPUS	51
Chapter 5: Problem Solving, Maintenance, & Service	53
Problem Solving	53
Maintenance	56
Replacing the Ribbon Cartridge	56
Clearing Paper Jams	59
Cleaning the Housing	63
Accessories	64
Replacement Parts	66
Appendix A: Specifications	67
Appendix B: Menu Selections	71
Explanation of Menu Items	74
Appendix C: Printer Commands	81
IBM Proprinter Printer Commands	81
Epson FX Printer Commands	85
OKI Microline (ML) Printer Commands	89

Appendix D: ASCII Character Codes 93

Lower ASCII Character Sets 93
Upper ASCII Character Sets 97
Epson International Character Substitutions 101
IBM International Character Substitutions 102
MICROLINE International Character Substitutions 103
Code Page Character Sets 104

Appendix E: Interfacing 109

Pin Assignments for Parallel Interface Signals 109
Universal Serial Bus (USB) 110
Installing the Serial Interface 111
Pin Assignments for Serial Interface Signals 113



Introduction

This Guide is arranged to help you get your new MICROLINE 320 Turbo Plus or 321 Turbo Plus printer set up and running quickly as well as providing you with more detailed information for future reference. Here's how it's organised:

- Chapter 1 (Installation) shows you how to get your printer ready to run and how to connect it to your computer.
- Chapter 2 (Loading Paper) explains how to load paper for any of the two methods of paper feed.
- Chapter 3 (Operation) describes how to control your printer from the front panel. It also explains how to change the defaults, how to test your printer and how to use bar codes.
- Chapter 4 (Working with Software) gives you information on selecting a driver and installing your printer on popular software packages.
- Chapter 5 (Problem Solving/Maintenance/Service) gives helpful hints on how to solve common printer problems and how to maintain your printer in tip-top shape.
- Appendices A through E contain a variety of reference material, including specifications, menu listings, lists of printer programming commands and ASCII characters.

Chapter 1: Installation

This chapter explains how to unpack and install your new printer.

Unpacking

Unpack your printer and make sure you have the following items. If you are missing any of these items, contact your dealer immediately for a replacement.

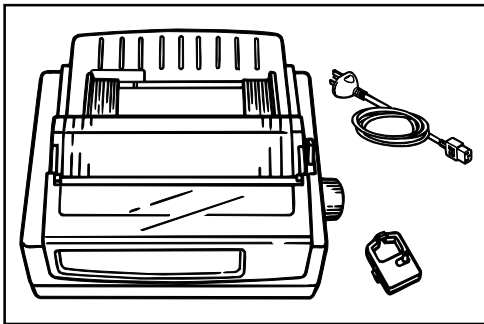

- Printer
- Ribbon cartridge
- AC cord

(It is not included in case of)
some models.

- Printer Handbook & Software on CD-ROM.

 *Interface cable and paper are sold separately.*

Removing Shipping Retainers

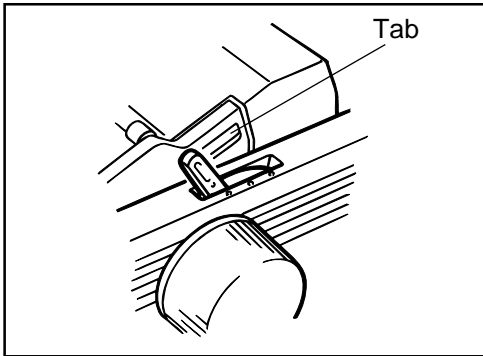

1. Open access cover by grasping tabs at either end and lifting.

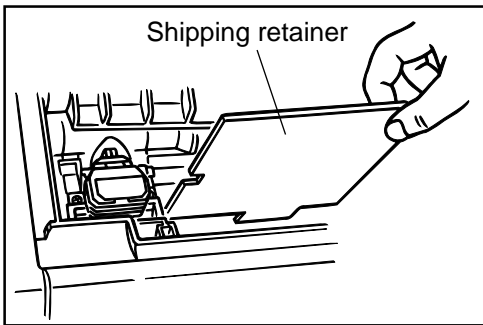

2. Remove printhead shipping retainer (leave cover open for installation of ribbon).

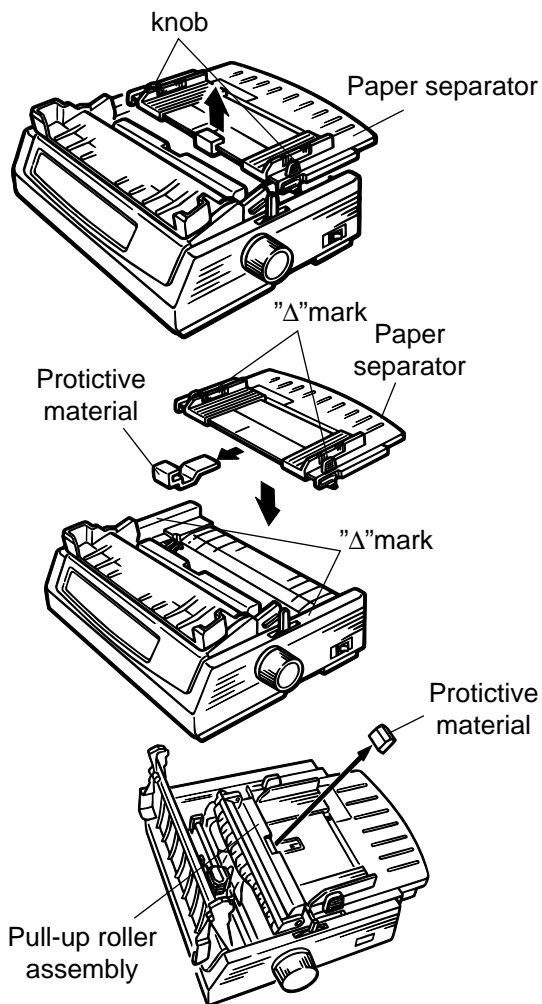

3. Hold the knob and remove the paper separator.
4. Remove the protective material.
5. Set and attach the post to the "Δ" mark of the upper cover and the paper separator.
6. Remove the protective material from the pull-up roller assembly.

Installing Ribbon Cartridge

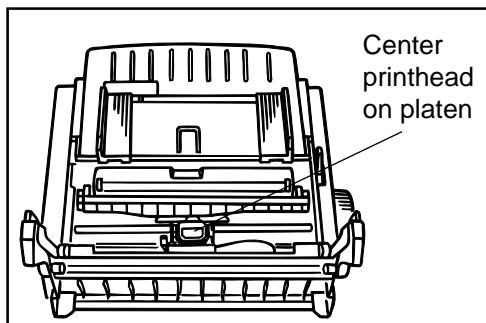

1. With access cover open, grasp print-head and slide it until it is centered on platen.
2. Remove ribbon cartridge from its packaging.

Important! Leave the clear plastic ribbon shield on the cartridge!

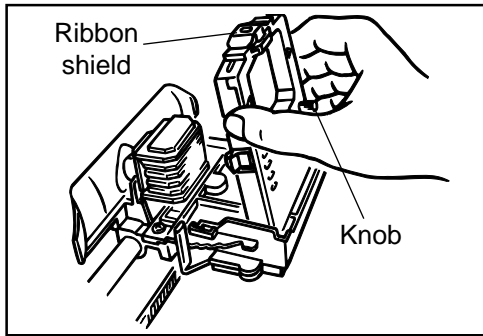

Setting	Headgap lever position	Number of sheets
1	1	1
2	between 1 and 2	2
3	2	3
4	between 2 and 3	4
5	3	envelopes or extra-thick paper

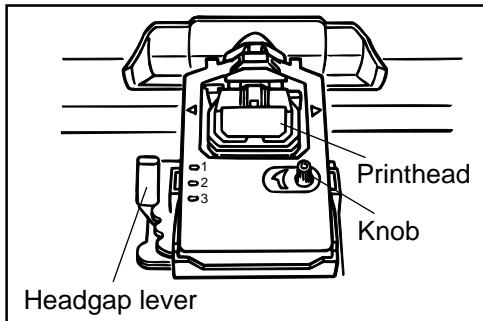

3. Holding ribbon cartridge with knob facing up and ribbon shield facing platen, fit grooves on either side at back end of cartridge over pins on ribbon plate.
4. Lower front of cartridge over printhead until it snaps into place, then turn knob in direction of arrow (clockwise) to take up ribbon slack.
5. The headgap lever by the side of cartridge adjusts for different paper thicknesses. Set it for the number of sheets in the forms you're using from 1 to 4; use setting 5 for envelopes or extra-thick paper. Adjust the setting up or down for the best print quality.

Note: When the setting is set at 2~5, the printer automatically slows down for better print quality with thicker multipart forms.

Important! Be sure to use only ribbons specifically for use with MICROLINE 100', 320 series.

For best results, use genuine OKI ribbons.

Making Connections

Connection with Computer

These instructions are for the standard parallel interface and USB Interface. Instructions for installation/connection of a serial interface are included with the serial interface accessory. For more information on the serial interface accessory, see Chapter 5.



Pin assignments for the parallel, USB and the serial interfaces are listed in appendix E.

• **Connecting the Parallel Interface Cable**

You must supply the cable for connecting your printer to your computer.

1. Make sure both printer and computer are OFF.
2. Locate interface port on back of printer.

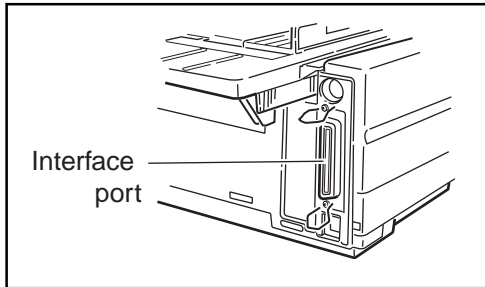

3. Plug parallel interface cable into port and secure it in place with wire loops.

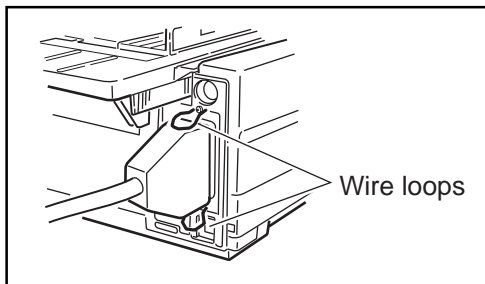

- **Connecting the USB Interface Cable**

You must supply the cable for connecting your printer to your computer.

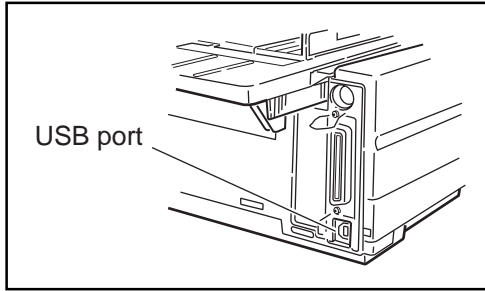

1. Locate interface port on back of printer.

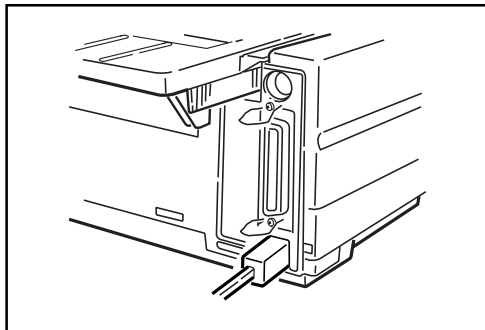

2. Plug USB interface cable into port.

Connection with Power

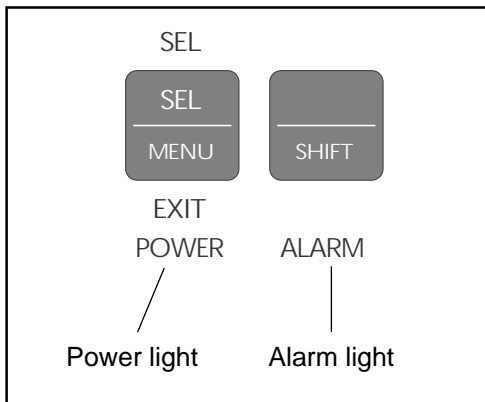
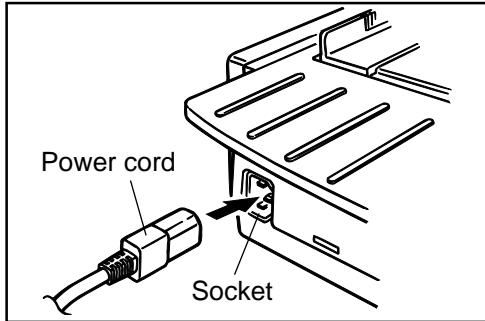

1. Make sure both printer and computer are OFF.
2. Plug power cord into back of printer. Plug other end into grounded outlet.
3. Turn printer on. Printhead will cross back and forth along platen, and POWER light will come on. ALARM light will also come on, but don't be concerned: it's just telling you that there is no paper loaded.

You're now ready to load paper—proceed to Chapter 2.

Chapter 2: Loading Paper

Your printer has provision for single-sheet paper feed from the top and for continuous-form paper feed from the rear. You can also install options: the Cut Sheet Feeder, which holds a stack of 100 sheets for feeding from the top and the Push and/or Pull Tractors for feeding continuous-form labels, heavy card stock or multi-part forms from the bottom. See Chapter 5 for more information on these options.

Top Feed

- Single sheets (basis weight 14 to 24 lbs)
- Single envelopes
 - 24-lb maximum
 - 6.5" to 9.5" wide
- Transparencies (8.5 x 11")

Rear feed (continuous forms only, thickness to 0.014" [0.36 mm])

- Single-part continuous forms
 - 12 to 24 lb.
 - Minimum 3" wide
- Carbonless, multi-part forms
 - Original, plus 3 copies
 - 9 to 11 lb
 - Minimum 3" wide
- Interleaf, multi-part forms (with carbon paper)
 - Original, plus 3 copies
 - 10 to 12 lb paper, with 9 lb carbon
 - Minimum 3" wide

Bottom feed (continuous forms only, thickness to 0.017" [0.44mm])

- Single-part continuous forms
 - 12 to 24 lb
 - Minimum 3" wide
- Carbonless, multi-part forms
 - Original, plus 4 copies
 - 9 to 11 lb
 - Minimum 3" wide
- Interleaf, multi-part forms (with carbon paper)
 - Original, plus 4 copies
 - 10 to 12 lb paper, with 9 lb carbon
 - Minimum 3" wide
- Continuous-feed envelopes
 - 24 lb maximum
 - 6.5" to 9.5" wide (envelope itself)
- Labels
 - minimum 3" wide
 - maximum 10" (ML320 Turbo Plus) or 16" (ML321 Turbo Plus) wide
- Card stock: papers up to 120 lb maximum

Loading Single-Sheet Paper

The single-sheet paper path is best for letterhead stationery, memos, and envelopes. We also recommend it for printing graphs and charts because it provides the most accurate control of the paper.

To load in single sheets of paper:



*If you have any continuous-form paper in the paper path, you must press the **PARK** button on the front panel to remove it from the path before lading single sheets.*

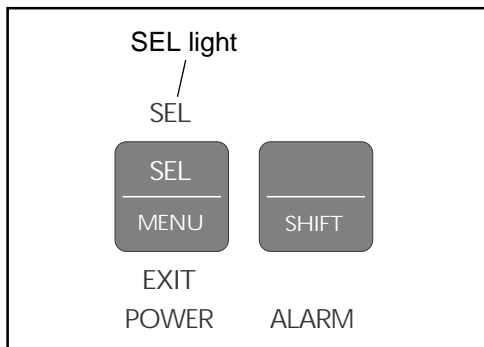

1. Make sure printer is turned ON and deselected (SEL light off – press SEL button to deselect if necessary).



*The **ALARM** light will remain on until paper is loaded.*

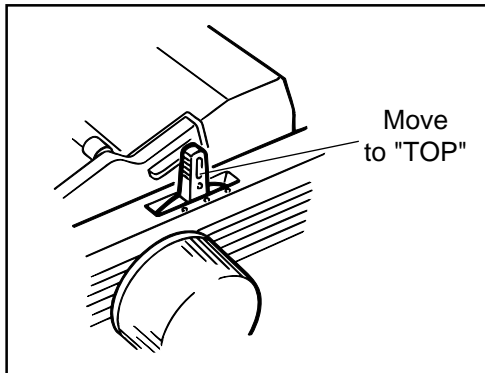

2. Move paper lever to position marked "TOP".

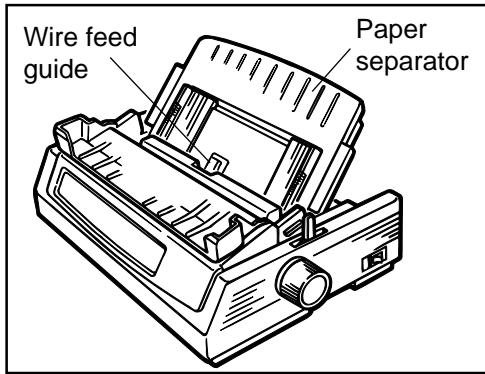

3. Grasp back of paper separator and un-snap it from housing, then swing it up into single-sheet feed position, making sure that wire feed guide is nestled in separator.

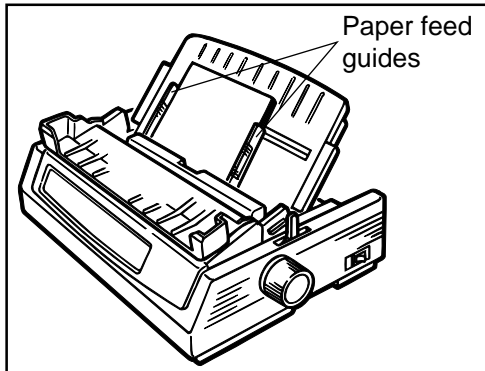

4. Adjust paper feed guides for width of paper and drop sheet of paper into separator. Paper will automatically feed into printer.

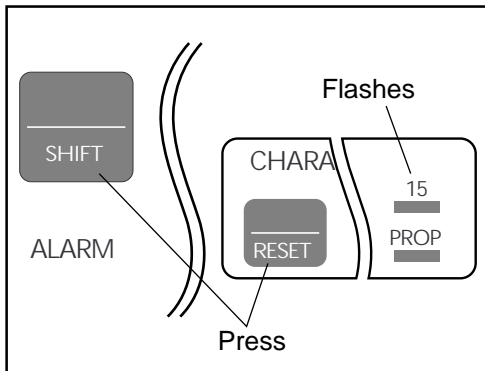

 *If the sheet of paper doesn't feed in properly, the "15" light in the Character Pitch section at the bottom right of the control panel will begin flashing. To correct this, press the SHIFT and RESET buttons simultaneously, then reload the sheet.*

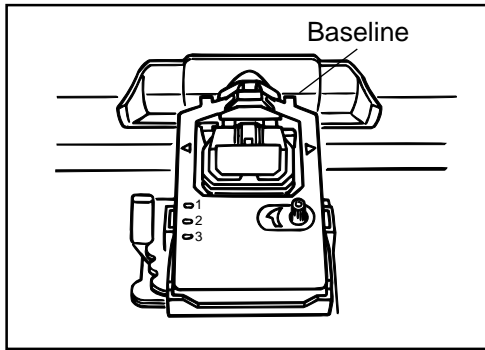

- Baseline for Top of Form (TOF) on paper is indicated by red line on clear plastic paper shield.

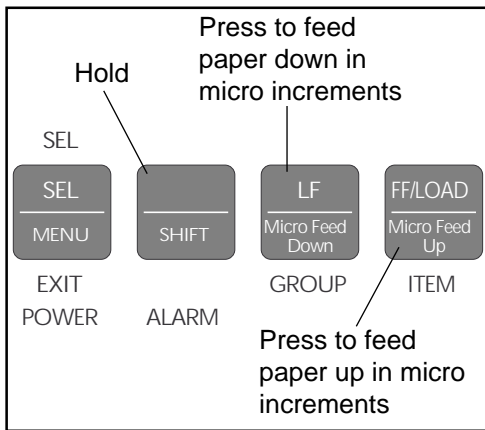

- If desired, change TOF setting using control panel:

☞ to set TOF further down on page, hold SHIFT button while pressing FF/LOAD button: this will advance paper up in micro increments

☞ to move TOF further up on page, hold SHIFT button while pressing LF button: this will advance paper down in micro increments

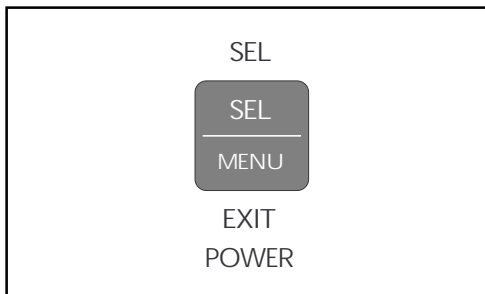

- Press SEL button (SEL light will come on).

Loading Rear-Feed Paper

The rear-feed paper path is recommended for single-thickness, continuous fan-fold paper when printing spreadsheets, long reports, etc. For graphics or charts, it's best to use the single-sheet paper path.

To load continuous-form paper from the rear:

1. If you have paper in paper path, be sure to remove it before installing rear-feed paper. To remove single sheet, press FF/LOAD button. To remove bottom-feed paper, press PARK button.
2. Move paper lever to position marked "REAR".

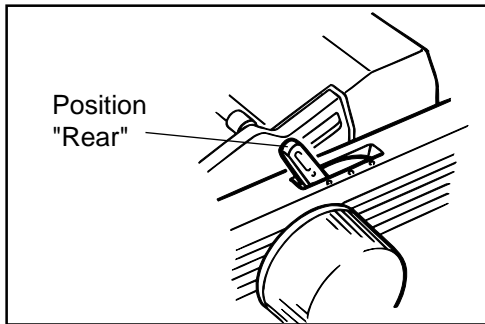

3. Open the access cover, hold up the knob of the paper separator, and remove the paper separator. (Remove the paper separator.)

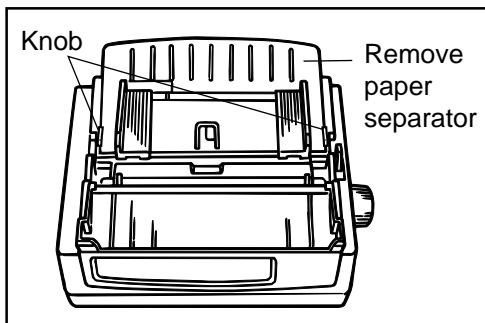

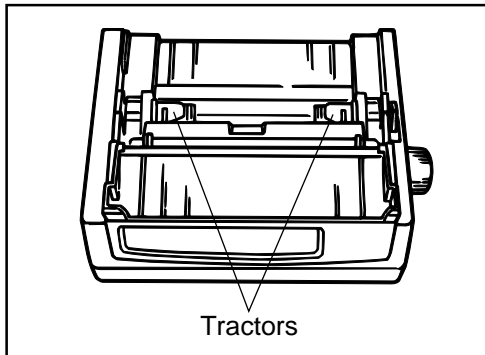

4. Locate tractors.

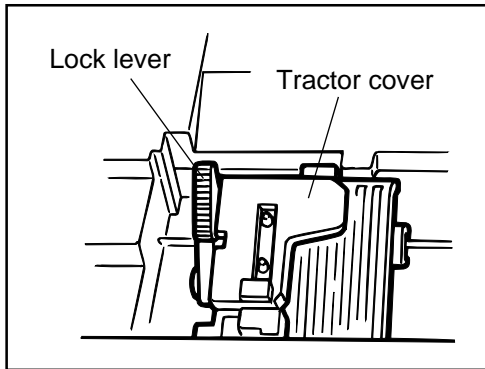

5. Pull up on lock levers to release tractors and swing open tractor covers. Position right-hand tractor for width of paper you're loading.



The movement of the left tractor is limited to ensure that the paper will always contact the paper sensor when loaded.

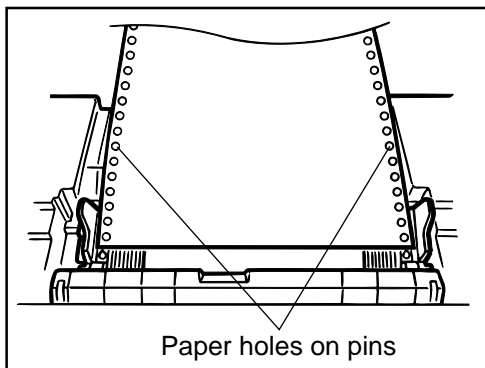

6. Pull paper, and place first two holes on each side over tractor pins. Please note that an equal number of paper holes must be engaged on either tractor in order to ensure proper paper feed.

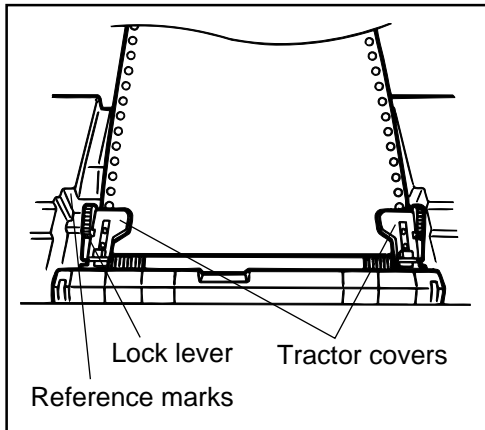

7. Close tractor covers and adjust left tractor to position edge of paper: reference marks on printer indicate left edge position for the two most common paper sizes. When paper is properly aligned, lock left tractor in place by pushing back on lock lever.
8. Adjust right tractor so that paper holes are centered on pins (careful – if paper is stretched too tight or left too loose, it can jam and cause problems), then lock right tractor in place by pushing back on lock lever.

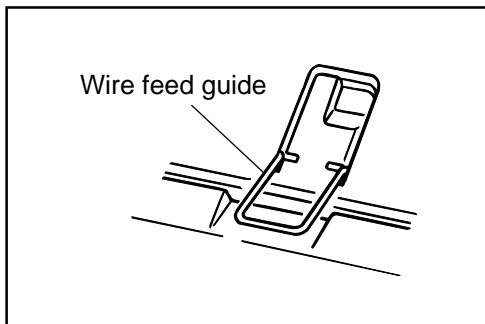

9. Set Paper separator and swing wire feed guide over to rest on pull-up roller assembly to prevent from curling back into printer.

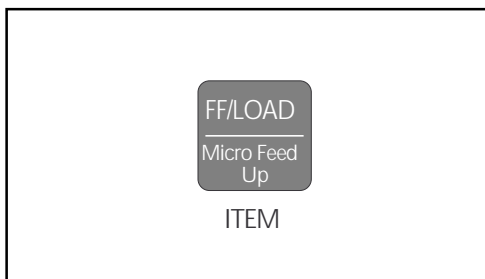

10. Push FF/LOAD button. Paper will automatically feed into printer and ALARM light will go out.

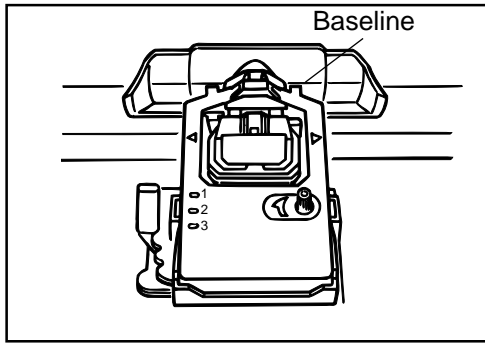

11. Baseline for top of Form (TOF) on paper is indicated by red line on clear plastic paper shield.

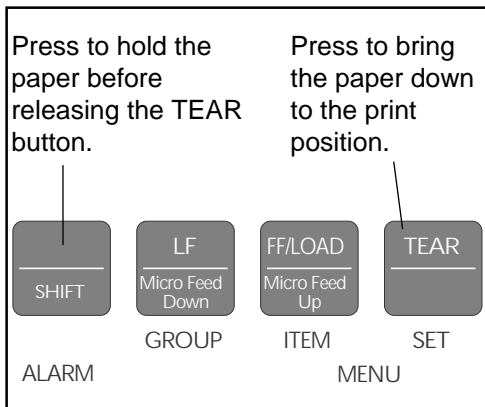

12. If desired, change TOF setting using control panel:

If form tear off is being selected in the printer menu, press the TEAR button to bring the paper down to the print position. Hold down the SHIFT button and release the TEAR button.

☞ to set TOF further down on page, hold SHIFT button while pressing FF/LOAD button: this will advance paper up in micro increments

☞ to move TOF further up on page, hold SHIFT button while pressing LF button: this will advance paper down in micro increments

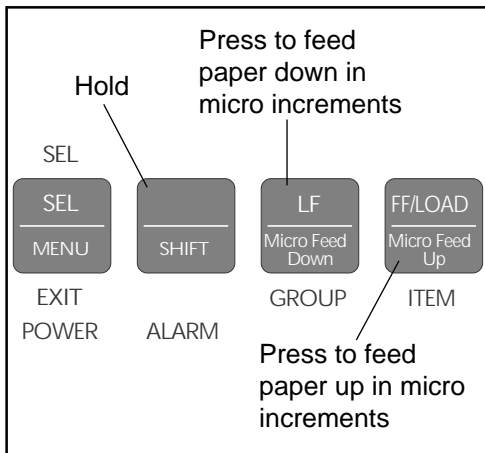

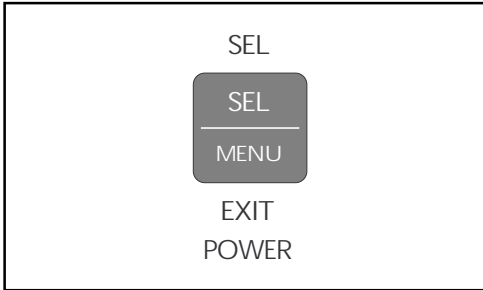

13. Press SEL button (SEL light will come on).

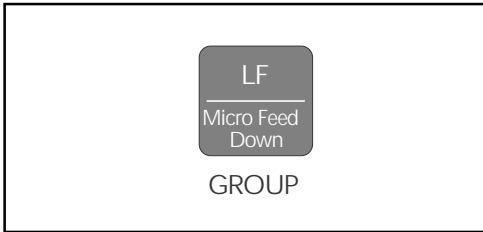

To temporarily change the Top of Form setting for a particular print job, deselect the printer and press the LF button until you reach the TOF position you want to use. The printer will retain this setting until you turn it off.

Paper Handling

Your printer has several handy paper handling features:

- Tear
- Form Tear-off
- Paper Park

Tear Feature

When you're using continuous forms with either the built-in rear-feed tractor or the optional bottom-feed push tractor, you can use this feature to advance the forms up to the tear position so you can easily tear off a printed sheet without wasting paper or readjusting the printer. To do this, simply press the TEAR button on the front panel.

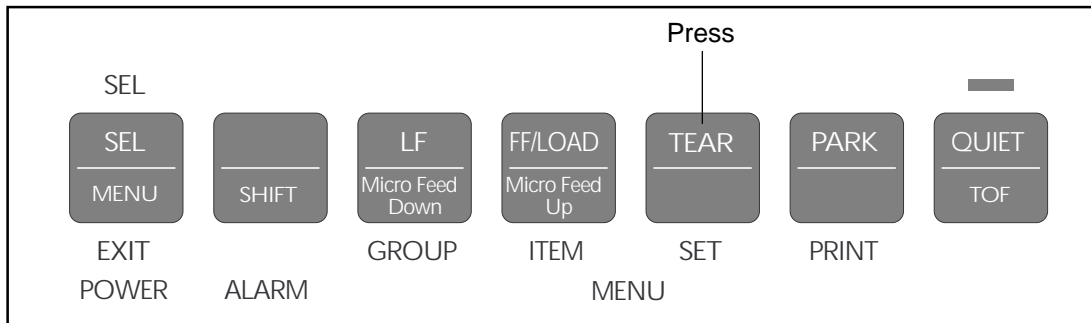

The tear feature can not be used when the optional pull tractor is installed.

Forms Tear-off Feature

Caution! Do not engage Forms Tear-off when printing on labels!

The Forms Tear-off feature can be engaged to automatically move the paper up to the tear position after the selected interval (500 milliseconds, one second, or two seconds). The page will stay in the tear-off position until the printer receives data. It will then move down to the initial printing position.

This feature is normally turned off. To activate it, enter the printer menu (see *Menu Mode* in Chapter3) and choose one of the intervals.



Some programs, such as high resolution graphics packages, pause occasionally while sending data to the printer. If the pause lasts more than the selected interval, the paper will advance to the tear-off position until more data is received. No data will be lost, but this extra paper movement can cause uneven print registration in graphics. If you have this problem, use the menu to deactivate Forms Tear-off.

Paper Park Feature

If you have continuous-form paper loaded and you wish to switch to another paper path, first tear off the printed pages, then simply press the PARK button. The continuous-form paper will immediately retract from the paper path.

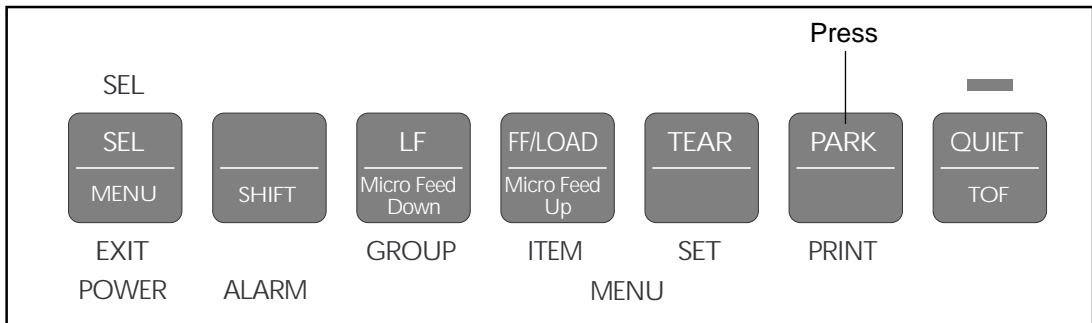

Switching Paper Paths

To switch from continuous-form feed from the rear or bottom (optional push or pull tractor installed) of the printer to single-sheet feed from the top:

1. Tear off printed pages.
2. Press PARK button.
3. Swing wire guide up into paper separator, then pivot separator to upright position.
4. Move paper lever to position marked "TOP".
5. Load single sheet paper into paper separator.

To switch from top feed to continuous-form rear or bottom (optional push or pull tractor installed) feed:

1. Make sure no sheet is in paper path (press FF/LOAD to remove single sheet from path).
2. Lower paper separator to continuous forms position and swing wire guide over onto pull-up roller assembly.
3. Move paper lever to position marked "REAR" or "BOT", as appropriate.
4. Press FF/LOAD button. Continuous-form paper will advance into print position.

Chapter 3: Operation

This chapter explains how to operate your printer. It also provides instructions on how to change the default settings and how to perform basic tasks, including selecting typeface/print quality, selecting character pitch, testing your printer, and resetting Top of Form to the factory default.

Control Panel

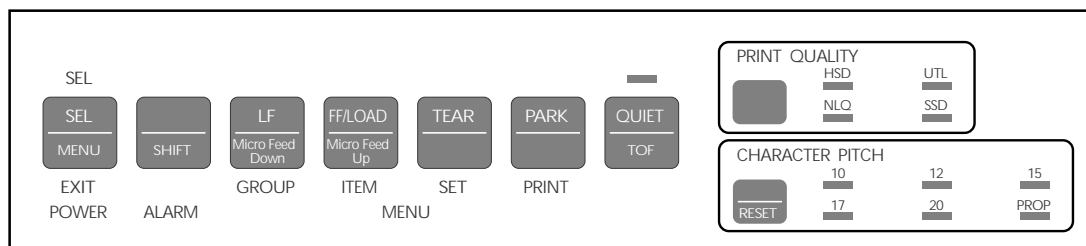

Your printer's front panel lets you control paper feeding, customize your printer's defaults to your particular needs, and select print quality and character pitch.

Here's a breakdown of the controls on the front panel:

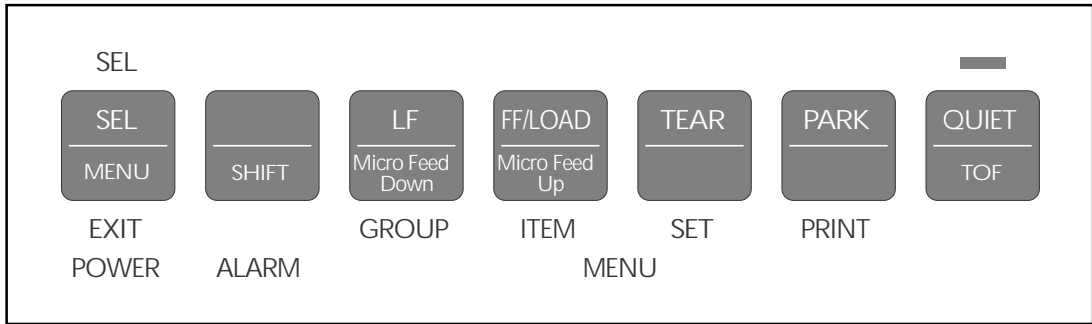

The seven buttons to the left on your control panel are multi-function buttons. In routine printer operation, they are used to manipulate the paper, but you can also use them to enter and make changes in the printer's program menu.

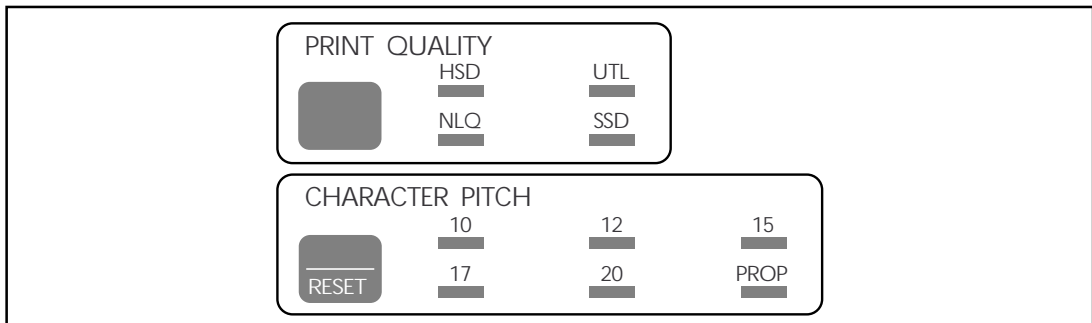

The PRINT QUALITY and CHARACTER PITCH sections at the right on the front panel are used to select the quality and size of the printing. See "Performing Basic Tasks" later in this chapter for information on how to use these buttons.

Important! The print quality and character pitch set by means of the front panel can be overridden by commands sent by the commercial software package from which you're printing a document. If you run into this problem, see Chapter 5 for information on how to correct it.

Print Mode

In its normal operating state, your printer's front panel is in the Print Mode.

Indicator Lights

In the Print Mode, your printer has the following lights to indicate its status:

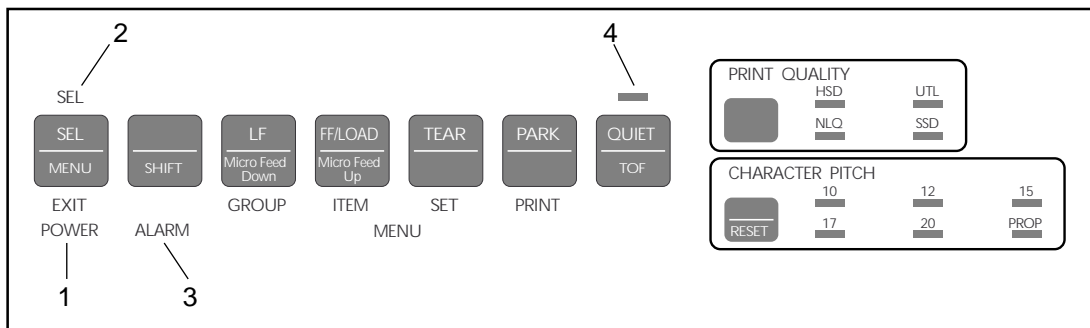

1. **POWER light:** Glows whenever printer is on.
2. **SEL light:** Glows when printer is selected, ready to receive data. Flashes when printer is in print suppress mode. Goes out when printer is deselected (can't receive data).
3. **ALARM light:** Glows when error condition exists, such as out of paper or paper jam. Also glows when paper lever is set to wrong position.

Important! If the ALARM light is blinking, an unrecoverable error condition exists. Try turning the printer off, then on again; if the light is still flashing, contact your service dealer (see Chapter 5 for more information on obtaining service).

4. **QUIET light:** Glows when printer is in QUIET state (printer selected or deselected).

Buttons

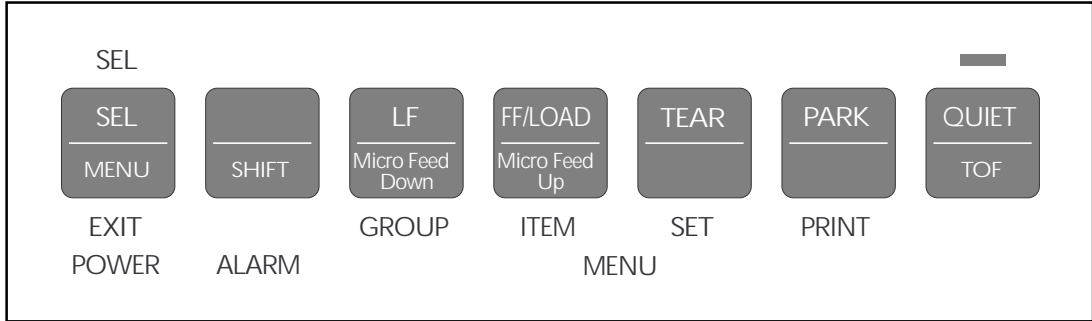

When the printer is selected (SEL light on), only the functions marked at the top of the bank of buttons (LF, FF/LOAD, TEAR, PARK, QUIET) are in effect. When the printer is deselected (SEL light off), the functions marked at the bottom of the buttons (Micro Feed Down, Micro Feed Up, TOF) can be accessed by means of the SHIFT button.

Each button can have several functions, depending on the mode in use (Print Mode or Menu Mode), on whether or not the printer is selected and on whether or not the optional Cut Sheet Feeder (CSF) is installed. Most buttons also have a different function if they are pressed while the printer is being turned on. In addition, different combinations of two buttons can be used to access functions.

The various function available for each button are summarized in the table below.



The PRINT QUALITY and CHARACTER PITCH buttons are discussed under "Performing Basic Tasks," later in this chapter.

Summary of Front Panel Button Functions

Button	Print Mode	Help on Power Up	With CSF Installed	Menu Mode
SEL	Selects/deselects printer. Resets Paper Out of Paper Jam Alarm. Also ends Font Test or Rolling ASCII test .	Activates Menu Mode.	Same as Print Mode	Resets Paper Out Alarm.
SEL + SHIFT	Activates Menu Mode.	Activates Menu Mode.	Same as Print Mode	Exits Menu Mode.
SHIFT	With printer deselected: used with other keys to set and store Top of Form.	N/A	Same as Print Mode	N/A
LF	Advances paper Up one line. Press and hold to advance by repetitive line feeds.	Activates Font Test.	Same as Print Mode	Advances to next Group in Menu.
LF+ SHIFT	With printer deselected, moves Top of Form setting up (paper moves down) on page in micro increments.	Activates Font Test.	Same as Print Mode	Goes back to previous Group in Menu.
FF/LOAD	Feeds in sheet of paper or advances continuous-form paper to print position.	N/A	Inserts or Ejects Page.	Advances to next Item in Menu.
FF/LOAD +SHIFT	With printer deselected, moves Top of Form setting down (paper moves up) on page in micro increments.	N/A	With printer deselected, moves Top of Form setting down on page in micro increments.	Goes back to previous Item in Menu.
TEAR	Moves continuous-feed paper up for tear-off or back down for printing (select/deselect states).	N/A	N/A	Advances to next Value in Menu.

N/A : Not applicable.

Button	Print Mode	Help on Power Up	With CSF Installed	Menu Mode
TEAR+SHIFT	Move the print head to Reverse.	N/A	Move the print head to Reverse.	Goes back to previous Value in Menu.
PARK	Parks continuous-form paper.	N/A	Ejects paper.	Prints list of all Menu settings for current emulation.
PARK+SHIFT	Move the print head to Forward.	N/A	Move the print head to Forward.	Prints current Group Menu Setting.
QUIET	Activates/deactivates QUIET mode.	Activates Rolling ASCII Test.	Activates/deactivates QUIET mode.	N/A
QUIET+SHIFT	Sets Top of Form.	Activates Rolling ASCII Test.	Sets Top of Form.	N/A
PRINT QUALITY	Selects next Print Quality mode.	N/A	Selects next Print Quality mode.	N/A
PRINT QUALITY+SHIFT	Sets/Resets Incremental Print mode.	N/A	Sets/Resets Incremental Print mode.	Prints all Menu settings, regardless of emulation/options engaged.
CHARACTER PITCH	Selects next pitch setting.	N/A	Selects next pitch setting.	N/A
CHARACTER PITCH+SHIFT	With printer deselected, resets printer.	N/A	With printer deselected, resets printer.	N/A
FF/LOAD+TEAR	N/A	Resets Menu and Top of Form to factory default.	N/A	N/A

N/A : Not applicable.

Button	Print Mode	Help on Power Up	With CSF Installed	Menu Mode
SEL+LF	N/A	Resets Menu to factory default.	N/A	N/A
QUIET+ PARK	N/A	Resets Top of Form to factory default.	N/A	N/A
SEL+ FF/LOAD	N/A	Activates hex dump mode.	N/A	N/A

N/A : Not applicable.

Menu Mode

When your printer is in the Menu Mode, you can use the front panel controls to change the defaults for the printer parameters, including emulation, page length, line spacing, typeface, pitch, etc. For example, you might want to change the page length to 14 inches if you're printing on legal-size documents, or to 3 inches if you're printing on labels or small cards.

To place your printer in the Menu Mode, hold the SHIFT button while pressing the SEL button (printer either selected or deselected). The MENU light will come on and, if the printer was selected, the SEL light will go out.

To exit the Menu Mode, hold the SHIFT button and press the SEL button. The MENU light will go out and the SEL light will come on.

Sample Menu

The menu is made up of groups of parameters. Within each group is a list of items and each of those items has several possible settings. Here's a sample Menu printout. The first column lists the groups; the second, items; the third, settings:

Printer Control	Emulation Mode	IBM PPR
Font	Print Mode	Utility
Font	DRAFT Mode	HSD
Font	Pitch	10 CPI
Font	Proportional Spacing	No
Font	Style	Normal
Font	Size	Single
Symbol Sets	Character Set	Set I
Symbol Sets	Language Set	American
Symbol Sets	Zero Character	Slashed
Symbol Sets	Code Page	USA
Rear Feed	Line Spacing	6 LPI
Rear Feed	Form Tear-Off	Off
Rear Feed	Skip Over Perforation	No
Rear Feed	Page Length	11 "
Bottom Feed	Line Spacing	6 LPI
Bottom Feed	Form Tear-Off	Off
Bottom Feed	Skip Over Perforation	No
Bottom Feed	Page Length	11 "
Top Feed	Line Spacing	6 LPI
Top Feed	Bottom Margin	Valid
Top Feed	Page Length	11 2/3 "
Top Feed	Wait Time	1 sec
Top Feed	Page Length Control	by Actual Page Length
Set-Up	Graphics	Uni-directional
Set-Up	Receive Buffer Size	64 K
Set-Up	Paper Out Override	No
Set-Up	Print Registration	0
SET <-- --> SHIFT+SET		
Set-Up	Operator Panel Function	Full Operation
Set-Up	Reset Inhibit	No
Set-Up	Print Suppress Effective	Yes
Set-Up	Auto LF	No
Set-Up	Auto CR	No
Set-Up	SI Select Pitch (10CPI)	17.1 CPI
Set-Up	SI Select Pitch (12CPI)	12 CPI
Set-Up	Time Out Print	Valid
Set-Up	Auto Select	No
Set-Up	Graphics Speed	Low
Set-Up	Centering Position	DEFAULT
Set-Up	ESC SI Pitch	17.1 CPI
Set-Up	Power Save Time	5 min
Set-Up	Time Out FF	Invalid
Parallel I/F	I-Prime	Buffer Print
Parallel I/F	Bi-Direction	Enable
Printer Control	Emulation Mode	IBM PPR

Summary of Menu Settings

The table below details the entries in the printer Menu as it comes from the factory. The defaults are in *bold face italic* type.

Other entries will appear in the Menu depending on what options you have installed and what emulation is engaged.

For a complete listing of all the available Menu selections, along with explanations for each setting, see appendix B.

Group	Item	Setting
Printer Control	Emulation Mode	<i>IBM PPR</i> , Epson FX, ML
Font	Print Mode DRAFT Mode Pitch Proportional Spacing Style Size	<i>Utility</i> , NLQ Courier, NLQ Gothic, DRAFT <i>HSD</i> , SSD <i>10 cpi</i> , 12 cpi, 15 cpi, 17.1 cpi, 20 cpi <i>No</i> , Yes <i>Normal</i> , Italics <i>Single</i> , Double
Symbol Sets	Character Set Language Set Zero Character Code Page	<i>Set I</i> , Set II (EPSON, IBM mode) Standard, Line Graphics, Block Graphics (ML mode) <i>American</i> , French, German, Britishi, Danish I, Swedish, Italian, Spanish I, Japanese, Norwegian, Danish II, Spanish II, Latin American, French Canadian, Dutch, Publisher <i>Slashed</i> , Unslashed <i>USA</i> , Canada French, Multilingual, Portugal, Norway, BRASCII, Abicomp, Multilingual 858, ISO 8859-15
Rear Feed	Line Spacing Form Tear-Off Skip Over Perforation Page Width* Page Length	<i>6 LPI</i> , 8 LPI <i>Off</i> , 500 ms, 1 sec, 2 sec <i>No</i> , Yes <i>13.6"</i> , 8" <i>11"</i> , 11 ² / ₃ ", 12", 14", 17", 3", 3.25", 3.5", 4", 5", 5.5", 6", 7", 8", 8.5"

* ML321 Turbo Plus only

Group	Item	Setting
Bottom Feed	Line Spacing Form Tear-Off Skip Over Perforation Page Width * Page Length	6 LPI , 8 LPI <i>Off</i> , 500 ms, 1 sec, 2 sec <i>No</i> , Yes 13.6" , 8" 11" , 11 2/3", 12", 14", 17", 3", 3.25", 3.5", 4", 5", 5.5", 6", 7", 8", 8.5"
Top Feed	Line Spacing Bottom Margin Page Width * Page Length Wait Time Page Length Control	6 LPI , 8 LPI <i>Valid</i> , Invalid 13.6" , 8" 11", 11 2/3" , 12", 14", 17", 3", 3.25", 3.5", 4", 5", 5.5", 6", 7", 8", 8.5" 1 sec , 2 sec, 500ms <i>by Actual Page Length</i> , by Menu Setting
Set-Up	Graphics 7 or 8 Bit Graphics *1 Receive Buffer Size Paper Out Override Print Registration 7 or 8 Bits Data Word *1 Operator Panel Function Reset Inhibit Print Suppress Effective Auto LF Auto CR *2 Print DEL Code *1 SI Select Pitch (10 CPI) *2 SI Select Pitch (12 CPI) *2 Time Out Print Auto Select Graphics Speed Centering Position CSF Type * ESC SI Pitch *2 Power Save Time Time Out FF	<i>Uni-directional</i> , bi-directional 8, 7 1 Line, 32K, 64K , 128K <i>No</i> , Yes 0 , +1~-+10, -10~-1 8, 7 <i>Full Operation</i> , Limited Operation <i>No</i> , Yes <i>Yes</i> , No <i>No</i> , Yes <i>No</i> , Yes <i>No</i> , Yes <i>No</i> , Yes <i>No</i> , Yes 17.1 CPI , 15 CPI 12 CPI , 20 CPI <i>Valid</i> , Invalid <i>No</i> , Yes <i>Low</i> , High <i>DEFAULT</i> , MODE 1, MODE 2 <i>Wide</i> , Narrow 17.1 CPI , 20 CPI 5 min , 10 min, 15 min, 30 min, 60 min <i>Invalid</i> , 200ms, 500ms, 1sec

* ML321 Turbo Plus only

*1 ML mode Only

*2 IBM mode Only

Group	Item	Setting
Parallel I/F	I-Prime Auto Feed XT *3 Bi-Direction	<i>Buffer Print</i> , Buffer Clear, Invalid <i>Invalid</i> , Valid <i>Enable</i> , Disable

*3 EPSON mode Only

Menu Mode Indicator Lights

In the Menu Mode, the following lights indicate your printer's status:

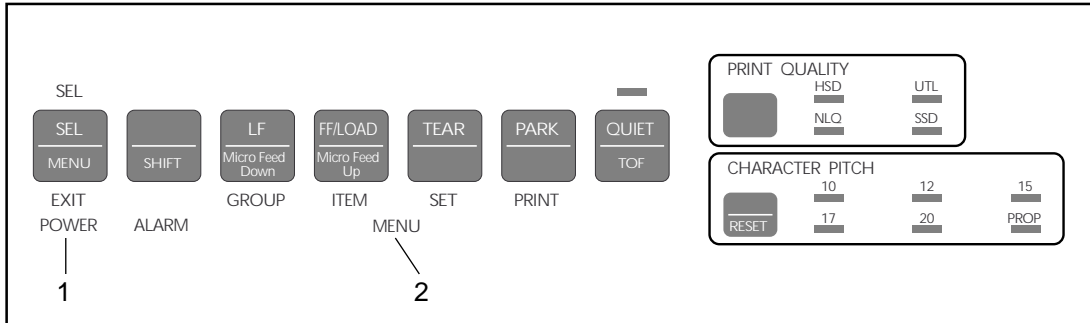

1. **POWER light:** Glows when printer is on.
2. **MENU light:** Glows when printer is in Menu Mode.

Menu Mode Buttons

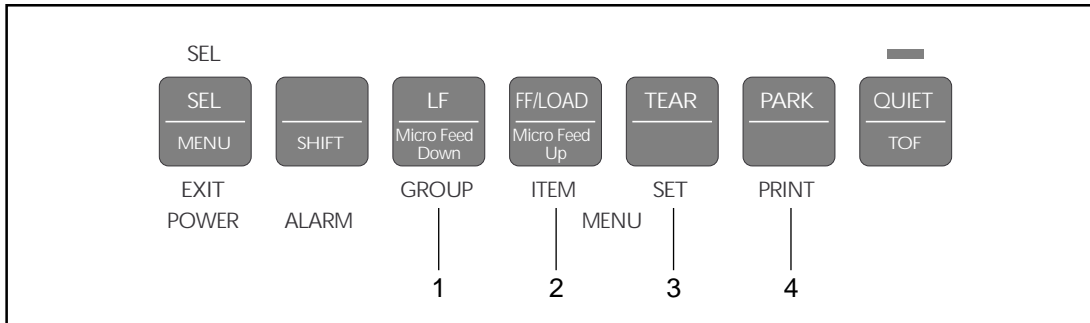

Here is a summary of the buttons active in the Menu Mode:

1. **GROUP button:** Press to scan through groups of listings. Each time you press the GROUP button, a line will print, showing the next group in the Menu. To go back one group, hold the SHIFT button while pressing the GROUP button.
2. **ITEM button:** Press to scan through items for a particular group. Each time you press the ITEM button a line will print, showing the next item within the group. To go back one item, hold the SHIFT button while pressing the ITEM button.
3. **SET button:** Press to change setting for the items. Each time you press the SET button, a line will print across the page showing the next setting for that item. Keep pressing the button until the setting you wish to engage appears. To go back one setting, hold the SHIFT button while pressing the SET button.
4. **PRINT button:** Press to print out listing of current settings for each items, group by group.

Resetting Menu to Factory Defaults

To reset your printer Menu to the factory settings, turn the printer off, then hold the SEL and LF buttons while turning it back on again.

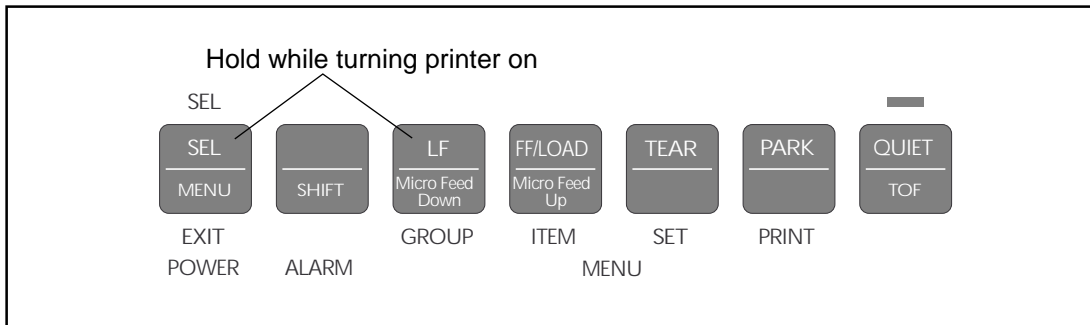

Performing Basic Tasks

Selecting Print Quality

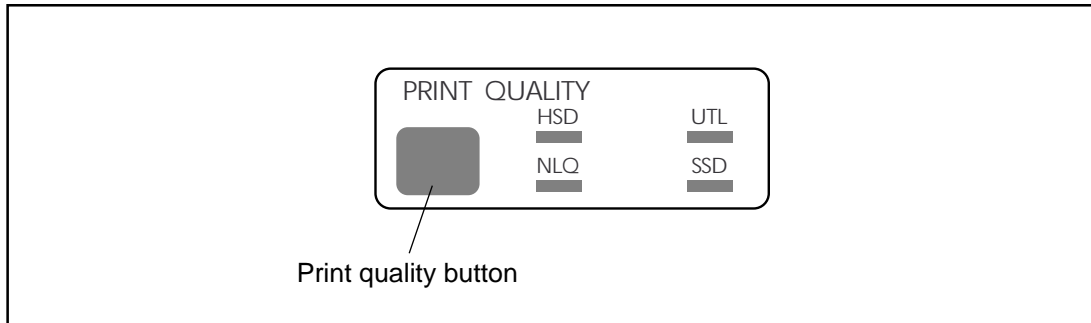

Your printer allows you to select from four print qualities: utility, near letter quality (NLQ), high speed draft (HSD) and super speed draft (SSD). Utility printing, in Gothic, is the default, designed for preparing rough drafts or internal correspondence. NLQ printing, in Courier or Gothic (depending on MENU setting), gives you sharp, crisp characters for correspondence and important final documents that require a polished appearance. HSD and SSD printing, in Gothic, gives the fastest printing, but with the poorest quality.

To select the print quality you want, press the PRINT QUALITY button successively until the light underneath the print quality you wish to engage is lit.



Your printer also prints any of eight different bar codes accessible through printer commands. For more information on bar codes, see the end of this chapter.

Selecting Character Pitch

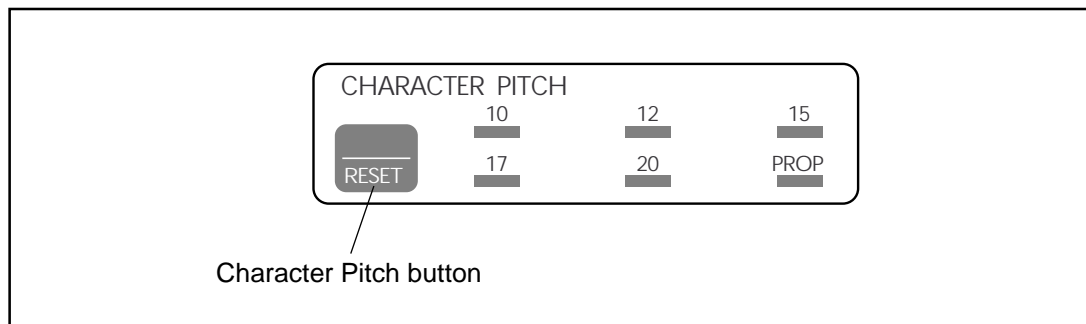

The character pitch determines the width of the individual characters and is measured in characters per inch (cpi). To select the character pitch, press the CHARACTER PITCH button successively until the light underneath the pitch you wish to engage is lit. In the Epson and IBM emulations, the choices are 10 cpi, 12cpi, 15cpi, 17cpi, 20cpi, or Proportional. In the MICROLINE emulation, the choices are 10cpi, 12cpi, 15cpi, 17cpi, or 20 cpi, either non-proportional or proportional: proportional is selected when both the light under the desired cpi and the light under “Prop” are lit.

To reset the pitch to the user default (Menu Setting):

1. Be sure printer is deselected (SEL light out). If not, press SEL button.
2. Hold SHIFT button while pressing CHARACTER PITCH button.



If the SI command is received from your software, the character pitch selected on the control panel will be overridden by the SI command.

The table below summarizes the fonts available from your printer:

Typeface	Spacing
NLQ Courier	10 cpi, 12 cpi, 15 cpi, 17 cpi, 20 cpi, Proportional
NLQ Letter Gothic	10 cpi, 12 cpi, 15 cpi, 17 cpi, 20 cpi, Proportional
Utility (Gothic)	10 cpi, 12 cpi, 15 cpi, 17 cpi, 20 cpi, Proportional
High Speed Draft (Gothic)	10 cpi, 12 cpi, 15 cpi, 17 cpi, 20 cpi
Bar Code	Code 39, UPC A, UPC E, EAN 8, EAN 13, Inter leaved 2 of 5, Code 128, Postnet
Super Speed Draft (Gothic)	12 cpi

Testing Your printer

Your printer has three you can run: the Font Test, the Rolling ASCII Test, and the Hexadecimal Dump Test.

Font Test

The Font Test provides a printout containing samples of available typefaces. Here's a portion of a Font Test printout:

```

ML320Turbo Plus MEI P      F/W 53.00   44709901YR-05
                          LD  01.00

HSD 10CPI
!"###%&'()*+,-./0123456789:;<=>?@ABCDEFGHIJKLMN
OPQRSTUVWXYZ[\]^_`abcdefghijklmnopqrstu
vwxyz{|}~ !"###%&'()*+,-./0123456789:;<=>?@ABCDEFGHIJKLMN
OPQRSTUVWXYZ[\]^_`abcdefghijklmnopqrstu
vwxyz{|}~ !"###%&'()*+,-./0123456789:;<=>?@ABCDEFGHIJKLMN
OPQRSTUVWXYZ[\]^_`abcdefghijklmnopqrstu
vwxyz{|}~

SSD 12CPI
!"###%&'()*+,-./0123456789:;<=>?@ABCDEFGHIJKLMN
OPQRSTUVWXYZ[\]^_`abcdefghijklmnopqrstu
vwxyz{|}~ !"###%&'()*+,-./0123456789:;<=>?@ABCDEFGHIJKLMN
OPQRSTUVWXYZ[\]^_`abcdefghijklmnopqrstu
vwxyz{|}~ !"###%&'()*+,-./0123456789:;<=>?@ABCDEFGHIJKLMN
OPQRSTUVWXYZ[\]^_`abcdefghijklmnopqrstu
vwxyz{|}~ !"###%&'()*+,-./0123456789:;<=>?@ABCDEFGHIJKLMN
OPQRSTUVWXYZ[\]^_`abcdefghijklmnopqrstu
vwxyz{|}~

HSD 17.1CPI
!"###%&'()*+,-./0123456789:;<=>?@ABCDEFGHIJKLMN
OPQRSTUVWXYZ[\]^_`abcdefghijklmnopqrstu
vwxyz{|}~ !"###%&'()*+,-./0123456789:;<=>?@ABCDEFGHIJKLMN
OPQRSTUVWXYZ[\]^_`abcdefghijklmnopqrstu
vwxyz{|}~ !"###%&'()*+,-./0123456789:;<=>?@ABCDEFGHIJKLMN
OPQRSTUVWXYZ[\]^_`abcdefghijklmnopqrstu
vwxyz{|}~ !"###%&'()*+,-./0123456789:;<=>?@ABCDEFGHIJKLMN
OPQRSTUVWXYZ[\]^_`abcdefghijklmnopqrstu
vwxyz{|}~

```

To activate the Rolling ASCII Test:

1. Be sure paper is loaded.

Caution! For wide carriage Model 321 Turbo Plus, be sure you have wide paper loaded!

2. Turn off printer.
3. Hold QUIET button for several seconds while turning printer on. (If printer simply turns on without starting to print, you didn't hold down QUIET button long enough.)

Hexadecimal Dump Test

If you want to test the data your computer is sending to the printer, you can place the printer in the Hexadecimal Dump Mode. When the printer is in the Hex Dump Mode, all data received, including text and printer commands, will be printed in both hexadecimal and ASCII format.



In the ASCII format, all non-printable characters will be represented by a period.

For example, this line of BASIC code:

```
LPRINT CHR$ (27);"0";CHR$ (30);"This is an example of a hexadecimal  
dump."
```

would print like this:

```
1B 30 1B 54 68 69 73 20 69 73 20 61 6E 20 65 78 .0.This is an ex  
61 6D 70 6C 65 20 6F 66 20 61 20 68 65 78 61 64 ample of a hexad  
65 63 69 6D 61 6C 20 64 75 6D 70 2E 0D 0A ecinal dump...
```

To engage the Hexadecimal Dump Mode:

1. Be sure paper is loaded.
2. Turn off printer.
3. Hold SEL and FF/LOAD buttons for several seconds while turning on printer.

The printer will print the line "Hex Data Dump" and be ready to receive data in the Hexadecimal Dump Mode. To run the test, simply send data to the printer while it is in the Hexadecimal Dump Mode.

When you're done, you can exit the Hexadecimal Dump Mode by either pressing the SEL button or by turning the printer off, then on again.

Resetting Top of Form

To reset the Top of Form to the factory default:

1. Turn off printer.
2. Hold down QUIET and PARK buttons while turning printer back on.

Using Bar codes

Your MICROLINE 320/321 Turbo Plus printer incorporates eight different bar codes:

- UPC A
- UPC E
- EAN 8
- EAN 13
- Code 39
- Code 128
- Interleaved 2 of 5
- Postnet

You will find a list of the bar code printer commands for each emulation in appendix C.

Here is a brief explanation of each of the available bar codes, along with a sample printout for each one.

UPC A Bar Code

UPC (Universal Product Code) bar coding is used in the supermarket industry. UPC A coding contains ten digits: the first five digits represent the manufacturer, the second five digits identify the product.



UPC E

UPC E bar coding is a six-digit variation of UPC A, used for labeling small items.



EAN 8

EAN (European Article Numbering) bar coding is a variation of UPC coding. EAN 8 encodes eight digits.



EAN 13

EAN 13 encodes 13 digits and contains the same number of bars as UPC A. The thirteenth digit combined with the twelfth digit provides a code representing a country.



Code 39

Also known as 3 of 9 Code, code 39 is used in non-retail applications. Each character has five bars and four spaces. Code patterns have been developed for 44 different alphabetic, numeric and graphic characters.



Code 128

Code 128 has 106 different characters, each of which can have any one of three different meanings depending on which code set (A, B, or C) is engaged. A special code at the beginning indicates which set is engaged: three shift codes are also available for use within the bar code to indicate a change in the code set engaged, as required.



Interleaved2 of 5

Interleaved2 of 5 bar coding is used mainly in the distribution industry. Two digits are encoded: one in the bars and one in the spaces.



Postnet

Postnet bar coding is used by the U.S. Post Office for sorting mail by automated equipment. It incorporates a coding system using five bars and four spaces for each digit.



Chapter 4: Working with Software

This chapter covers the fundamentals of setting up commercial software packages for use with your printer. Be sure to read your software documentation carefully for more details.

Basic Terminology

Before we start, let's examine a few terms with which you may not be familiar.

Printer Commands



If you're using commercial software with an appropriate printer driver (see "Printer Drivers" below), the printer commands will normally be sent to the printer by your software and you won't even need to think about them.

Printer commands are signals sent by your PC to the printer which guide and control its operation. Printer commands tell the printer what character pitch to use, what font to use, what margins to use, whether to use single or double spacing, when to engage/disengage double width or double height printing, etc.

Printer commands can be sent in decimal, ASCII, or hexadecimal form. The values (decimal/ASCII/hexadecimal) for each type of command depend on which emulation is active (see Appendix C for a listing of printer commands for each emulation).

With only a few exceptions, printer commands begin with the ESC character, decimal 27 (hexadecimal 1B), which serves as signal to the printer that what follows is to be interpreted as a command rather than just a string of characters. Some printer commands expect you supply a numerical value, representing tab stops, line spacing, etc.

Emulations

In order to eliminate hundreds of different sets of printer commands, most printers emulate, or imitate, one of several general printers; i.e., they accept all of that printer's commands and behave as though they were the emulated printer.

Your printer has three emulations:

- IBM Proprinter III (factory default)
- Epson FX
- Oki Microline

Installing the Printer Driver

The driver for your printer is provided on the CD included with the printer. Insert the Drivers CD into your computer and follow the on-screen instructions to install the printer driver for use with your printer.



If the CD does not AutoPlay, click Start > Run > Browse, then browse to your CD-ROM drive, double-click Setup.exe and click OK.

Printing a Test Page

As an example, using Windows XP:

1. Use **Start > Printers and Faxes** to show the Printers and Faxes window.
2. Highlight the driver for your printer.
3. Use **File > Properties** to show the Properties window.
4. On the **General** tab, click the **Print Test Page** button.
5. Ensure that a test page has printed, verifying your printer-computer setup.

Printing from a Computer

When printing to your printer from, for example, a Windows application on your computer, make your printing selections from the driver windows that appear on screen. These driver windows have been designed to be easy to use and intuitive while supplementary on-line help is available by clicking each window Help button.

OKI DIPUS

The **OKI DIPUS** utility allows you remote access to the printer settings using the available applications. You can access DIPUS from **Start > All Programs > Okidata > OKI DIPUS**.

Controlling the Printer Using DIPUS

There are four utilities available within **OKI DIPUS**. Each utility provides access to the printer settings from your computer. Using these utilities you can change the button settings, menu settings, top of form settings and also view the current status of the printer. Any changes made can then be uploaded to the printer and it will be saved to the printer as new settings. These utilities are an alternative to the printer operator panel.

Button setup utility

Using this utility you can activate or deactivate buttons on your printer operator panel. Each button and its function is described in a message view.

Menu setup utility

Using this utility you can view and change your printers' Menu settings.

Status monitor

The Status Monitor utility allows you to view your printers' current status for example, On-line, On-line (power saving) and so on. In the event of a printer error occurring, a warning message is also displayed.

TOF setup utility

Using this utility you can now set the first line of print (TOF) for each page. This utility allows you to treat each print job individually.

For detailed information on each utility and the different settings contained within, refer to the on-line help, by clicking each window Help button.

Chapter 5: Problem Solving, Maintenance, & Service

This chapter provides solutions to some common printer problems and explains the routine maintenance procedures that will help keep your printer in tip-top operating condition. It also tells you how to order parts, consumables and accessories, and provides information on obtaining service for your printer. You will find your printer's warranty at the back of this Printer Handbook.

Problem Solving

What if ...

...nothing happens when I turn on the printer?

The printer may not be plugged in. Check the power cord connection to the outlet and to your printer. If you're using a power strip, make sure it's turned on. Check to be sure that the fuse hasn't blown or that the circuit breaker hasn't tripped.

...the printer doesn't print when the computer sends data?

The printer may be deselected. If the SEL light is out, press the SEL button to select the printer.

The printer cable may not be securely connected. Check the cable to be sure that it is properly connected to both the PC and the printer.

If you have installed the serial I/F board, check to be sure that the board is firmly seated in the printer.

...I'm getting strange symbols, incorrect fonts, etc., when I try to print a document?

The printer driver you have engaged does not agree with the emulation selected for your printer.

To check the emulation selected, first make sure paper is loaded, then press the SEL and SHIFT buttons simultaneously to enter the MENU on your printer. Next, press the GROUP button: this will print the emulation selected.

If the emulation is not the one you want to use, press the SET button to change it to the one you want before exiting the MENU (to exit, press SEL and SHIFT buttons).

If the emulation is correct, check your software documentation on how to select a printer driver, then check to be sure that you have selected one of the drivers listed for that emulation on page 51). The closer the driver is to the top of the list, the more compatible it will be with your printer. If your software doesn't have any of the indicated drivers available, check with the software manufacturer to see if they have added any additional drivers since you purchased your software.

If you have embedded any printer commands in your software, check to be sure that you entered them correctly.

...I've installed a brand new ribbon and the printing is smeared and streaked?

The plastic shield on the ribbon is either loose or missing. The shield must be left on the ribbon when you are installing the cartridge. To remedy this situation, move the printhead to the center of the platen (careful – printhead may be HOT!) and lift off the ribbon cartridge. Check the ribbon shield. If it's loose, secure it in place properly. If it's missing, locate it and reinstall it.

...there are dots missing in my printouts?

The head gap may not be set correctly. Try moving the head gap lever to a lower setting. If that doesn't help, the printhead may be damaged; call for service.

... the Alarm light is on and the Character Pitch 15 light is flashing?

This indicates a paper loading error. To stop the flashing light, press the SEL button. Before trying to load paper in again, check to be sure that you have the paper lever in the correct position (BOT, TOP, REAR) for the path you're using.

Caution! Always turn the printer off before you turn the platen knob!

If the paper lever is in the correct position and you're using rear feed, lift up the paper separator and check to be sure that paper is properly on the tractors and has not jammed up somehow.

If the paper lever is in the correct position and you're using the optional bottom-feed push tractor, check the bottom tractor unit to be sure that paper is properly on the tractors and has not jammed up before entering the printer.

Once the paper is correctly loaded, press and release the SEL button, then hold the SHIFT button and press the RESET (Character Pitch) button.

...I need to load paper, but the Alarm light is *not* on?

If the Alarm light is off, the printer thinks it has paper loaded. To correct this problem, press and release the SEL button, then hold the SHIFT button and press the RESET (Character Pitch) button. The Alarm light will come on and you'll be able to load paper.

...my word processor files don't print the way I have the MENU and front panel set?

Before sending a file to the printer, many word processors send either an "initialization string" or an I-Prime signal to the printer.

The initialization string contains codes that reset the printer to a default set of features: otherwise the printer might accidentally print using features set for a previous job. These codes will override panel or MENU settings. To set your printer to ignore the reset code, enter the printer MENU (hold SHIFT button while pressing SEL/MENU button) and change the Reset Inhibit item (in the Set-Up group) to Yes. Please note that while this will stop the reset code from resetting your printer, other codes in the initialization string may still override the printer MENU and / or front panel settings.

The I-Prime signal is sent over the parallel interface (pin 31) and will automatically override any settings you have made using the front panel buttons. To eliminate this problem, enter the program MENU (hold SHIFT button while pressing SEL/MENU button) and change the I-Prime item (in the Parallel I/F group) to Invalid.

...the Print Quality and Character Pitch buttons on the front panel won't work?

The Operator Panel Function item on the printer MENU can be used to disable these buttons. If the printer is part of a customized system or if it is used by a number of people, the system manager may have used this option to make sure the printer is always set properly.

...static electricity causes the paper to stick?

In cold, dry weather, static charges can build up on continuous-form paper. This can make the paper cling to the paper separator. If you have this problem during high-volume printing jobs, try moving the single sheet paper guides on the separator together so that the paper rests on the guides rather than on the separator itself.

Maintenance

This section explains how to change ribbons, clear paper jams and clean your printer.

Replacing the Ribbon Cartridge

When replacing the ribbon, be sure to use only ribbons specifically for use with MICROLINE 320 /321 Turbo Plus printers. For best results, use genuine OKI ribbons.

1. Turn printer off.
2. Disengage and swing open access cover.

Caution! Be careful not to touch the printhead: it may be *hot*!

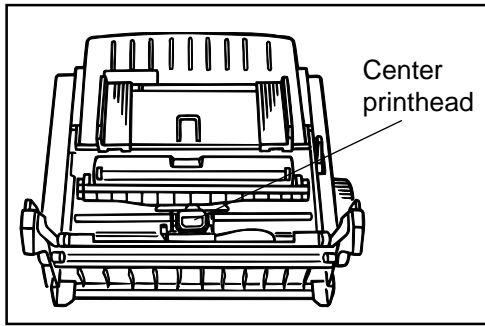

3. Slide ribbon cartridge along until it is centered on platen, being careful not to touch printhead.

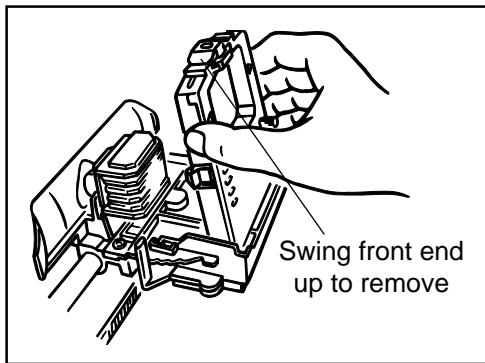

4. Swing front-end of cartridge up off printhead, then lift cartridge out and discard it.

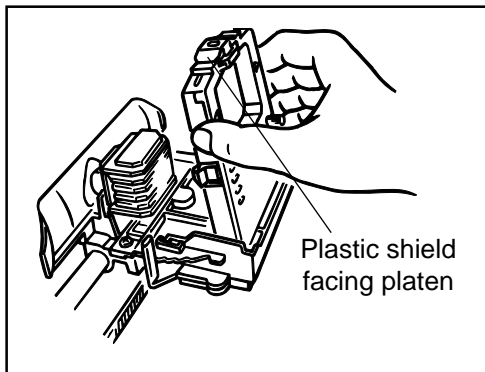

5. Remove new ribbon cartridge from its packaging — **do NOT remove clear plastic ribbon shield!**
6. Hold ribbon cartridge with knob facing up and exposed portion of ribbon facing platen. Place flat end on ribbon plate, fitting grooves over pins on plate.

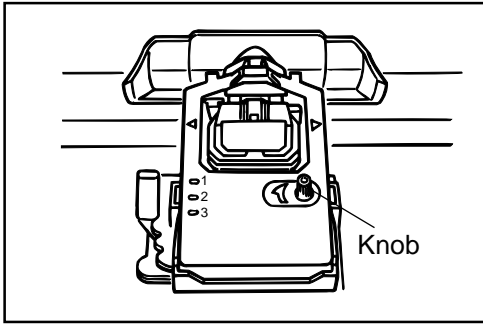

7. Lower front end of cartridge over printhead until it snaps into place. Turn knob in direction of arrow (clock-wise) to take up any slack in ribbon.

Clearing Paper Jams

Caution! Always turn the printer off before you turn the platen knob!

Rear Feed Jams

To clear a rear-feed paper jam:

1. Turn off printer
2. Turn platen knob to back paper out of printer. Remove any ripped pieces of paper.
3. Reload paper, turn printer back on and press FF/LOAD button.

If your paper keeps jamming, the chances are excellent that you have bits of paper stuck in the paper path. To eliminate this problem:

1. Turn off printer.
2. Use platen knob to back paper out of printer.
3. Remove the paper separator.

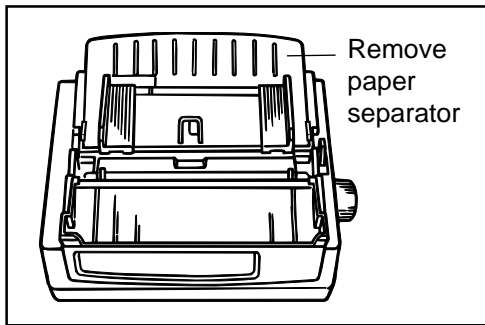

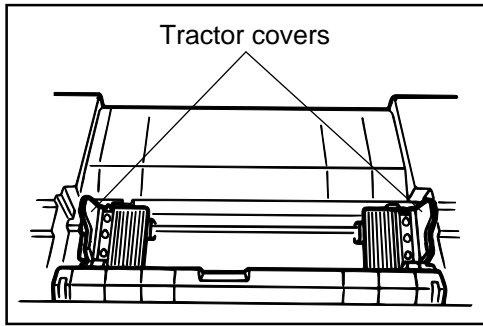

4. Open tractor covers and remove paper from printer.

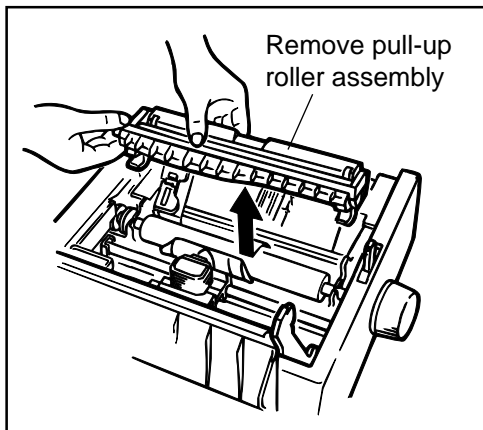

5. Open access cover and lift off pull-up roller assembly.

Note: Never attach or remove the pull-up roller assembly when the paper separator is in the standing state.

6. Fold some single-sheet, continuous-feed paper over three times to produce page four sheets thick.

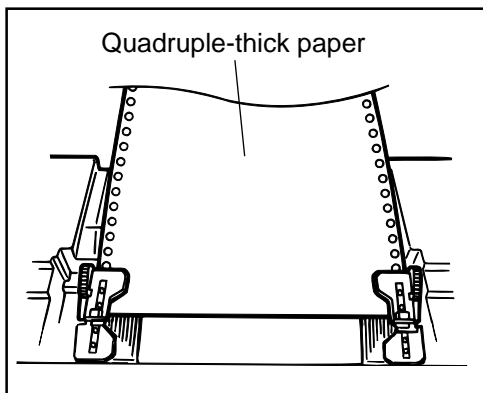

7. Load this quadruple-thick sheet onto tractor pins and close tractor covers.
8. Turn platen knob to draw quadruple-thick paper around platen. This will bring jammed pieces of paper up and out so you can dispose of them.
9. Back quadruple-thick sheet out of printer using platen knob.

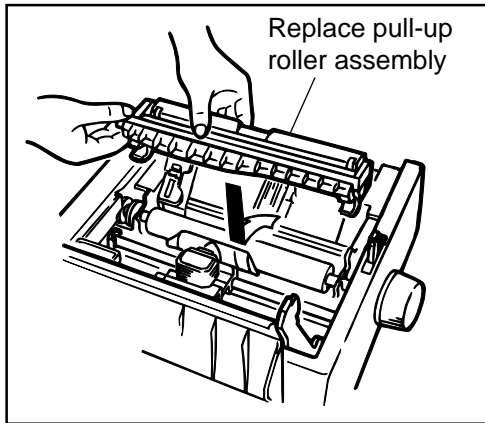

10. Replace pull-up roller assembly.

Note: When installing a pull-up roller assembly, Shift the paper lever in agreement with the "Rear" mark before the installation.

11. Reload regular paper (open tractor covers, place paper on pins, close tractor covers).

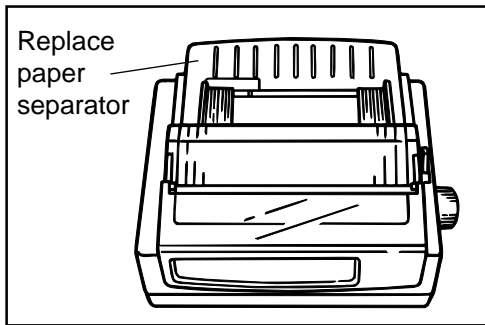

12. Swing access cover and paper separator back into place.

13. Turn printer on and press FF/LOAD button.

Single Sheet Feed Jams

To remove jammed single sheets of paper (top feed):

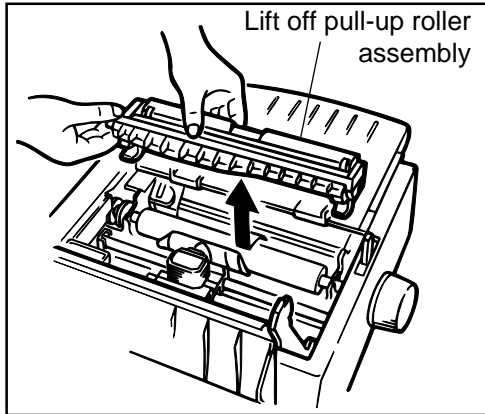

1. Turn printer OFF.
2. Rotate platen knob to back paper out of carriage.
3. If necessary, open access cover and lift off pull-up roller assembly to provide access to remove any ripped pieces from around carriage.

Button Feed Jams

If bottom-feed paper jams:

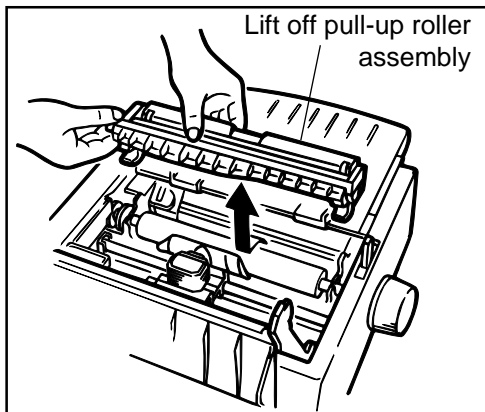

1. Turn off printer and use platen knob to back paper out carefully.
2. Be sure to remove any shreds of paper from printer before reloading paper. (Open access cover and lift off pull-up roller assembly to provide access to carriage area.)

Cleaning the Housing

You should clean the printer every six months (or after about 300 hours of operation). To do this:

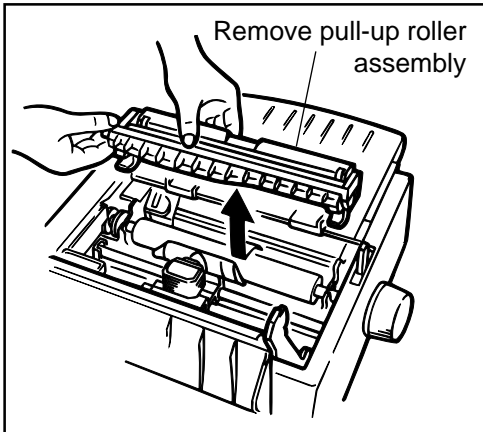

1. Turn printer OFF and remove paper from path.
2. Open access cover and remove pull-up roller assembly.
3. Use clean, dry cloth to dust area around carriage shaft and platen. Be sure to remove any loose particles of paper.

Note: The built-up of dust or paper powder in the printer, which may be occurred by some environmental settings or media used, may cause a malfunction, so execute cleaning according to how the printer is dirty.

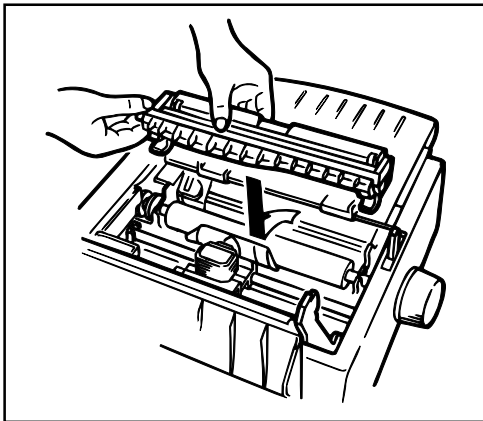

4. Reinstall pull-up roller assembly and close access cover.

Note: When installing a pull-up roller assembly, Shift the paper lever in agreement with the "Rear" mark before the installation.



Never use solvents or strong detergents on the cabinet—they could damage the housing.

Accessories

You can add even more flexibility to your printer by means of the following optional accessories.

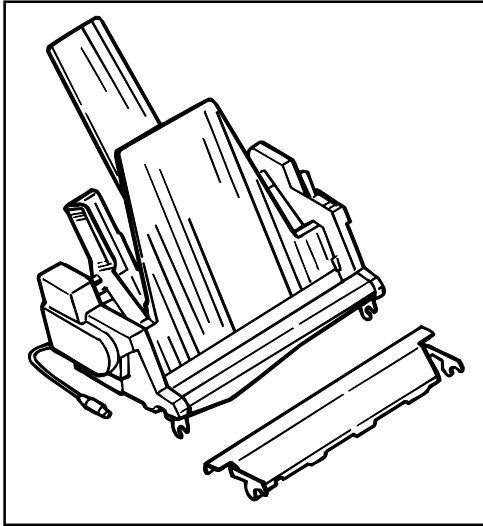

Cut Sheet Feeder, Single-Bin and Dual-Bin

Mounts on the platen to provide continuous single-sheet paper feed. The bin will hold up to 100 sheets of standard, 20-lb paper. With cable for connection to printer.

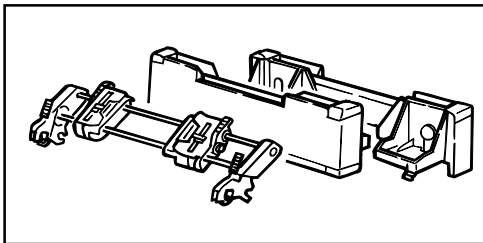

Push Tractor, Bottom-Feed

Converts printer for feeding continuous-form paper from the bottom. Use of bottom feed eliminates the curling which takes place as rear-feed paper moves around the platen. Bottom feed is ideal for card stock, thick multi-part forms, labels which could peel off and jam the unit if fed in from the rear, etc.

Includes tractor, support legs for printer, and metal tear bar.

Pull Tractor, Top-Mount

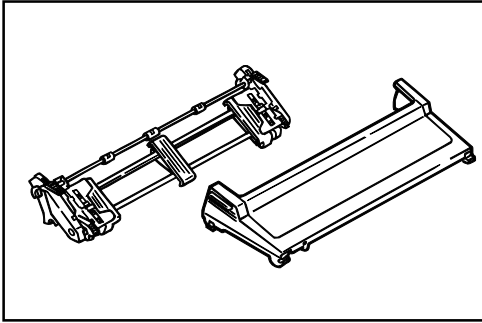

Used for bottom-feed of labels or heavy card stock, or in conjunction with the rear-feed tractor to provide more precise paper control when you're using multi-part forms. Includes cover for installation in place of access cover.

Roll Paper Stand

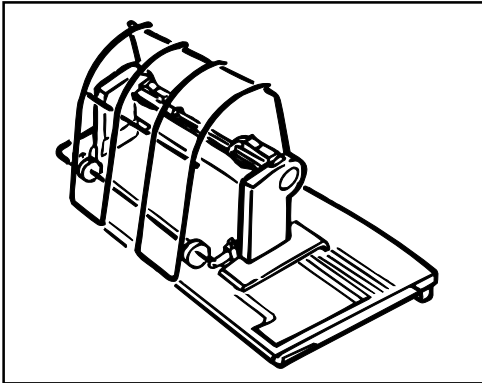

Adapts ML 320 Turbo Plus printer for use with roll-type paper (not supplied). Not usable on ML 321 Turbo Plus.

Includes stand and support. With cable for connection to printer.

Serial Interface

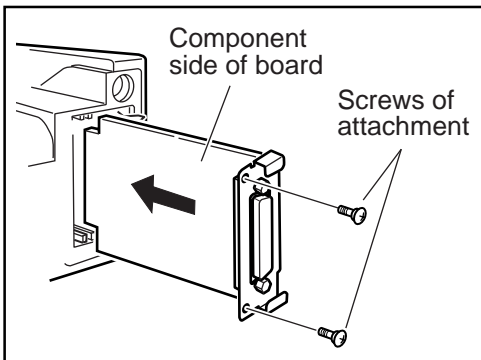

Includes serial interface board and locking piece for installation in printer next to standard parallel interface. Without interface cable.

Note: The use of the locking piece to 320/321 TURBO Plus should be impermissible due to the exclusiveness for other models.

Replacement Parts

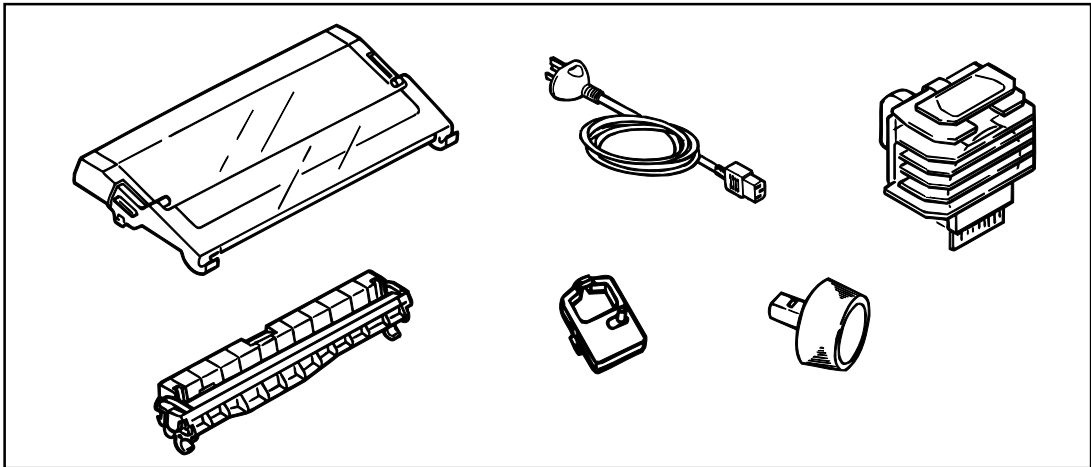

Replacement Part

Access Cover, ML 320 Turbo Plus

Access Cover, ML 321 Turbo Plus

AC Cord

Poll-up Roller Assembly, ML 320 Turbo Plus

Poll-up Roller Assembly, ML 321 Turbo Plus

Platen Knob

Printhead

Ribbon, Black

Appendix A: Specifications

Print Method Impact dot matrix

Printhead 9 pins, 0.34 mm diameter with thermal protection

Print Speed

Mode	Characters per second at 10 Cpi
High Speed Draft (HSD)	387
Utility	290
Near Letter Quality (NLQ)	72.5
Super Speed Draft (SSD)	435

Characters per Line (CPL)

Setting	ML320 Turbo Plus	ML321 Turbo Plus
10 cpi	80 cpl	136 cpl
12 cpi	96 cpl	163 cpl
15 cpi	120 cpl	204 cpl
17.1 cpi	137 cpl	233 cpl
20 cpi	160 cpl	272 cpl

Emulations Epson FX, IBM Proprinter, OKI Microline co-resident

Interface Standard: Centronics parallel, USB
Optional: RS-232C serial

Graphics Resolution:

Epson/IBM Emulations
Single Density: 60 x 216 dpi
Double Density: 120 x 216 dpi
Quadruple Density: 240 x 216 dpi

MICROLINE Emulations
Single Density: 60 x 72 dpi / 72 x 72 dpi
Double Density: 120 x 144 dpi / 144 x 144 dpi
Quadruple Density: 240 x 144 dpi / 288 x 144 dpi

Resident Font

Near Letter Quality	Courier, Gothic
Utility	Gothic
High Speed Draft	Gothic
Super Speed Draft	Gothic
Bar Code:	Code 39, UPC A, UPC E, EAN 8, EAN 13, Interleaved 2 of 5, Code 128, Postnet

Receive Buffer Size

MAX 128K

Reliability

Mean Time Between Failures (MTBR)	10000 hours at 25% duty cycle and 35% Page density
Mean Time to Repair (MTTR)	15 minutes
Printhead life	200 million characters average in 10 cpi utility mode at 25% duty and 35% page density
Ribbon Life (on average, 10 cpi utility)	3 million characters

Paper Specifications

Width

Minimum	3"
Maximum	ML 320 Turbo Plus: 10" ML 321 Turbo Plus: 16"

Weight

12 to 24 lb.

Thickness

Rear feed	0.014"(0.36 mm)
Bottom feed	0.017"(0.44 mm)

Paper type	Feed	Weight	Width range
Cut sheets	Top only	12 to 24 lb.	ML320TurboPlus: 7.2" to 8.5" ML321TurboPlus: 7.2" to 14.3"
Single-part continuous forms	Rear, Bottom	12 to 24 lb.	ML320TurboPlus: 3" to 10" ML321TurboPlus: 3" to 16"
Carbonless, multipart continuous form (orig.+3 copies with rear feed) (orig.+5 copies with bottom feed)	Rear, Bottom	9 to 11 lb.	ML320TurboPlus: 3" to 10" ML321TurboPlus: 3" to 16"
Interleaf, multipart continuous form (orig.+3 copies with rear feed) (orig.+4 copies with bottom feed)	Rear, Bottom	10 to 12 lb paper, 9 lb carbon	ML320TurboPlus: 3" to 10" ML321TurboPlus: 3" to 16"
Labels	Bottom only	N.A.	ML320TurboPlus: 3.25" to 8.5" ML321TurboPlus: 3.25" to 15"
Envelopes, single feed	Top	24 lb. max.	6.5" to 9.5"
Envelopes, continuous feed, non-overlap type	Bottom only	24 lb. max.	6.5" to 9.5"
Card stock	Bottom only	120 lb. max	N.A.
Transparencies	Top only	—	8.5" x 11"

Dimensions (W x D x H)

ML 320 Turbo Plus:	15.7 x 13.6 x 4.6 inch (398 x 345 x 116 mm)
ML 321 Turbo Plus:	21.7 x 13.6 x 4.6 inch (552 x 345 x 116 mm)

Weight

ML 320 Turbo Plus:	12.8 lb (5.8Kg)
ML 321 Turbo Plus:	16.8 lb (7.6Kg)

Environmental Requirements

Operating Temperature:	41 to 95°F (5 to 35°C)
Storage Temperature:	14 to 122°F (-10 to +50°C)
Operating Humidity:	20 to 80% RH
Storage Humidity:	5 to 95% RH

Electrical requirements	220/240 volts ac (-10% / +10%)
	50/60 Hz (±2%)

Specifications subject to change without notice.

Appendix B: Menu Selections

The menu selections for your printer are summarized below. Factory defaults are indicated in **bold face italic**. Explanations for each item follow the table.

 *The table below summarizes all possible menu settings available with your printer. Which of these you will actually see when you are working in the Menu depends on the active emulation and on the options installed.*

Group	Item	Setting
Printer Control	Emulation Mode	IBM PPR , Epson FX, ML
Font	Print Mode DRAFT Mode Pitch Proportional Spacing Style Size	Utility , NLQ Courier, NLQ Gothic, DRAFT HSD , SSD 10 cpi , 12 cpi, 15 cpi, 17.1 cpi, 20 cpi No , Yes Normal , Italics Single , Double
Symbol Sets	Character Set Language Set Zero Character Code Page	Set I , Set II (EPSON, IBM mode) Standard, Line Graphics, Block Graphics (ML mode) American , French, German, Britishi, Danish I, Swedish, Italian, Spanish I, Japanese, Norwegian, Danish II, Spanish II, Latin American, French Canadian, Dutch, Publisher Slashed , Unslashed USA , Canada French, Multilingual, Portugal, Norway, BRASCI, Abicom, Multilingual 858, ISO 8859-15
Rear Feed	Line Spacing Form Tear-Off Skip Over Perforation Page Width* Page Length	6 LPI , 8 LPI Off , 500 ms, 1 sec, 2 sec No , Yes 13.6" , 8" 11" , 11 ² / ₃ ", 12", 14", 17", 3", 3.25", 3.5", 4", 5", 5.5", 6", 7", 8", 8.5"

Group	Item	Setting
Bottom Feed	Line Spacing Form Tear-Off Skip Over Perforation Page Width * Page Length	6 LPI , 8 LPI Off , 500 ms, 1 sec, 2 sec No , Yes 13.6" , 8" 11" , 11 2/3", 12", 14", 17", 3", 3.25", 3.5", 4", 5", 5.5", 6", 7", 8", 8.5"
Top Feed	Line Spacing Form Tear-Off *6 Bottom Margin Page Width * Page Length Wait Time Page Length Control	6 LPI , 8 LPI Off , 500ms, 1 sec, 2 sec Valid , Invalid 13.6" , 8" 11" , 11 2/3" , 12", 14", 17", 3", 3.25", 3.5", 4", 5", 5.5", 6", 7", 8", 8.5" 1 sec , 2 sec, 500ms by Actual Page Length , by Menu Setting
Set-Up	Graphics 7 or 8 Bit Graphics *2 Receive Buffer Size Paper Out Override Print Registration 7 or 8 Bit Data Word *2 Operator Panel Function Reset Inhibit Print Suppress Effective Auto LF Auto CR CSF Bin Select Print DEL Code *2 SI Select Pitch (10 CPI) *1 SI Select Pitch (12 CPI) *1 Time Out Print Auto Select Graphics Speed Centering Position CSF Type * ESC SI Pitch *2 Power Save Time Time Out FF	Uni-directional , bi-directional 8, 7 1 Line, 32K, 64K , 128K No , Yes 0 , +1~+10, -10~-1 8, 7 Full Operation , Limited Operation No , Yes Yes , No No , Yes No , Yes Bin 1 , Bin 2 No , Yes 17.1 CPI , 15 CPI 12 CPI , 20 CPI Valid , Invalid No , Yes Low , High DEFAULT , MODE 1, MODE 2 Wide , Narrow 17.1 CPI , 20 CPI 5 min , 10 min, 15 min, 30 min, 60 min Invalid , 200ms, 500ms, 1sec

Group	Item	Setting
Parallel I/F	I-Prime Auto Feed XT *3 Bi-Direction	Buffer Print , Buffer Clear, Invalid Invalid , Valid Enable , Disable
Serial I/F *5	Parity Serial Data 7/8 Bits Protocol Diagnostic Test Busy Line Baud Rate DSR Signal DTR Signal Busy Time	None , Odd, Even 8 Bits , 7 Bits Ready/Busy , X-On/X-Off No , Yes SSD- , SSD+ , DTR, RTS 19200 bps, 9600 bps , 4800 bps, 2400 bps, 1200 bps, 600bps, 300 bps Valid , Invalid Ready on Power Up , Ready on Select 200 ms , 1 sec.
CSF Bin 1 *4	Line Spacing Bottom Margin Page Width * Page Length	6 LPI , 8 LPI Valid , Invalid 13.6" , 8" 11", 11 2/3" , 12", 14", 17", 3.5", 4", 5", 5.5", 6", 7", 8", 8.5"
CSF Bin 2 *7	Line Spacing Bottom Margin Page Length	6LPI , 8LPI Valid , Invalid 11", 11 2/3" , 12", 14", 17", 3.5", 4", 5", 5.5", 6", 7", 8", 8.5"

* ML 321 Turbo Plus only

*1 Appears only when IBM Proprinter emulation is selected.

*2 Appears only when Microline emulation is selected.

*3 Appears only when Epson FX emulation is selected.

*4 Appears only when optional Cut Sheet Feeder Accessory is installed.

*5 Appears only when optional Serial Interface is installed.

*6 Applicable only when the Roll Paper Stand is installed.

*7 Appears only when optional Dual Bin Cut Sheet Feeder Accessory is installed.

Explanation of Menu Items

These explanations are in alphabetical sequence to make it easier to look them up. Many of the items will appear only with optional equipment installed, as noted below. You will find the items Line Spacing, Form Tear-Off, Skip Over Perforation and Page Length appearing several times in the menu (once for each paper path).

7 or 8 Bit Graphics. Choose 7 (factory default) or 8 bits.

7 or 8 Bit Data word. Choose 8 (factory default) or 7 bits.

Auto CR. IBM mode only. No (factory default) or Yes. Choose Yes to make your printer automatically perform a carriage return when a LF is received at the end of the line.

Auto LF. No (factory default) or Yes. Change to Yes if your printer overprints. Keep this set to No if your software adds a line feed when a carriage is received at the end of a line. If your printout is consistently double spaced, set this item to No.

Auto Select. No (factory default) or Yes. Determines whether or not your printer will automatically be selected after you load in paper. With the factory default (No) engaged, the printer will be deselected so that you can set the Top of Form. If you always use the same Top of Form setting, change this setting to Yes so that you don't have to press the SEL button to select the printer after loading paper.

Auto Feed XT. Epson mode only. Invalid (factory default) or Valid. In the Epson emulation, the XT signal on pin 14 of the parallel interface can control automatic line feed. Some interface cables are wired in such a way that automatic line feed is always in effect: the Auto Feed XT item eliminates this potential problem. The factory setting causes the printer to ignore this signal; if your system uses pin 14 to control automatic line feed, change the setting to Valid.

Baud rate. Appears only if optional Serial Interface is installed. Range from 19,200 to 300 bps: factory setting, 9600 bps. This item sets the transmission rate for the system.

Bi-Direction. Enable (factory default) or Disable. Enables or disables the bi-directional transmission (PnP) in Nibble mode.

Bottom Margin. Valid (factory default) or Invalid. Sets whether or not the printer will ignore the bottom margin setting. Change the setting to Invalid if you want printer to ignore the bottom margin setting. Be careful if you use this feature: it lets the printer continue printing when there's no more paper, which can cause loss of data and may damage the printhead.

Busy Line. Appears only if optional Serial Interface is installed. SSD- (factory default), SSD+, DTR, RTS. If Ready / Busy protocol (factory default) is selected, you can choose which line your system monitors for a busy signal:

SSD -9V, select SSD-

SSD +9V, select SSD+

DTR -9V, select DTR

RTS -9V, select RTS

Busy Time. Appears only if optional Serial Interface is installed. 200 ms (factory default) or 1 sec.

Sets the length of the busy signal when the Ready / Busy protocol (factory default) is engaged.

Centering Position. Choose centering position.

Character Set. Choose IBM Set I (factory default) or IBM Set II. (EPSON, IBM mode)
Choose Standard, Line Graphics. (ML mode)

Code Page. Choose USA (factory default), Canada French, Multilingual, Portugal, Norway BRASCII, Abicomp, Multilingual 858, ISO 8859-15.

CSF Bin Select. Appears only if optional Dual-Bin Cut Sheet Feeder is installed. Choose Bin 1 (factory default) or Bin 2.

CSF Type. Select Wide (default) or Narrow for CSF type.

Diagnostic Test. Appears only if optional Serial Interface is installed. No (factory default) or Yes. Select Yes if you want to perform a diagnostic test of the serial interface.

DRAFT Mode. Choose HSD or SSD for DRAFT font.

The selected font becomes effective when "DRAFT" is selected at the Print Mode selection.

DSR Signal. Applies only when optional Interface is installed. Valid (factory default) or Invalid. Used with Ready / Busy protocol to select the way your system handles the DSR Signal.

DTR Signal. Applies only when optional Serial Interface is installed. Ready on Power Up (factory default) or Ready on Select. Change to Ready on Select if the DTR signal is required when the printer is selected; leave as Ready on Power Up if DTR signal is required when printer is turned on.

Emulation Mode. IBM PPR (factory default), Epson FX, or ML. Selects the Printer command set you want your printer to use: IBM Proprinter III, Epson FX, or OKI Microline.

ESC SI Pitch. Designate the function of ESC SI command to 17 cpi setting (default) or 20 cpi setting.

Form Tear-Off. Off (factory default), 500 ms, 1 sec, or 2 sec. Form Tear-Off advances the paper to the perforation so that you can tear off a sheet of continuous-forms paper. You can turn this feature off, or you can select a time interval for the printer to wait before advancing the paper.

Graphics. Uni-directional (factory default) or bi-directional. Bi-directional graphics print faster than uni-directional graphics, but uni-directional graphics have better print registration. Bi-directional graphics printing can be optimized by adjusting the Print Registration setting in the Menu.

Graphics Speed. Low (factory default) or High. Choose High speed for faster printing when optimum print quality is not an issue.

I-Prime. Buffer Print (factory default), Buffer Clear, or Invalid. Determines how the printer will react to the I-Prime signal from your software. With the factory default engaged, when the printer receives the I-Prime signal, it will print out the contents of the buffer before resetting. Change the setting to Buffer Clear if you wish the printer to dump the contents of its buffer immediately upon receiving the I-Prime signal. Change to Invalid if you want the printer to ignore your software's I-Prime signal. This will permit you to enter settings through the printer's control panel which will not be automatically overridden by the software's settings when the I-Prime signal is sent.

Language Set. American (factory default), French, German, British, Danish I, Swedish, Italian, Spanish I, Japanese, Norwegian, Danish II, Spanish II, Latin American, French Canadian, Dutch, or Publisher. Replaces certain symbols with special characters used in the respective foreign languages.

Line Spacing. 6 lpi (factory default) or 8 lpi. Choose 8 lines per inch for tighter line spacing, to get more lines per page.

Operator Panel Function. Full Operation (factory default) or Limited Operation. Change to Limited Operation to deactivate the PRINT QUANTITY and CHARACTER PITCH buttons on the control panel. Then you can control these features only through your software. This can be useful when several people are using the printer and you don't want its settings changed.

Important! This feature also prevents access to the Menu. To access the Menu, turn the printer off, then hold down the SEL key while turning on the printer.

Page Length. 11" (factory default of Rear and Bottom), 11 ²/₃" (Factory default of Top and CSF), 12", 14", 17", 3", 3.25", 3.5", 4", 5", 5.5", 6", 7", 8", 8.5". Selects the length of the paper you'll be using in your printer. This enables the printer to keep track of the initial printing position on each page (Top of Form).

Page Length Control. Choose page length control system for SASF mode.
by Actual Page Length Control page length by actual physical page length.
by Menu Setting Control page length by logical page length.

Page Width. Appears in Menu for wide-carriage model only. Choose a page width of 13.6" (factory default) or 8".

Paper out Override. No (factory default) or Yes. The paper out detector senses when less than an inch of paper remains in the printer and stops printing at that point. Changing this setting to Yes overrides the detector so you can print closer to the bottom of the page if you're using single sheets. Be careful if you use this feature: it lets the printer continue printing when there's no more paper, which can cause loss of data and may damage the printhead.

Parity. Appears only if optional Serial Interface is installed. None (factory default), Odd, or Even. Selects the type of parity your system uses.

Pitch. 10 cpi (factory default), 12 cpi, 15 cpi, 17.1 cpi, or 20 cpi. Selects the character width measured in characters per inch (cpi).

Power Save Time. Sets the interval the printer waits for more data before it goes into the power save mode.

Print DEL Code. Microline mode only. Choose No (factory default) or Yes.

Print Mode. Utility (factory default) NLQ Courier, NLQ Gothic, DRAFT. Choose one of the NLQ fonts for letter quality printing; choose utility for higher-speed draft printing. Choose DRAFT for HSD or SSD. It prints either of HSD or SSD which is selected at the DRAFT MODE.

Print Registration. 0(factory default), +1~+10, -10~-1. Change the setting as required to obtain the best registration for bi-directional printing.

Print Suppress Effective. Yes (factory default) or No. Enables/disables print suppress command. The factory default enables the print suppress command: the printer will ignore all data it receives after it accepts the print suppress command. Change to No to cause your printer to ignore the print suppress command.

Proportional Spacing. No (factory default) or Yes. Change to Yes to engage proportional spacing of characters.

Protocol. Appears only if optional Serial Interface is installed. Selects the type of protocol your system uses: Ready/Busy (factory default) or X-On/X-Off.

Receive Buffer Size. 64K (factory default), 1 Line, 32K and 128K. Selects the amount of memory devoted to holding received data. Choosing 1 Line will tie up your computer during printing, but if you abort the print job the printer will stop printing much sooner.

Reset Inhibit. No (factory default) or Yes. Change to Yes if you want your printer to ignore the reset command sent by software. This will prevent your software reset command from changing the settings you have made through the front panel controls or through printer commands. If you engage this feature, don't forget that it will also prevent your software from clearing out existing settings when you finish printing one document and switch to another.

Serial Data 7/8 Bits. Appears only if optional Serial Interface is installed. 8 Bits (factory default) or 7 Bits. Change to 7 bits if your system uses a 7-bit data format.

SI Select Pitch (10 CPI). IBM mode only. 17.1 CPI (factory default) or 15 CPI. Sets what pitch (17.1 or 15 characters per inch) will be engaged when the printer control panel is set for 10 cpi and the SI command is received.

SI Select Pitch (12 CPI). IBM mode only. 20 CPI or 12 CPI(factory default). Sets what pitch (20 or 12 characters per inch) will be engaged when the printer control panel is set for 12 cpi and the SI command is received.

Size. Choose Single (factory default) or Double width and height printing.

Skip Over Perforation. No (factory default) or Yes. Change to Yes if you want the printer to advance automatically to the next page when it comes within one inch of the bottom of the page. If your software has its own page formatting controls, keep this item set to No to avoid interface.

Style. Choose Normal (factory default) or Italics.

Time Out FF. Sets Time Out FF Mode On/Off and Delay Time. If Delay Time is selected, FF is executed after the selected time passes after printing ends.

Time Out Print. Valid (factory default) or Invalid. When printing, if the printer doesn't receive any data, a line feed, or a form feed signal for awhile, it will automatically dump out what's in the print buffer. If your software spends a long time prossing between feeding portions of data to the printer, you should change the setting to Invalid to keep your printer from inadvertently dumping the received data while it's waiting for more.

Wait Time. 500 ms, 1 sec (factory default), or 2 sec. Sets the amount of the printer will wait for more data before jumping from the print position up to the form tear off position.

Zero Character. Slashed (factory default) or Unslashed. The factory default will cause a slash to appear in zeros to distinguish them from the capital letter O. To disengage the slashed zero, change this to Unslashed.

Appendix C: Printer Commands

This appendix contains a listing of the printer commands for the IBM proprinter, Epson FX, and OKI MICROLINE emulations, grouped by function.

IBM Proprinter Printer Commands

IBM Function	ASCII Code	Decimal Code	Hexadecimal Code
Bar Code Commands			
Select Bar Code Type and Size	ESC DLE A m n ₁ ... n ₈	27 16 65 m n ₁ ... n ₈	1B 10 41 m n ₁ ... n ₈
Print Bar Code Data	ESC DLE B m n [data]	27 16 66 m n [data]	1B 10 42 m n [data]
Print Postnet Bar Code Data	ESC DLE C n [data]	27 16 67 n [data]	1B 10 43 n [data]
Character Sets			
Select IBM Character Set I	ESC 7	27 55	1B 37
Select IBM Character Set II	ESC 6	27 54	1B 36
Print from IBM Character Set III	ESC \ L _n H _n	27 92 L _n H _n	1B 5C L _n H _n
Print One Character from IBM Character Set III	ESC ^ n	27 94 n	1B 5E n
Select International Character Set *	ESC ! n	27 33 n	1B 21 n
Select Code Page	ESC [TL _n H _n 0 0 H _{cp} L _{cp} 0	27 91 84 L _n H _n 0 0 H _{cp} L _{cp} 0	1B 5B 54 L _n H _n 0 0 H _{cp} L _{cp} 0
Character Size/Spacing			
Select 10 cpi Pitch	DC2	18	12
Select 12 cpi Pitch	ESC :	27 58	1B 3A
Select 15 cpi Pitch *	ESC g	27 103	1B 67
Select 20 cpi Pitch *	ESC SI	27 15	1B 0F
Set Compressed Pitch	SI	15	0F
Superscript Printing On	ESC S 1	27 83 1	1B 53 01
Subscript Printing On	ESC S 0	27 83 0	1B 53 00
Super script/Subscript Printing Off	ESC T	27 84	1B 54

IBM Function	ASCII Code	Decimal Code	Hexadecimal Code
Character Size/Spacing (cont.)			
Start Double Width Printing Line by Line	SO	14	0E
End Double Width Printing Line by Line	DC4	20	14
Double Width Printing On	ESC W 1	27 87 1	1B 57 1
Double Width Printing Off	ESC W 0	27 87 0	1B 57 00
Double Width and/or Height Printing On	ESC [@ L _n H _n m ₁ ... m _k	27 91 64 L _n H _n m ₁ ... m _k	1B 5B 40 L _n H _n m ₁ ... m _k
Proportional Spacing On	ESC P1	27 80 1	1B 50 01
Proportional Spacing Off	ESC P0	27 80 0	1B 50 00
Set Intercharacter Spacing *	ESC Vn	27 86 n	1B 56 n
Character Style			
HSD Print Mode On	ESC # 0	27 35 48	1B 23 30
Select Font	ESC I n	27 73 n	1B 49 n
Italics On	ESC % G	27 37 71	1B 25 47
Italics Off	ESC % H	27 37 72	1B 25 48
Emphasized Printing On	ESC E	27 69	1B 45
Emphasized Printing Off	ESC F	27 70	1B 46
Enhanced Printing On	ESC G	27 71	1B 47
Enhanced Printing Off	ESC H	27 72	1B 48
Underline On	ESC - 1	27 45 1	1B 2D 01
Underline Off	ESC - 0	27 45 0	1B 2D 00
Overscore On	ESC — 1	27 95 1	1B 5F 01
Overscore Off	ESC — 0	27 95 0	1B 5F 00
Select font by Pitch and Point	ESC DEL F P _{n0} P _n L _p H _p	27 16 70 P _{n0} P _n L _p H _p	1B 10 46 P _{n0} P _n L _p H _p
Custom Characters			
Down Line Load Characters	ESC = c ₁ c ₂ m n a ₁ a ₂ d ₁ ... d _k	27 61 c ₁ c ₂ m n a ₁ a ₂ d ₁ ... d _k	1B 3D c ₁ c ₂ m n a ₁ a ₂ d ₁ ... d _k
Copy ROM Character Set to RAM Character Set *	ESC \$	27 36	1B 24
Cut-Sheet Feeder Control			
Insert/Eject Paper *	ESC EM n	27 25 n	1B 19 n

IBM Function	ASCII Code	Decimal Code	Hexadecimal Code
Graphics			
Single Density Graphics	ESC K L _n H _n [data]	27 75 L _n H _n [data]	1B 4B L _n H _n [data]
Double Density Graphics	ESC L L _n H _n [data]	27 76 L _n H _n [data]	1B 4C L _n H _n [data]
Double Speed/Double Density Graphics	ESC Y L _n H _n [data]	27 89 L _n H _n [data]	1B 59 L _n H _n [data]
Quadruple Density Graphics	ESC Z L _n H _n [data]	27 90 L _n H _n [data]	1B 5A L _n H _n [data]
Horizontal Control			
Backspace	BS	8	08
Carriage Return	CR	13	0D
Margin Setting, Left & Right	ESC X n m	27 88 n m	1B 58 n m
Horizontal Tab	HT	9	09
Set Horizontal Tab	ESC D n ₁ n ₂ ... n _k 0	27 68 n ₁ n ₂ ... n _k 0	1B 44 n ₁ n ₂ ... n _k 0
Clear Horizontal Tab Settings	ESC D 0 0	27 68 0 0	1B 44 0 0
Set 4-column Tabulation *	ESC % B n ₁ n ₂ n ₃ n ₄	27 37 66 n ₁ n ₂ n ₃ n ₄	1B 25 42 n ₁ n ₂ n ₃ n ₄
Set Print Position *	ESC DLE @ P _n A ₁ A ₂ P ₁ P ₂ P ₃ P ₄	27 16 64 P _n A ₁ A ₂ P ₁ P ₂ P ₃ P ₄	1B 10 40 P _n A ₁ A ₂ P ₁ P ₂ P ₃ P ₄
Set Relative Dot Position *	ESC L _n H _n	27 124 L _n H _n	1B 7C L _n H _n
Uni-directional Print On	ESC U 1	27 85 1	1B 55 1
Uni-directional Print Off	ESC U 0	27 85 0	1B 55 00
Vertical Control			
Page Length, Set in n Inches	ESC C 0 n	27 67 0 n	1B 43 00 n
Page Length, Set in Lines	ESC C n	27 67 n	1B 43 n
Skip Over Perforation On	ESC N n	27 78 n	1B 4E n
Skip Over Perforation Off	ESC O	27 79	1B 4F
Set Top of Form at Current Position	ESC 4	27 52	1B 34
Form Feed	FF	12	0C
Line Feed	LF	10	0A
Perform ⁿ / ₂₁₆ " Line Feed	ESC J n	27 74 n	1B 4A n
Perform ⁿ / ₁₄₄ " Line Feed	ESC % 5 n	27 37 53 n	1B 25 35 n
Auto Line Feed On	ESC 5 1	27 53 1	1B 35 01
Auto Line Feed Off	ESC 5 0	27 53 0	1B 35 00
Reverse Line Feed	ESC]	27 93	1B 5D
Set Line Spacing to ⁷ / ₇₂ "	ESC 1	27 49	1B 31
Set Line Spacing to ¹ / ₈ "	ESC 0	27 48	1B 30

IBM Function	ASCII Code	Decimal Code	Hexadecimal Code
Vertical Control (cont.)			
Set Line Spacing to $n/216$ "	ESC 3 n	27 51 n	1B 33 n
Set Line Spacing to $7/144$ "*	ESC % 9 n	27 35 57 n	1B 25 39 n
Set Line Spacing to $n/72$ "	ESC A n	27 65 n	1B 41 n
Line feed compound command	ESC DLE H Pno A1 A2 P1 P2 P3	27 16 72 Pno A1 A2 P1 P2 P3	1B 10 48 Pno A1 A2 P1 P2 P3
Perform Line Feed Set by	ESC 2	27 50	1B 32
ESC A n Command			
Vertical Tab	VT	11	0B
Set Vertical Tab	ESC B $n_1 n_2 \dots n_k 0$	27 66 $n_1 n_2 \dots n_k 0$	1B 42 $n_1 n_2 \dots n_k 0$
Reset Vertical Tab to Defaults	ESC R	27 82	1B 52
Miscellaneous			
Cancel	CAN	24	18
Change Emulation *	ESC { n	27 123 n	1B 7B n
Paper-Out Sensor On	ESC 8	27 56	1B 38
Paper-Out Sensor Off	ESC 9	27 57	1B 39
Print Suppress Mode On, ML 320 Turbo Plus	ESC Q STX	27 81 2	1B 51 02
Print Suppress Mode On, ML 321 Turbo Plus	ESC Q STX	27 81 22	1B 51 16
Print Suppress Mode Off (either Model)	DC1	17	11
Set Initial Conditions	ESC [K L _n H _n Init Id a ₁ a ₂	27 91 75 L _n H _n Init Id a ₁ a ₂	1B 5B 4B L _n H _n Init Id a ₁ a ₂
Incremental print mode On, Off	ESC i n	27 105 n	1B 69 n
Software I-Prime *	ESC } 0	27 125 0	1B 7D 00
Stop Printing	ESC j	27 106	

* OKI-Unique command

Epson FX Printer Commands

Epson Function	ASCII Code	Decimal Code	Hexadecimal Code
Bar Code Commands			
Select Bar Code Type and Size *	ESC DLE A m n ₁ ... n ₈	27 16 65 m n ₁ ... n ₈	1B 10 41 m n ₁ ... n ₈
Print Bar Code Data *	ESC DLE B m n [data]	27 16 66 m n [data]	1B 10 42 m n [data]
Print Postnet Bar Code Data *	ESC DLE C n [data]	27 16 67 n [data]	1B 10 43 n [data]
Character Sets			
Select International Character Set	ESC R n	27 82 n	1B 52 n
Select Epson Character Set	ESC t n	27 116 n	1B 74 n
Permit Printing of Upper Range Control Codes	ESC 6 or ESC I 1	27 54 or 27 73 1	1B 36 or 1B 49 01
Cancel Printing of Upper Range Control Codes	ESC 7 or ESC I 0	27 55 or 27 73 0	1B 37 or 1B 49 00
Character table selection	ESC (t Ln Hn Pn1 Pn2 Pn3	27 40 116 Ln Hn Pn1 Pn2 Pn3	1B 28 74 Ln Hn Pn1 Pn2 Pn3
Character Size/Spacing			
Select 10 cpi Pitch	ESC P	27 80	1B 50
Select 12 cpi Pitch	ESC M	27 77	1B 4D
Select 15 cpi Pitch	ESC g	27 103	1B 67
Select 20 cpi Pitch	ESC SI	27 15	1B 0F
Cancel 20 cpi Pitch	DC 2	18	12
Set Compressed Pitch	SI	15	0F
Superscript Printing On	ESC S 1	27 83 1	1B 53 01
Subscript Printing On	ESC S 0	27 83 0	1B 53 00
Superscript/Subscript Printing Off	ESC T	27 84	1B 54
Begin Double Width Printing Line by Line	ESC SO	27 14	1B 0E
End Double Width Printing Line by Line	DC 4	20	14
Double Width Printing On	ESC W 1	27 87 1	1B 57 01
Double Width Printing Off	ESC W 0	27 87 0	1B 57 00

Epson Function	ASCII Code	Decimal Code	Hexadecimal Code
Character Size/Spacing (cont.)			
Double Height Printing On	ESC w n	27 119 n	1B 77 n
Proportional Spacing On	ESC p 1	27 112 1	1B 70 01
Proportional Spacing Off	ESC p 0	27 112 0	1B 70 00
Set Intercharacter Spacing	ESC SP n	27 32 n	1B 20 n
Character Style			
Select HSD Print Mode *	ESC (n	27 40 n	1B 28 n
Select Utility Print Mode	ESC x 0	27 120 0	1B 78 00
Select font by Pitch and Point	ESC X Pn Lp Hp	27 88 Pn Lp Hp	1B 58 Pn Lp Hp
Select NLQ Print Mode	ESC k n	27 107 n	1B 6B n
Composite Command	ESC ! n	27 33 n	1B 21 n
Italics On	ESC 4	27 52	1B 34
Italics Off	ESC 5	27 53	1B 35
Emphasized Printing On	ESC E	27 69	1B 45
Emphasized Printing Off	ESC F	27 70	1B 46
Enhanced Printing On	ESC G	27 71	1B 47
Enhanced Printing Off	ESC H	27 72	1B 48
Underline On	ESC - 1	27 45 1	1B 2D 01
Underline Off	ESC - 0	27 45 0	1B 2D 00
Custom Characters			
Down Line Load Custom Characters	ESC & 0 n ₁ n ₂ a [data]	27 38 0 n ₁ n ₂ a [data]	1B 26 00 n ₁ n ₂ a [data]
Copy ROM Character Set to RAM Character Set	ESC : 0 n 0	27 58 0 n 0	1B 3A 0 n 0
Custom Character Set On	ESC % 0	27 37 0	1B 25 00
Custom Character Set Off	ESC % 1	27 37 1	1B 25 01
Cut Sheet Feeder Control			
Insert/Eject Paper	ESC EM n	27 25 n	1B 19 n
Graphics			
Single Density Graphics	ESC K L _n H _n [data]	27 75 L _n H _n [data]	1B 4B L _n H _n [data]
Double Density Graphics	ESC L L _n H _n [data]	27 76 L _n H _n [data]	1B 4C L _n H _n [data]
Double Speed/Double Density Graphics	ESC Y L _n H _n [data]	27 89 L _n H _n [data]	1B 59 L _n H _n [data]
Quadruple Density Graphics	ESC Z L _n H _n [data]	27 90 L _n H _n [data]	1B 5A L _n H _n [data]

Epson Function	ASCII Code	Decimal Code	Hexadecimal Code
Graphics (cont.) Graphics Select/Print Reassign Graphics Select 9-pin Graphics Printing	ESC * m L _n H _n [data] ESC ? m n ESC ^ m L _n H _n [data]	27 42 m L _n H _n [data] 27 63 m n 27 94 m L _n H _n [data]	1B 2A m L _n H _n [data] 1B 3F m n 1B 5E m L _n H _n [data]
Horizontal Control Backspace Carriage Return Margin Setting, Left Margin Setting, Right Horizontal Tab Set Horizontal Tab Clear Horizontal Tab Settings Set Print Position Set Absolute Dot Position Set Relative Dot Position Uni-directional Print On Uni-directional Print Off Print Uni-directional for One Line	BS CR ESC I n ESC Q n HT ESC D n ₁ n ₂ ... n _k 0 ESC D 0 0 ESC DLE @ P _n A ₁ A ₂ P ₁ P ₂ P ₃ P ₄ ESC \$ L _n H _n ESC \ L _n H _n ESC U 1 ESC U 0 ESC <	8 13 27 108 n 27 81 n 9 27 68 n ₁ n ₂ ... n _k 0 27 68 0 0 27 16 64 P _n A ₁ A ₂ P ₁ P ₂ P ₃ P ₄ 27 36 L _n H _n 27 92 L _n H _n 27 85 1 27 85 0 27 60	08 0D 1B 6C n 1B 51 n 09 1B 44 n ₁ n ₂ ... n _k 00 1B 44 00 00 1B 10 40 P _n A ₁ A ₂ P ₁ P ₂ P ₃ P ₄ 1B 24 L _n H _n 1B 5C L _n H _n 1B 55 01 1B 55 00 1B 3C
Vertical Control Page Length, Set in n Inches Page Length, Set in Lines Skip Over Perforation Set Skip Over Perforation Reset to Default Form Feed Line Feed Perform ⁿ / ₂₁₆ " Line Feed Perform ⁿ / ₁₄₄ " Line Feed * n/216" Reverse Line Feed Set Line Spacing to ¹ / ₆ " Set Line Spacing to ¹ / ₈ " Set Line Spacing to ⁷ / ₇₂ " Set Line Spacing to ⁿ / ₇₂ " Set Line Spacing to ⁿ / ₁₄₄ "*	ESC C 0 n ESC C n ESC N n ESC O FF LF ESC J n ESC % 5 n ESC j n ESC 2 ESC 0 ESC 1 ESC A n ESC % 9 n	27 67 0 n 27 67 n 27 78 n 27 79 12 10 27 74 n 27 37 53 n 27 106 n 27 50 27 48 27 49 27 65 n 27 37 57 n	1B 43 00 n 1B 43 n 1B 4E n 1B 4F 0C 0A 1B 4A n 1B 25 35 n 1B 6A n 1B 32 1B 30 1B 31 1B 41 n 1B 25 39 n

Epson Function	ASCII Code	Decimal Code	Hexadecimal Code
Vertical Control (cont.)			
Set Line Spacing to $n/_{216}$ " Vertical Tab	ESC 3 n VT	27 51 n 11	1B 33 n 0B
Set Vertical Tab Stops	ESC B $n_1 n_2 \dots n_k 0$	27 66 $n_1 n_2 \dots n_k 0$	1B 42 $n_1 n_2 \dots n_k 00$
Line feed compound command	ESC DLE H Pno A1 A2 P1 P2 P3	27 16 72 Pno A1 A2 P1 P2 P3	1B 10 48 Pno A1 A2 P1 P2 P3
Reset Vertical Tab to Defaults	ESC B 0	27 66 0	1B 42 00
Set Vertical Format Unit (VFU)	ESC b m $n_1 n_2 \dots n_k 0$	27 98 m $n_1 n_2 \dots n_k$ 0	1B 62 m $n_1 n_2 \dots n_k 0$
Set Vertical Tab Channel	ESC/n	27 47 n	1B 2Fn
Miscellaneous			
Cancel	CAN	24	18
Change Emulation *	ESC { n	27 123 n	1B 7B n
Delete One Character	DEL	127	7F
Initialize Printer	ESC @	27 64	1B 40
Half-Speed Printing On	ESC s 1	27 115 1	1B 73 0
Half-Speed Printing Off	ESC s 0	27 115 0	1B 73 00
Paper-Out Sensor On *	ESC 9	27 57	1B 39
Paper-Out Sensor Off *	ESC 8	27 56	1B 38
Print Suppress Mode On	DC3	19	13
Print Suppress Mode Off	DC1	17	11
Set Most Significant Bit to Zero	ESC =	27 61	1B 3D
Set Most Significant Bit to One	ESC >	27 62	1B 3E
Incremental print mode On, Off	ESC i n	27 105 n	1B 69 n
Cancel Most Significant Bit Control	ESC #	27 35	1B 23
Software I-Prime *	ESC } 0	27 125 0	1B 7D 00
Justification			
Left Justification	ESC a 0	27 97 0	1B 61 00
Center Justification	ESC a 1	27 97 1	1B 61 01
Right Justification	ESC a 2	27 97 2	1B 61 02
Within Line Justification	ESC a 3	27 97 3	1B 61 03

* OKI-Unique Command

OKI Microline (ML) Printer Commands

Microline Function	ASCII Code	Decimal Code	Hexadecimal Code
Bar Code Commands			
Select Bar Code Type and Size	ESC DLE A m n ₁ ... n ₈	27 16 65 m n ₁ ... n ₈	1B 10 41 m n ₁ ... n ₈
Print Bar Code Data	ESC DLE B n [data]	27 16 66 n [data]	1B 10 42 n [data]
Print Postnet Bar Code Data	ESC DLE C n [data]	27 16 67 n [data]	1B 10 43 n [data]
Character Sets			
Select Standard Character Set	ESC ! 0	27 33 48	1B 21 30
Select Line Character Set (comparable to IBM Set 2)	ESC ! 2	27 33 50	1B 21 32
Block character set	ESC ! 1	27 33 49	1B 21 31
Select International Character Set	ESC ! n	27 33 n	1B 21 n
Select Code Page	ESC [T L _n H _n 0 0 H _{cp} L _{cp} 0	27 91 84 L _n H _n 0 0 H _{cp} L _{cp} 0	1B 5B 54 L _n H _n 0 0 H _{cp} L _{cp} 0
Character Size/Spacing			
Select 10 cpi Pitch	RS	30	1E
Select 12 cpi Pitch	FS	28	1C
Select 15 cpi Pitch	ESC g	27 103	1B 67
Select 17.1 cpi Pitch	GS	29	1D
Select 20 cpi Pitch	ESC # 3	27 35 51	1B 23 33
Superscript Printing On	ESC J	27 74	1B 4A
Superscript Printing Off	ESC K	27 75	1B 4B
Subscript Printing On	ESC L	27 76	1B 4C
Subscript Printing Off	ESC M	27 77	1B 4D
Double Width Printing	US	31	1F
Double Height Printing On	ESC US 1	27 31 49	1B 1F 31
Double Height Printing Off	ESC US 0	27 31 48	1B 1F 30
Select Print Mode	ESC & n ₁ n ₂ n ₃ n ₄ :	27 38 n ₁ n ₂ n ₃ n ₄ 58	1B 26 n ₁ n ₂ n ₃ n ₄ 3A
Proportional Spacing On	ESC Y	27 89	1B 59
Proportional Spacing Off	ESC Z	27 90	1B 5A
Set Intercharacter Spacing	ESC N n	27 78 n	1B 4E n

Microline Function	ASCII Code	Decimal Code	Hexadecimal Code
Character Style			
HSD Print Mode On	ESC # 0	27 35 48	1B 23 30
Select Utility Print Mode	ESC 0	27 48	1B 30
Select NLQ Courier Font	ESC 1	27 49	1B 31
Select NLQ Gothic Font	ESC 3	27 51	1B 33
Select Font by Pitch and Point	ESC DLE F P _{n0} P _n L _p Hp	27 16 70 P _{n0} P _n L _p Hp	1B 10 46 P _{n0} P _n L _p Hp
Italics On	ESC ! /	27 33 47	1B 21 2F
Italics Off	ESC ! *	27 33 42	1B 21 2A
Emphasized Printing On	ESC T	27 84	1B 54
Enhanced Printing On	ESC H	27 72	1B 48
Emphasized and Enhanced Printing Off	ESC I	27 73	1B 49
Underline On	ESC C	27 67	1B 43
Underline Off	ESC D	27 68	1B 44
Custom Characters			
Copy ROM Character Set to RAM Character Set	ESC \$	27 36	1B 24
Download Custom Ascender Characters	ESC % A m n ₁ ... n ₁₁	27 37 65 m n ₁ ... n ₁₁	1B 25 41 m n ₁ ... n ₁₁
Download Custom Descender Characters	ESC % D m n ₁ ... n ₁₁	27 37 68 m n ₁ ... n ₁₁	1B 25 44 m n ₁ ... n ₁₁
Select DLL Utility Character Font	ESC 2	27 50	1B 32
Select Down Line Load NLQ Character Font	ESC 7	27 55	1B 37
Cut Sheet Feeder Control			
Cut Sheet Feeder Insert Sheet	ESC S	27 83	1B 53
Cut Sheet Feeder Sheet Eject	ESC V	27 86	1B 56
Cut Sheet Feeder Bin 1 or Bin 2 Selection	ESC EM n	27 25 n	1B 19 n
Graphics			
Single Density Graphics	ESC P or ESC Q	27 80 or 27 81	1B 50 or 1B 51
Double Density Graphics	ESC R	27 82	1B 52
Double Speed/Quadruple Density Graphics	ESC # Q	27 35 81	1B 23 51

Microline Function	ASCII Code	Decimal Code	Hexadecimal Code
Graphics (cont.) Graphics Mode Selection Graphics Print Mode Selection	ESC * n ₁ n ₂ : ETX	27 42 n ₁ n ₂ 58 3	1B 2A n ₁ n ₂ 3A 03
Horizontal Control Backspace Carriage Return Horizontal Tab Margin Setting, Left Margin Setting, Right Move to the Left Move to the Right Set Print Position Set Multiple Print Positions Set Horizontal Tab by Characters Set Horizontal Tab by Dot Columns Clear Horizontal Tab Settings Uni-directional Print On Uni-directional Print Off	BS CR HT ESC % C n ₁ n ₂ n ₃ ESC % R n ₁ n ₂ n ₃ n ₄ ESC % F n ₁ n ₂ n ₃ n ₄ ESC % E n ₁ n ₂ n ₃ n ₄ ESC % B n ₁ n ₂ n ₃ n ₄ ESC DEL @ P _n a ₁ a ₂ P ₁ P ₂ P ₃ P ₄ ESC HT x y z CR ESC HTX x y z w CR ESC HT CR ESC - ESC =	8 13 9 27 37 67 n ₁ n ₂ n ₃ 27 37 82 n ₁ n ₂ n ₃ n ₄ 27 37 70 n ₁ n ₂ n ₃ n ₄ 27 37 69 n ₁ n ₂ n ₃ n ₄ 27 37 66 n ₁ n ₂ n ₃ n ₄ 27 16 64 P _n a ₁ a ₂ P ₁ P ₂ P ₃ P ₄ 27 9 x y z 13 27 3 x y z w 13 27 9 13 27 45 27 61	08 0D 09 1B 25 43 n ₁ n ₂ n ₃ 1B 25 52 n ₁ n ₂ n ₃ n ₄ 1B 25 46 n ₁ n ₂ n ₃ n ₄ 1B 25 45 n ₁ n ₂ n ₃ n ₄ 1B 25 42 n ₁ n ₂ n ₃ n ₄ 1B 10 40 P _n a ₁ a ₂ P ₁ P ₂ P ₃ P ₄ 1B 09 x y z 0D 1B 03 x y z w 0D 1B 09 0D 1B 2D 1B 3D
Vertical Control Page Length, Set in 1/2" Increments Page Length, Set in Lines Skip Over Perforation On Skip Over Perforation Off Set Top of Form Form Feed Skip Down Selected Number of Lines Line Feed (with Carriage Return) Line Feed (without Carriage Return) Carriage Return/Line Feed Selection Command	ESC G H _n L _n ESC F H _n L _n ESC % S n ESC % S 0 ESC 5 FF ESC VT H _n L _n LF ESC DC2 ESC ? n :	27 71 H _n L _n 27 70 H _n L _n 27 37 83 n 27 37 83 0 27 53 12 27 11 H _n L _n 10 27 18 25 63 n 58	1B 47 H _n L _n 1B 46 H _n L _n 1B 25 53 n 1B 25 53 00 1B 35 0C 1B 0B H _n L _n 0A 1B 12 1B 3F n 3A

Microline Function	ASCII Code	Decimal Code	Hexadecimal Code
Vertical Control (cont.)			
Perform $n/_{144}$ " Line Feed	ESC % 5 n	27 37 53 n	1B 25 35 n
Reverse Line Feed	ESC LF	27 10	1B 0A
Set Line Spacing to $1/_{8}$ "	ESC 8	27 56	1B 38
Set Line Spacing to $1/_{6}$ "	ESC 6	27 54	1B 36
Set Line Spacing to $n/_{144}$ "	ESC % 9 n	27 37 57 n	1B 25 39 n
Vertical Tab	VT	11	0B
Execute VFU Vertical Tab	VT n	11 n	0B n
Set Vertical Tab Channels	DC4 SP...SP n SP...SP?	20 32...32n 32...32 63	14 20...20 n 20...20 3F
Line feed compound command	ESC DLE H Pno A1 A2 P1 P2 P3	27 16 72 Pno A1 A2 P1 P2 P3	1B 10 48 Pno A1 A2 P1 P2 P3
Miscellaneous			
Cancel	CAN	24	18
Initialize Printer	ESC CAN	27 24	1B 18
Half-Speed Printing On	ESC <	27 60	1B 3C
Half-Speed Printing Off	ESC >	27 62	1B 3E
Change Emulation	ESC { n	27 123 n	1B 7B n
Paper-Out Sensor On	ESC E 0	27 69 0	1B 45 00
Paper-Out Sensor Off	ESC E 1	27 69 1	1B 45 01
Print Suppress Mode On	DC3	19	13
Print Suppress Mode Off	DC1	17	11
Software I-Prime	ESC } 0	27 125 0	1B 7D 00
Incremental print mode On, Off	ESC i n	27 105 n	1B 69 n

Appendix D: ASCII Character Codes

Lower ASCII Character Sets

Lower ASCII Character Sets (1/4)

Hex.	Dec.	Epson Set 1	Epson Set 2	IBM Set 1	IBM Set 2 ML Line Graphics	IBM Set 3	ML Standard & Block Graphics
00	0	NUL	NUL	NUL	NUL	∅	
01	1					⊙	
02	2					●	STX
03	3				♥	♥	ETX
04	4				♦	♦	
05	5				♣	♣	
06	6				♠	♠	
07	7					•	
08	8	BS	BS	BS	BS	■	BS
09	9	HT	HT	HT	HT	○	HT
0A	10	LF	LF	LF	LF	■	LF
0B	11	VT	VT	VT	VT	♀	VT
0C	12	FF	FF	FF	FF	♀	FF
0D	13	CR	CR	CR	CR	♪	CR
0E	14	SO	SO	SO	SO	♪	SO
0F	15	SI	SI	SI	SI	♁	SI
10	16					▶	
11	17	DC1	DC1	DC1	DC1	◀	DC1
12	18	DC2	DC2	DC2	DC2	↑	DC2
13	19	DC3	DC3	DC3	DC3		DC3
14	20	DC4	DC4	DC4	DC4	¶	DC4
15	21		§		§	§	
16	22					-	
17	23					↑	
18	24	CAN	CAN	CAN	CAN	↑	CAN
19	25	EM	EM	EM	EM	↓	EM
1A	26					→	
1B	27	ESC	ESC	ESC	ESC	←	ESC
1C	28				FS	└	FS
1D	29				GS	↔	GS
1E	30				RS	▲	RS
1F	31				US	▼	US
20	32	Space	Space	Space	Space	Space	Space

Lower ASCII Character Sets (2/4)

Hex.	Dec.	Epson Sets 1 & 2	IBM Set 1	IBM Set 2 ML Line Graphics	IBM Set 3	ML Standard & Block Graphics
21	33	!	!	!	!	!
22	34	"	"	"	"	"
23	35	#	#	#	#	#
24	36	\$	\$	\$	\$	\$
25	37	%	%	%	%	%
26	38	&	&	&	&	&
27	39
28	40	(((((
29	41)))))
2A	42	*	*	*	*	*
2B	43	+	+	+	+	+
2C	44	,	,	,	,	,
2D	45	-	-	-	-	-
2D	46
2F	47	/	/	/	/	/
30	48	0	0	0	0	0
31	49	1	1	1	1	1
32	50	2	2	2	2	2
33	51	3	3	3	3	3
34	52	4	4	4	4	4
35	53	5	5	5	5	5
36	54	6	6	6	6	6
37	55	7	7	7	7	7
38	56	8	8	8	8	8
39	57	9	9	9	9	9
3A	58	:	:	:	:	:
3B	59	;	;	;	;	;
3C	60	<	<	<	<	<
3D	61	=	=	=	=	=
3E	62	>	>	>	>	>
3F	63	?	?	?	?	?
40	64	@	@	@	@	@
41	65	A	A	A	A	A

Lower ASCII Character Sets (3/4)

Hex.	Dec.	Epson Sets 1 & 2	IBM Set 1	IBM Set 2 ML Line Graphics	IBM Set 3	ML Standard & Block Graphics
42	66	B	B	B	B	B
43	67	C	C	C	C	C
44	68	D	D	D	D	D
45	69	E	E	E	E	E
46	70	F	F	F	F	F
47	71	G	G	G	G	G
48	72	H	H	H	H	H
49	73	I	I	I	I	I
4A	74	J	J	J	J	J
4B	75	K	K	K	K	K
4C	76	L	L	L	L	L
4D	77	M	M	M	M	M
4E	78	N	N	N	N	N
4F	79	O	O	O	O	O
50	80	P	P	P	P	P
51	81	Q	Q	Q	Q	Q
52	82	R	R	R	R	R
53	83	S	S	S	S	S
54	84	T	T	T	T	T
55	85	U	U	U	U	U
56	86	V	V	V	V	V
57	87	W	W	W	W	W
58	88	X	X	X	X	X
59	89	Y	Y	Y	Y	Y
5A	90	Z	Z	Z	Z	Z
5B	91	[[[[[
5C	92	\	\	\	\	\
5D	93]]]]]
5E	94	^	^	^	^	^
5F	95	`	`	`	`	`
60	96	~	~	~	~	~

Lower ASCII Character Sets (4/4)

Hex.	Dec.	Epson Sets 1 & 2	IBM Set 1	IBM Set 2 ML Line Graphics	IBM Set 3	ML Standard & Block Graphics
61	97	a	a	a	a	a
62	98	b	b	b	b	b
63	99	c	c	c	c	c
64	100	d	d	d	d	d
65	101	e	e	e	e	e
66	102	f	f	f	f	f
67	103	g	g	g	g	g
68	104	h	h	h	h	h
69	105	i	i	i	i	i
6A	106	j	j	j	j	j
6B	107	k	k	k	k	k
6C	108	l	l	l	l	l
6D	109	m	m	m	m	m
6E	110	n	n	n	n	n
6F	111	o	o	o	o	o
70	112	p	p	p	p	p
71	113	q	q	q	q	q
72	114	r	r	r	r	r
73	115	s	s	s	s	s
74	116	t	t	t	t	t
75	117	u	u	u	u	u
76	118	v	v	v	v	v
77	119	w	w	w	w	w
78	120	x	x	x	x	x
79	121	y	y	y	y	y
7A	122	z	z	z	z	z
7B	123	{	{	{	{	{
7C	124					
7D	125	}	}	}	}	}
7E	126	~	~	~	~	~
7F	127	DEL	~	~	␣	■

Upper ASCII Character Sets

Upper ASCII Character Sets (1/4)

Hex.	Dec.	Epson Set 1	Epson Set 2	IBM Set 1	IBM Set 2 ML Line Graphics	ML Standard	ML Block Graphics
80	128	NUL	Ç	NUL	Ç	NUL	.
81	129		ù		ù		.
82	130		é		é	STX	.
83	131		â		â	ETX	.
84	132		â		â		.
85	133		à		à		.
86	134		á		á		.
87	135		ç		ç		.
88	136	BS	ê	BS	ê	BS	.
89	137	HT	è	HT	è	HT	.
8A	138	LF	è	LF	è	LF	.
8B	139	VT	ï	VT	ï	VT	.
8C	140	FF	ï	FF	ï	FF	.
8D	141	CR	ì	CR	ì	CR	.
8E	142	SO	À	SO	À	SO	.
8F	143	SI	À	SI	À	SI	.
90	144		É		É		.
91	145	DC1	æ	DC1	æ	DC1	.
92	146	DC2	Æ	DC2	Æ	DC2	.
93	147	DC3	ø		ø	DC3	.
94	148	DC4	ø	DC4	ø	DC4	.
95	149		ò		ò		.
96	150		ù		ù		.
97	151		ù		ù		.
98	152	CAN	ÿ	CAN	ÿ	CAN	.
99	153	EM	Û	EM	Û	EM	.
9a	154		Û		Û		.
9B	155	ESC	€	ESC	€	ESC	.
9C	156		£		£	FS	.
9D	157		¥		¥	GS	.
9E	158		¤		¤	RS	.
9F	159		f		f	US	.
A0	160	Space	á	á	á	á	.

Upper ASCII Character Sets (2/4)

Hex.	Dec.	Epson Set 1	Epson Set 2	IBM Sets 1, 2 & 3 ML Standard	ML Block Graphics
A1	161	!	í	í	
A2	162	"	ó	ó	
A3	163	#	ú	ú	
A4	164	\$	ñ	ñ	
A5	165	%	Ñ	Ñ	
A6	166	&	•	•	
A7	167	'	•	•	
A8	168	(¿	¿	
A9	169)	¡	¡	
AA	170	*	¡	¡	
AB	171	+	½	½	
AC	172	,	¼	¼	
AD	173	-	¡	¡	
AE	174	.	•	•	
AF	175	/	•	•	
B0	176	0			
B1	177	1			
B2	178	2			
B3	179	3			
B4	180	4			
B5	181	5			
B6	182	6			
B7	183	7			
B8	184	8			
B9	185	9			
BA	186	:			
BB	187	;			
BC	188	<			
BD	189	=			
BE	190	>			
BF	191	?			
C0	192	@			
C1	193	A			

Upper ASCII Character Sets (3/4)

Hex.	Dec.	Epson Set 1	Epson Set 2	IBM Sets 1, 2 & 3 ML Standard	ML Block Graphics
C2	194	B	⌈	⌈	·
C3	195	C	⌋	⌋	·
C4	196	D	—	—	·
C5	197	E	⌈	⌈	·
C6	198	F	⌋	⌋	·
C7	199	G	⌈	⌈	·
C8	200	H	⌋	⌋	·
C9	201	I	⌈	⌈	·
CA	202	J	⌋	⌋	·
CB	203	K	⌈	⌈	·
CC	204	L	⌋	⌋	·
CD	205	M	⌈	⌈	·
CE	206	N	⌋	⌋	·
CF	207	O	⌈	⌈	·
D0	208	P	⌋	⌋	·
D1	209	Q	⌈	⌈	·
D2	210	R	⌋	⌋	·
D3	211	S	⌈	⌈	·
D4	212	T	⌋	⌋	·
D5	213	U	⌈	⌈	·
D6	214	V	⌋	⌋	·
D7	215	W	⌈	⌈	·
D8	216	X	⌋	⌋	·
D9	217	Y	⌈	⌈	·
DA	218	Z	⌋	⌋	·
DB	219	{	■	■	·
DC	220	\	■	■	·
DD	221	}	■	■	·
DE	222	^	■	■	·
DF	223	-	■	■	·
E0	224	`	α	α	·

Upper ASCII Character Sets (4/4)

Hex.	Dec.	Epson Set 1	Epson Set 2	IBM Sets 1, 2 & 3 ML Standard	ML Block Graphics
E1	225	a	β	β	
E2	226	b	Γ	Γ	
E3	227	c	π	π	
E4	228	d	Σ	Σ	
E5	229	e	σ	σ	
E6	230	f	μ	μ	
E7	231	g	τ	τ	
E8	232	h	Φ	Φ	
E9	233	ι	Θ	Θ	
EA	234	ϰ	Ω	Ω	
EB	235	k	δ	δ	
EC	236	l	∞	∞	
ED	237	m	ø	ø	
EE	238	n	ε	ε	
EF	239	o	∩	∩	
F0	240	p	≡	≡	
F1	241	q	±	±	
F2	242	r	≥	≥	
F3	243	s	≤	≤	
F4	244	t	∫	∫	
F5	245	u	∫	∫	
F6	246	v	÷	÷	
F7	247	w	≈	≈	
F8	248	x	◦	◦	
F9	249	y	•	•	
FA	250	z	•	•	
FB	251	{	√	√	
FC	252		n	n	
FD	253	}	₂	₂	
FE	254	~	■	■	
FF	255	DEL	Space	Space	

Epson International Character Substitutions

	35	36	38	64	79	91	92	93	94	95	96	123	124	125	126
American	#	\$	&	@	o	[\]	^	-	`	{		}	~
British	£	\$	&	@	o	[\]	^	_	`	{		}	~
Danish I	#	\$	&	@	o	Æ	Ø	Å	^	_	`	æ	ø	å	~
Danish II	#	\$	&	É	o	Æ	Ø	Å	Û	_	é	æ	ø	å	ü
Dutch	£	\$	&	@	o	[Π]	^	_	`	{	ij	}	~
French	#	\$	&	à	o	'	ç	§	^	_	`	é	ù	è	¨
French Canadian	ü	\$	è	à	Ø	à	ç	è	î	ï	Ô	é	ù	è	û
German	#	\$	&	§	o	Ä	Ö	Ü	^	_	`	ä	ö	ü	ß
Italian	#	\$	&	@	o	'	\	é	^	_	ù	à	ò	è	í
Japanese	#	\$	&	@	o	[¥]	^	_	`	{		}	~
Latin American	#	\$	&	á	o	i	Ñ	¿	é	_	ü	í	ñ	ó	ú
Norwegian	#	o	&	É	o	Æ	Ø	Å	Û	_	é	æ	ø	å	ü
Publisher	#	\$	&	§	o	°	'	"	¶	_	`	©	®	†	™
Spanish I	ñ	\$	&	@	o	i	Ñ	¿	^	_	`	í	ñ	}	~
Spanish II	#	\$	&	á	o	i	Ñ	¿	é	_	`	í	ñ	ó	ú
Swedish	#	o	&	É	o	Ä	Ö	Å	Û	_	é	ä	ö	å	ü

IBM International Character Substitutions

	35	36	38	48	64	79	91	92	93	94	95	96	123	124	125	126	
American (slashed zero)	#	\$	&	0	@	○	[\]	^	_	`	{		}	~	
American (unslashed zero)	#	\$	&	0	@	○	[\]	^	_	`	{		}	~	
British	£	\$	&	0	@	○	[\]	^	_	`	{		}	~	
Danish	#	\$	&	0	@	○	Æ	Ø	Å	Û	_	`	æ	ø	å	ü	
Dutch	£	\$	&	0	@	○	[Π]	^	_	`	{	Π	}	~	
French	£	\$	&	0	à	○	·	ç	§	^	_	`	é	ü	è	ê	
French Canadian	ü	\$	ë	0	à	Ø	á	ç	ê	î	ï	ô	é	ù	è	û	
German	#	\$	&	0	§	○	Ä	Ö	Ü	^	_	`	ä	ö	ú	ß	
Italian	£	\$	&	0	§	○	·	ç	é	^	_	`	ù	à	ò	è	ì
Latin American	#	\$	&	0	á	○	í	Ñ	¿	é	_	`	ü	í	ñ	ó	ú
Norwegian	#	\$	&	0	@	○	Æ	Ø	Å	^	_	`	æ	ø	å	~	
Publisher	#	\$	&	0	§	○	°	'	"	¶	_	`	©	®	†	™	
Spanish	!	\$	&	0	¡	○	Ñ	ñ	¿	ü	_	`	á	é	í	ó	ú
Swedish	§	□	&	0	É	○	Ä	Ö	Å	^	_	`	é	ä	ö	å	ü

MICROLINE International Character Substitutions

	35	36	38	48	64	79	91	92	93	94	95	96	123	124	125	126
American (slashed zero)	#	\$	&	Ø	@	Ö	[\]	^	_	'	{		}	~
American (unslashed zero)	#	\$	&	0	@	Ö	[\]	^	_	'	{		}	~
British	£	\$	&	0	@	Ö	[\]	^	_	'	{		}	~
Danish	#	\$	&	0	@	Ö	Æ	Ø	Å	Û	_	`	æ	ø	å	ü
Dutch	£	\$	&	0	@	Ö	[Π]	^	_	'	{	ij	}	~
French	£	\$	&	0	à	Ö	·	ç	§	^	_	'	é	ü	è	ê
French Canadian	ü	\$	ë	0	à	Ø	â	ç	ê	î	ï	ô	é	ù	è	û
German	#	\$	&	0	§	Ö	Ä	Ö	Û	^	_	'	ä	ö	ü	ß
Italian	£	\$	&	0	§	Ö	·	ç	é	^	_	ù	à	ò	è	ì
Norwegian	#	\$	&	0	@	Ö	Æ	Ø	Å	^	_	·	æ	ø	å	~
Publisher	#	\$	&	0	§	Ö	·	'	¨	¶	±	`	©	®	†	™
Spanish	!	\$	&	0	¡	Ö	Ñ	ñ	¿	ü	_	á	é	í	ó	ú
Swedish	§	□	&	0	É	Ö	Ä	Ö	Å	^	_	é	ä	ö	å	ü

Code Page Character Sets

The characters in the lower ASCII range (hexadecimal 00 through 7F, decimal 0 through 127) are the same as IBM Set 3. The characters for the upper ASCII range are given in the tables below.

Code Page Character Sets (1/4)

Hex.	Dec.	Code Page						
		1 USA	2 USA Multilingual	3 Canadian French	4 Portugal	5 Norway	6 BRASCI	7 Abicomp
80	128	Ç	Ç	Ç	Ç	Ç		
81	129	ù	ù	ù	ù	ù		
82	130	é	é	é	é	é		
83	131	â	â	â	â	â		
84	132	à	à	À	à	à		
85	133	à	à	à	à	à		
86	134	á	á	¶	Á	á		
87	135	ç	ç	ç	ç	ç		
88	136	ê	ê	ê	ê	ê		
89	137	ë	ë	ë	Ê	ë		
8A	138	è	è	è	è	è		
8B	139	í	í	í	Í	í		
8C	140	í	í	í	Ï	í		
8D	141	í	í	í	Ô	í		
8E	142	À	À	=	À	À		
8F	143	À	À	§	À	À		
90	144	É	É	É	É	É		
91	145	æ	æ	È	À	æ		
92	146	Æ	Æ	Ê	È	Æ		
93	147	ô	ô	ô	ô	ô		
94	148	ô	ô	Ë	ô	ô		
95	149	ò	ò	Ï	ò	ò		
96	150	ù	ù	ù	Ù	ù		
97	151	ù	ù	ù	ù	ù		
98	152	ÿ	ÿ	□	ÿ	ÿ		
99	153	Ö	Ö	Ö	Ö	Ö		
9a	154	Û	Û	Û	Û	Û		
9B	155	ø	ø	ø	ø	ø		
9C	156	£	£	£	£	£		
9D	157	¥	Ø	Û	Û	Ø		
9E	158	ƒ	X	Û	ƒ	ƒ		
9F	159	f	f	f	Ó	f		
A0	160	á	á		á	á		

Code Page Character Sets (2/4)

Hex.	Dec.	Code Page						
		1 USA	2 USA Multilingual	3 Canadian French	4 Portugal	5 Norway	6 BRASCII	7 Abicomp
A1	161	í	í	´	í	í	ı	À
A2	162	ó	ó	ó	ó	ó	€	Á
A3	163	ú	ú	ú	ú	ú	£	Â
A4	164	ñ	ñ	"	ñ	ñ	¤	Ã
A5	165	Ñ	Ñ	,	Ñ	Ñ	¥	Ä
A6	166	ª	ª	3	ª	ª	¦	Å
A7	167	º	º	-	º	º	§	Æ
A8	168	¿	¿	Í	¿	¿	¨	É
A9	169	¸	®	¸	Ò	¸	©	Ê
AA	170	¸	¸	¸	¸	¸	ª	Ë
AB	171	½	½	½	½	½	«	Ì
AC	172	¼	¼	¼	¼	¼	»	Í
AD	173	ı	ı	¾	ı	ı	-	Î
AE	174	ı	ı	ı	ı	ı	®	Ï
AF	175	ı	ı	ı	ı	ı	·	Ñ
B0	176	ı	ı	ı	ı	ı	•	Ó
B1	177	ı	ı	ı	ı	ı	±	Ô
B2	178	ı	ı	ı	ı	ı	²	Õ
B3	179	ı	ı	ı	ı	ı	³	Ö
B4	180	ı	ı	ı	ı	ı	´	Ø
B5	181	ı	Â	ı	ı	ı	µ	Ù
B6	182	ı	Â	ı	ı	ı	¶	Ú
B7	183	ı	Â	ı	ı	ı	·	Û
B8	184	ı	©	ı	ı	ı	¸	Ü
B9	185	ı	ı	ı	ı	ı	¸	Ý
BA	186	ı	ı	ı	ı	ı	¸	ı
BB	187	ı	ı	ı	ı	ı	»	ı
BC	188	ı	ı	ı	ı	ı	¼	ı
BD	189	ı	ı	ı	ı	ı	½	ı
BE	190	ı	ı	ı	ı	ı	¾	ı
BF	191	ı	ı	ı	ı	ı	ı	ı
C0	192	ı	ı	ı	ı	ı	ı	ı
C1	193	ı	ı	ı	ı	ı	ı	ı

Code Page Character Sets (3/4)

Hex.	Dec.	Code Page						
		1 USA	2 USA Multilingual	3 Canadian French	4 Portugal	5 Norway	6 BRASCII	7 Abicomp
C2	194	T	T	T	T	T	À	á
C3	195	†	†	†	†	†	Á	â
C4	196	—	—	—	—	—	Â	ã
C5	197	+	+	+	+	+	Ã	ä
C6	198	ƒ	â	ƒ	ƒ	ƒ	Ä	å
C7	199	ll	À	ll	ll	ll	Å	ç
C8	200	ll	Ä	ll	ll	ll	Ç	ê
C9	201	ff	ll	ff	ff	ff	È	é
CA	202	ll	ll	ll	ll	ll	É	ê
CB	203	ff	ff	ff	ff	ff	Ê	ë
CC	204	ll	ll	ll	ll	ll	Ë	ì
CD	205	=	=	=	=	=	Ì	í
CE	206	ll	ll	ll	ll	ll	Í	î
CF	207	ll	ø	ll	ll	ll	Î	ï
D0	208	ll	ö	ll	ll	ll	Ï	ð
D1	209	ff	Ð	ff	ff	ff	Ñ	ó
D2	210	ll	Ê	ll	ll	ll	Ò	ô
D3	211	ll	Ê	ll	ll	ll	Ó	õ
D4	212	ll	È	ll	ll	ll	Ô	ö
D5	213	f	í	f	f	f	Õ	ø
D6	214	ff	Í	ff	ff	ff	Ö	ù
D7	215	ll	Ï	ll	ll	ll	Ø	ú
D8	216	ll	Ï	ll	ll	ll	Ù	û
D9	217	ll	Ï	ll	ll	ll	Ú	ü
DA	218	ll	ll	ll	ll	ll	Û	ý
DB	219	ll	ll	ll	ll	ll	Ü	ÿ
DC	220	ll	ll	ll	ll	ll	Ý	ÿ
DD	221	ll	ll	ll	ll	ll	ÿ	ÿ
DE	222	ll	ll	ll	ll	ll	ÿ	ÿ
DF	223	ll	ll	ll	ll	ll	ÿ	ÿ
E0	224	α	Ó	α	α	α	à	+

Code Page Character Sets (4/4)

Hex.	Dec.	Code Page						
		1 USA	2 USA Multilingual	3 Canadian French	4 Portugal	5 Norway	6 BRASCII	7 Abicomp
E1	225	β	β	β	β	β	á	
E2	226	Γ	Ò	Γ	Γ	Γ	â	
E3	227	π	Ò	π	π	π	ã	
E4	228	Σ	ö	Σ	Σ	Σ	ä	
E5	229	σ	Õ	σ	σ	σ	å	
E6	230	μ	μ	μ	μ	μ	æ	
E7	231	τ	ρ	τ	τ	τ	ç	
E8	232	Φ	ρ	Φ	Φ	Φ	è	
E9	233	Θ	Ú	Θ	Θ	Θ	é	
EA	234	Ω	Û	Ω	Ω	Ω	ê	
EB	235	δ	Û	δ	δ	δ	ë	
EC	236	∞	ý	∞	∞	∞	í	
ED	237	ø	Ý	ø	ø	ø	î	
EE	238	ε	.	ε	ε	ε	ï	
EF	239	∩	.	∩	∩	∩	ï	
F0	240	≡	.	≡	≡	≡	ð	
F1	241	±	±	±	±	±	ñ	
F2	242	≥	=	≥	≥	≥	ó	
F3	243	≤	¾	≤	≤	≤	ô	
F4	244	∫	¶	∫	∫	∫	õ	
F5	245	J	§	J	J	J	ö	
F6	246	÷	+	+	+	+	ö	
F7	247	≈	.	≈	≈	≈	ø	
F8	248	°	°	°	°	°	ø	
F9	249	•	"	•	•	•	ú	
FA	250	·	.	·	·	·	ú	
FB	251	√	1	√	√	√	û	
FC	252	n	3	n	n	n	ü	
FD	253	²	2	²	²	²	ý	
FE	254	■	■	■	■	■	ÿ	
FF	255	Space	Space	Space	Space	Space		

Appendix E: Interfacing

This appendix gives the pin assignments for the parallel interface. It also explains how to install the optional Serial Interface Board and gives the pin assignments for the serial interface.

Pin Assignments for Parallel Interface Signals

Pin	Signal	Return Pin	Direction
1	Strobe	19	To Printer
2	Data 1	20	To Printer
3	Data 2	21	To Printer
4	Data 3	22	To Printer
5	Data 4	23	To Printer
6	Data 5	24	To Printer
7	Data 6	25	To Printer
8	Data 7	26	To Printer
9	Data 8	27	To Printer
10	Acknowledge	28	From Printer
11	Busy	29	From Printer
12	Paper End	30	From Printer
13	Select	No Return	From Printer
14	Auto Feed		To Printer
15	Not used		
16	0V	No Return	Signal Ground
17	Chassis Ground	No Return	Frame Ground
18	+5V *		From Printer
19-30	0V		Ground
31	Input Prime		To Printer
32	Fault		From Printer
33	0V		Signal Ground
34-	Not used		
35	Not used		High Level
36	Select In		To Printer

* 50 mA maximum

Universal Serial Bus (USB)

Universal Serial Bus Specification Revision 1.1 compliance.

1. Connector

- Printer Side: "B" Receptacle (Upstream Input to the USB Device)
- Cable Side: Series "B" Plug

2. Cable

- Cable Length: Max 5 m (A cable must be met USB Spec Rev 1.1 for normal operation)

Note: Cable is not provided.

3. Table of USB I/F signals

Contact Number	Signal Name
1	Vbus (Not Used)
2	D-
3	D+
4	GND
Sell	Shield

4. Connector pin arrangement

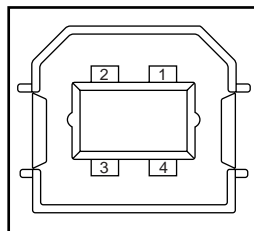

Installing the Serial Interface

Caution! Handle the interface board with care to avoid damaging its components. The components can also be damaged by static discharges. We recommend that you leave the board in its protective packaging until you've read these instructions and are ready to install it. Make sure the printer is unplugged before you install the board.

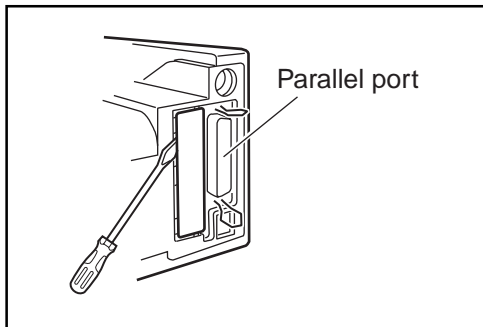

1. Remove plastic covering over opening for serial board in back panel:
 - insert tip of flat-blade screwdriver at top and twist it to snap plastic molding holding cover in place.
 - repeat procedure for molding at bottom of cover
 - press inward on cover with your fingers and bend it back and forth until it snaps off.

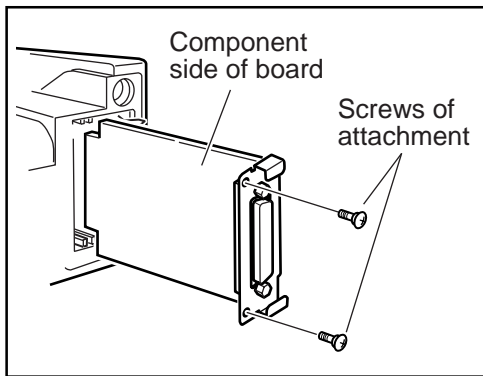

2. Holding board by cable connector, with components facing away from parallel interface, gently slide it into opening against guides at top and bottom. Press firmly into place.

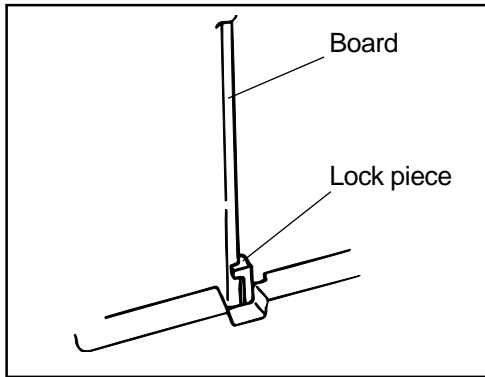

3. By inserting board to the far end, it is locked by the lock piece inside.

4. Connect suitable interface cable (must be purchased separately) to printer connector and to serial port of your computer. Be sure to tighten screws on both ends of cable to keep it in place.

Important! Make sure that you do not have a parallel cable connected to the printer when you're using the serial interface. You can switch to the parallel interface without removing the serial board, but *only one cable can be attached at a time*.

When the serial interface is installed, the "Serial I/F" portion of the Menu will become active (see page 73).

Pin Assignments for Serial Interface Signals

Pin	Signal	Symbol	Direction
1	Protective Ground	PG	
2	Transmitted Data	TD	From Printer
3	Received Data	RD	To Printer
4	Request to Send	RTS	From Printer
5	Not used		
6	Data Set Ready	DSR	To Printer
7	Signal Ground	SG	
8-10	Not Used		
11	Supervisory Send Data	SSD	From Printer
12-19	Not Used		
20	Data Terminal Ready	DTR	From Printer
21-25	Not Used		

OKI CONTACT DETAILS

Oki Data (Singapore) Pte. Ltd.
438A Alexandra Road #02-11/12,
Lobby 3, Alexandra Technopark
Singapore (119967)

Tel:(65) 6221 3722
Fax:(65) 6594 0609
<http://www.okidata.com.sg>

Oki Systems (Thailand) Ltd.
1168/79, 81-82 Lumpini Tower,
27th Floor, Rama IV Road,
Tungmahamek, Sathorn
Bangkok 10120,
Thailand

Tel:(+662) 679 9235
Fax:(+662) 679 9245
<http://www.okisysthai.com>

Oki Data (Australia) Pty. Ltd.
Level1 67 Epping Road, Macquarie Park
NSW 2113, Australia

Tel: +61 2 8071 0000
(Support Tel: 1800 807 472)
Fax:+61 2 8071 0010
<http://www.oki.com.au>

Comworth Systems Ltd.
8 Antares Place Rosedale,
Auckland 0632, New Zealand

Tel:(64) 9 477 0500
Fax:(64) 9 477 0549
<http://www.comworth.co.nz>

Oki Data(S) P Ltd.Malaysia Rep Office
Suite 21.03, 21st Floor Menara IGB,
Mid Valley City,
Lingkaran Syed Pura 59200,
Kuala Lumpur, Malaysia

Tel:(60) 3 2287 1177
Fax:(60) 3 2287 1166

OKI

Oki Data Corporation
4-11-22, Shibaura, Minato-ku
Tokyo 108-8551 Japan

42089205EE Rev.2