

**User's Guide**



**59376401**

# Preface

ES3640e MFP User's Guide

P/N 59376401, Revision 1.2

May, 2006

Every effort has been made to ensure that the information in this document is complete, accurate, and up-to-date. Oki assumes no responsibility for the results of errors beyond its control. Oki also cannot guarantee that changes in software and equipment made by other manufacturers and referred to in this guide will not affect the applicability of the information in it. Mention of software products manufactured by other companies does not necessarily constitute endorsement by Oki.

While all reasonable efforts have been made to make this document as accurate and helpful as possible, we make no warranty of any kind, expressed or implied, as to the accuracy or completeness of the information contained herein.

The most up-to-date drivers and manuals are available from the Oki web site:

<http://www.okiprintingsolutions.com>

Copyright © 2006 Oki Data Americas, Inc.

Oki and Microline are registered trademarks of Oki Electric Industry Company, Ltd.

ENERGY STAR is a trademark of the United States Environmental Protection Agency.

Microsoft, MS-DOS and Windows are either registered trademarks or trademarks of Microsoft Corporation in the United States and/or other countries.

Other product names and brand names are registered trademarks or trademarks of their proprietors.



As an ENERGY STAR Program Participant, the manufacturer has determined that this product meets the ENERGY STAR guidelines for energy efficiency.



This product complies with the requirements of the Council Directives 89/336/EEC (EMC), 73/23/EEC (LVD) and 1999/5/EC (R&TTE), as amended where applicable, on the approximation of the laws of the member states relating to Electromagnetic Compatibility, Low Voltage and Radio & Telecommunications Terminal Equipment.



**Important safety warnings follow.**

**Be sure to read and observe all safety warnings in this User's Guide.**

# Contents

<b>Preface</b> .....	<b>2</b>
<b>Introduction</b> .....	<b>9</b>
Features .....	9
About this guide .....	10
Online usage .....	11
Printing pages .....	12
<b>MFP Overview</b> .....	<b>13</b>
Identifying system units .....	13
Opening and closing the printer unit top cover . . . .	14
Identifying major components .....	17
Printer unit .....	17
Scanner unit .....	23
Software supplied .....	25
Printer unit .....	25
Paper recommendations .....	25
Paper input and output information .....	26
Trays and stackers .....	27
Tray and stacker examples .....	29
Using the stackers .....	34
Scanner unit .....	36
Paper recommendations .....	36
Loading the document glass (flatbed) . . . . .	38
<b>Control panels</b> .....	<b>39</b>
Printer unit control panel .....	39
Buttons and lights .....	40
Display Panel messages .....	41
Status information .....	41
Menu (Functions) information .....	42
Configuration information .....	42
Help mode .....	43
Display Panel messages .....	43
Using the menus .....	43
Scanner unit control panel .....	44
<b>Getting started</b> .....	<b>47</b>

Turning Off/On . . . . .	47
Turning Off . . . . .	47
Turning On . . . . .	49
Checking current settings . . . . .	50
Interfaces and connection . . . . .	50
Connecting the parallel interface . . . . .	51
Connecting the USB interface . . . . .	52
Connecting the network interface . . . . .	52
Using the Drivers CD . . . . .	54
<b>Printing . . . . .</b>	<b>55</b>
<b>Scanner unit operating information . . . . .</b>	<b>56</b>
Access control . . . . .	56
Logging in . . . . .	56
Logging out . . . . .	57
Status monitoring . . . . .	58
Using the Help facility . . . . .	59
Avoiding incompatibility situations . . . . .	60
<b>Copying . . . . .</b>	<b>61</b>
Basic Settings tab . . . . .	62
Details tab . . . . .	64
Image Quality tab . . . . .	66
Finishing tab . . . . .	68
<b>Scanning . . . . .</b>	<b>69</b>
E-mail send mode . . . . .	69
Confirming e-mail transmission . . . . .	79
Network send mode – scan to FTP . . . . .	79
Confirming FTP transmission . . . . .	86
Remote scan mode . . . . .	87
Mailbox send mode . . . . .	88
<b>Consumables and maintenance – printer unit . . . . .</b>	<b>100</b>
Checking consumable/maintenance item usage . . . . .	100
Replacement indications . . . . .	100
Consumable item order information . . . . .	101
Maintenance item order details . . . . .	101
Replacing consumables/maintenance items . . . . .	102

Cleaning the LED heads . . . . .	102
Cleaning the paper feed rollers . . . . .	106
Cleaning the printer unit casing . . . . .	110
Emptying the punch chip box (Punch unit optional accessory) . . . . .	111
<b>Maintenance – scanner unit . . . . .</b>	<b>114</b>
Cleaning the ADF . . . . .	114
Cleaning the Touch Screen Display . . . . .	116
Cleaning the document glass . . . . .	117
Replacing the snap-in pad module . . . . .	118
Removing the snap-in pad module . . . . .	118
Inserting a new snap-in pad module. . . . .	119
<b>Optional accessories . . . . .</b>	<b>121</b>
Accessory order information. . . . .	121
Installing accessories . . . . .	121
<b>Troubleshooting . . . . .</b>	<b>122</b>
General . . . . .	122
Networking . . . . .	122
Paper jams . . . . .	122
Paper jams – printer unit. . . . .	122
Open cover, paper jam, side cover. . . . .	125
Open cover, paper jam, top cover . . . . .	127
Paper jams – duplex unit. . . . .	135
Check duplex unit, paper jam . . . . .	135
Paper jams – Finisher (optional accessory) . . . . .	140
Check Finisher, paper jam/paper remains . . . . .	140
591, 592, 593, 599/ 643, 645 (paper jam around Finisher) . . . . .	140
594, 597, 598/ 644, 646 (paper jam in Finisher)	143
590 (paper jam in Finisher/Punch unit). . . . .	148
Check Inverter, paper jam . . . . .	150
Avoiding printer unit paper jams . . . . .	156
Dealing with unsatisfactory printing . . . . .	157
Paper jams – ADF. . . . .	159
Dealing with unsatisfactory copying results . . . . .	159
Staple jams – Finisher (optional accessory) . . . . .	160

Check Finisher, Staple Jam . . . . .	160
<b>Specifications . . . . .</b>	<b>165</b>
Printer unit . . . . .	165
Scanner unit . . . . .	166
<b>Appendix A – Display Panel Messages (Printer unit). . . . .</b>	<b>167</b>
<b>Appendix B – Menu system (Printer unit). . . . .</b>	<b>169</b>
Configuration . . . . .	170
Print Page Count . . . . .	170
Finisher Count . . . . .	170
Supplies Life . . . . .	170
Network . . . . .	171
Paper Size in Tray . . . . .	172
System . . . . .	172
Configuration example – monochrome pages printed. . . . .	173
Print Pages . . . . .	174
Print Information example – demonstration page. . . . .	175
Print Secure Job . . . . .	176
Menus . . . . .	176
Tray Configuration . . . . .	176
System Adjust . . . . .	181
Menus example 1 – Tray 1 transparencies. . . . .	184
Menus example 2 – MP Tray paper size. . . . .	186
<b>Appendix C – Scanner Unit Status . . . . .</b>	<b>187</b>
<b>Appendix D – Media support information . . . . .</b>	<b>188</b>
Input locations . . . . .	190
Printer unit output locations. . . . .	192
Finisher unit output locations . . . . .	194
<b>Appendix E – Auto detection paper sizes . . . . .</b>	<b>196</b>
Flatbed (document glass) . . . . .	196
ADF . . . . .	197
<b>Appendix F – Scanner unit setup details. . . . .</b>	<b>198</b>
Setting up address books . . . . .	198

Setting up mailboxes . . . . .	199
Setting up machine parameters . . . . .	199
Setting up copying parameters . . . . .	199
Setting up scan properties . . . . .	200
Administrator setup . . . . .	201
Generating reports . . . . .	203
Scanner unit counter readings . . . . .	204
Setup complete . . . . .	204
<b>Appendix G– Troubleshooting (network) . . . . .</b>	<b>205</b>
Cannot send e-mail. . . . .	205
Cannot search on LDAP server . . . . .	205
<b>Appendix H – Touch screen setup . . . . .</b>	<b>207</b>
<b>Index . . . . .</b>	<b>209</b>



# Introduction

Congratulations on buying an Oki multifunction product (MFP) which can be used for:

- > local printing
- > network printing
- > copying
- > network scanning

The MFP models described in this user's guide are:

- > ES3640e MFP
- > ES3640e MFP GA

where GA denotes Graphic Arts capability.

## Features

- > space-saving, integrated multifunction system
- > easy-to-use control panels
- > high speed printing, copying and scanning
- > EFI Fiery print control and job management software
- > Graphic Arts capability with full suite of EFI utilities including Spot-On and Hot Folder support (ES3640e MFP GA only)

Additionally, the following optional accessories are available:

- > Finisher for stapling or saddle stitching printer output
- > Punch unit (to extend Finisher functionality)
- > EFI Color Profiler Kit

## About this guide

### NOTE

*Images used in this manual may include optional features that your printer does not have installed. Also, they may omit features not essential to the description of a particular function.*

This manual is your user's guide (check the web site, [my.okidata.com](http://my.okidata.com), for the most up-to-date version) for your printer and forms part of the overall user support listed below:

- > **Software Utilities guide:** to provide an overview of drivers and utilities provided

This is an electronic document stored on the Documentation CD.

- > This **User's Guide:** to help you to become familiar with your MFP and make the best use of its many features. Also included are guidelines for troubleshooting and maintenance to ensure that it performs at its best. Additionally, information is provided for adding optional accessories as your needs evolve.

This is an electronic document stored on the Documentation CD.

- > **Printing Guide** for Windows users and Mac users: to help you operate your printer unit effectively and efficiently as a network printer

This is an electronic document stored on the Documentation CD.

- > **Configuration Guide:** to provide machine configuration and network configuration information

This is an electronic document stored on the Documentation CD.

- > **EFI Fiery documentation suite**

These are electronic documents stored on the EFI Utilities CD.

- > **Installation Guides:** accompany consumable items and optional accessories to describe how to install them

These are paper documents that are packaged with the consumables and optional accessories.

- > **Online Help:** online information accessible from the control panels, printer driver and utility software

## Online usage

This guide is intended to be read on screen using an Adobe Acrobat Reader. Use the navigation and viewing tools provided in Acrobat.

You can access specific information in two ways:

- > In the list of bookmarks down the left hand side of your screen, click on the topic of interest to jump to the required topic. (If the bookmarks are not available, use the ["Contents" on page 15.](#))
- > In the list of bookmarks, click on Index to jump to the Index. (If the bookmarks are not available, use the ["Contents" on page 15.](#)) Find the term of interest in the alphabetically arranged index and click on the associated page number to jump to the page containing the term.

## Printing pages

The whole manual, individual pages, or sections may be printed. The procedure is:

1. From the toolbar, select [File], then [Print] (or press the Ctrl + P keys).
2. Choose which pages you wish to print:
  - (a) [All pages], (1), for the entire manual.
  - (b) [Current page], (2), for the page at which you are looking.

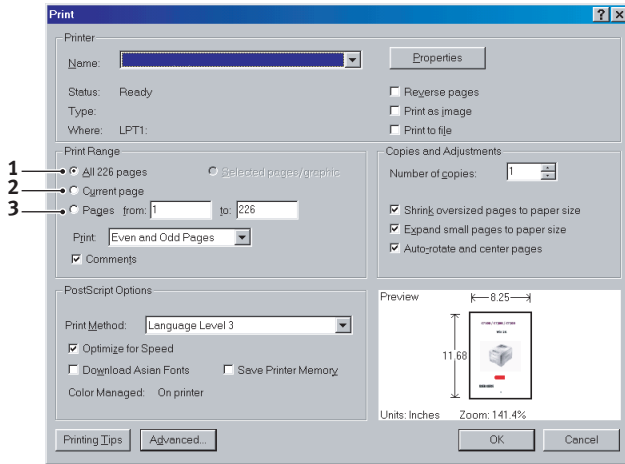

- (c) [Pages from] and [to], (3), for the range of pages you specify by entering their page numbers.



3. Click on [OK].

# MFP Overview

## Identifying system units

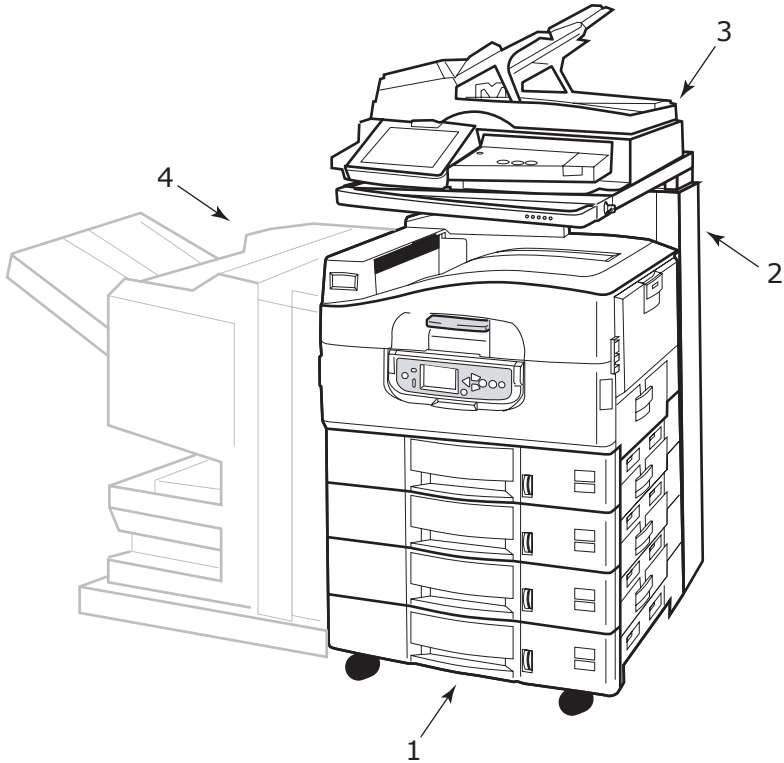

1. Printer unit (with high capacity feeder (HCF))
2. Scanner stand
3. Scanner unit
4. Finisher unit (optional accessory)

## Opening and closing the printer unit top cover



*The stand includes hydraulics for moving the scanner shelf up and down. Use extreme caution.*

**NEVER ATTEMPT TO RAISE OR LOWER THE SHELF WITHOUT THE SCANNER BOLTED TO IT. WITHOUT THE WEIGHT OF THE SCANNER ON IT, THE SHELF COULD RISE RAPIDLY WHEN RELEASED, POTENTIALLY CAUSING SEVERE INJURY.**

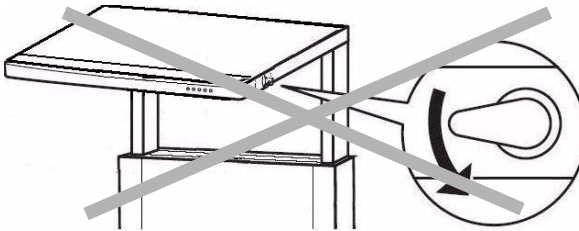

1. Place one hand firmly on the front handle (1) of the scanner shelf, then carefully press the release handle (2) so that the shelf lifts out of the way.

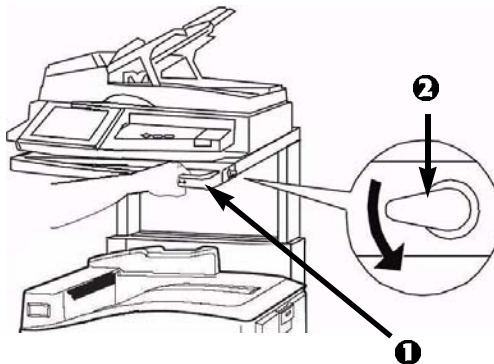

2. To open the top cover, squeeze the top cover handle (1) to release the catch and raise the cover.

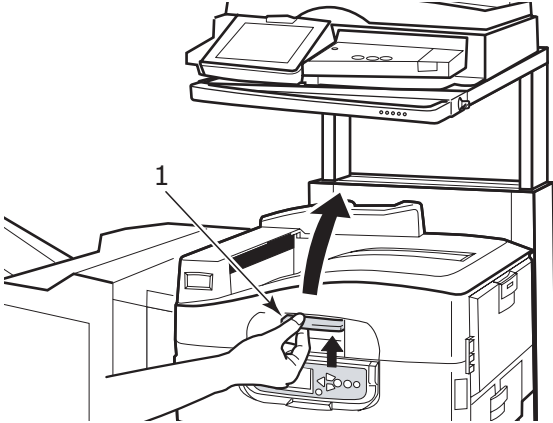

3. To close the top cover, push gently (1) until the cover stops midway and then push harder (2) to close the cover completely. Ensure that the cover is securely closed.

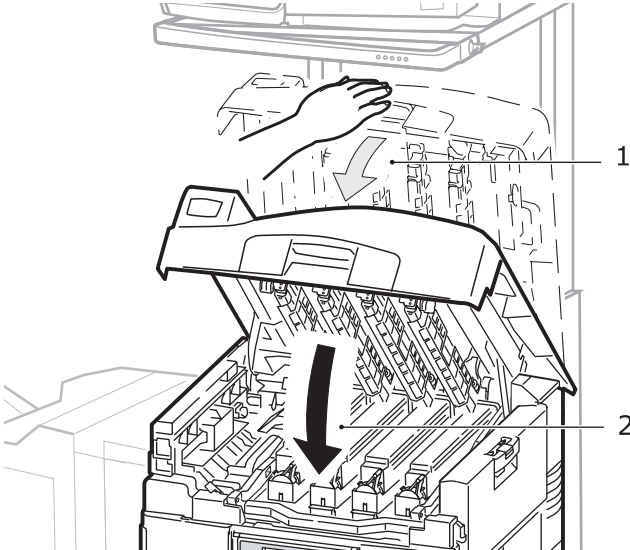

**TO PREVENT ANY POSSIBLE CRUSHING OF FINGERS, KEEP YOUR HANDS AWAY FROM THE POSTS AT THE BACK OF THE SCANNER STAND WHEN MOVING THE SCANNER SHELF DOWN.**

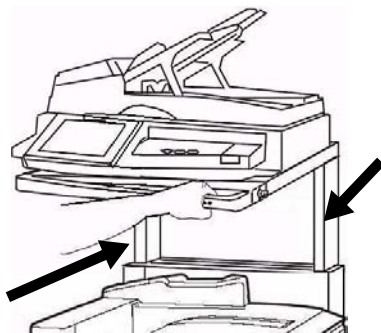

4. Place one hand firmly on the front handle of the scanner shelf, then press the release handle and carefully lower the scanner shelf, making sure it locks in place.

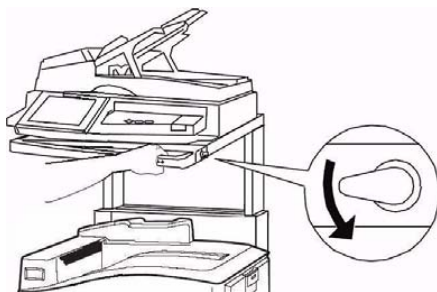



## Identifying major components

### Printer unit

The major components of your printer unit are identified in the graphics below.

1. Paper holding arm
2. Top cover (face-down stacker)
3. MP Tray (multi-purpose tray)
4. Tray 1 side cover
5. Paper size label
6. Paper gauge
7. Tray 1 (paper tray)
8. Control panel
9. Top cover handle

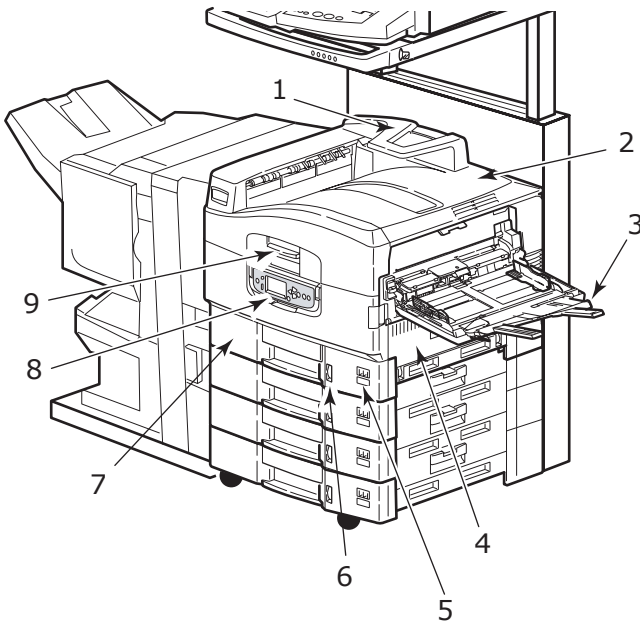

10. Face-down stacker

**11.** Power (on/off) switch

**12.** Face-up stacker

**13.** Duplex unit

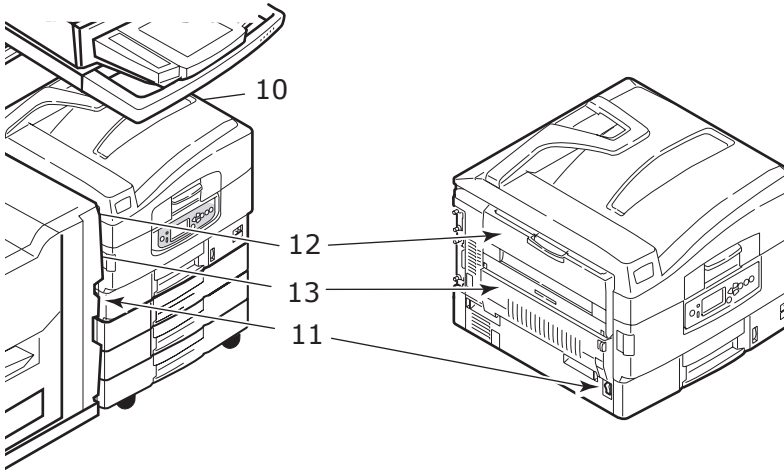

**14.** Interface unit

- 15. Network interface connector
- 16. Parallel interface connector
- 17. USB interface connector

*NOTE*

*The three connectors at 17a are for printer unit to scanner unit interconnection.*

- 18. Power connector
- 19. Ventilation openings

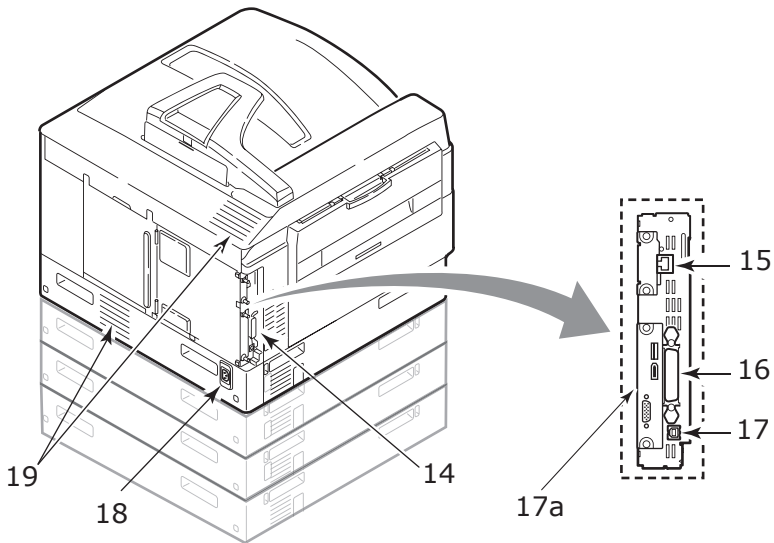

- 20. Image drum cartridge and toner cartridge (Cyan)

- 21. Image drum cartridge and toner cartridge (Magenta)
- 22. Image drum cartridge and toner cartridge (Yellow)
- 23. Image drum cartridge and toner cartridge (Black)
- 24. Toner cartridge
- 25. Image drum cartridge
- 26. Fuser unit
- 27. LED heads

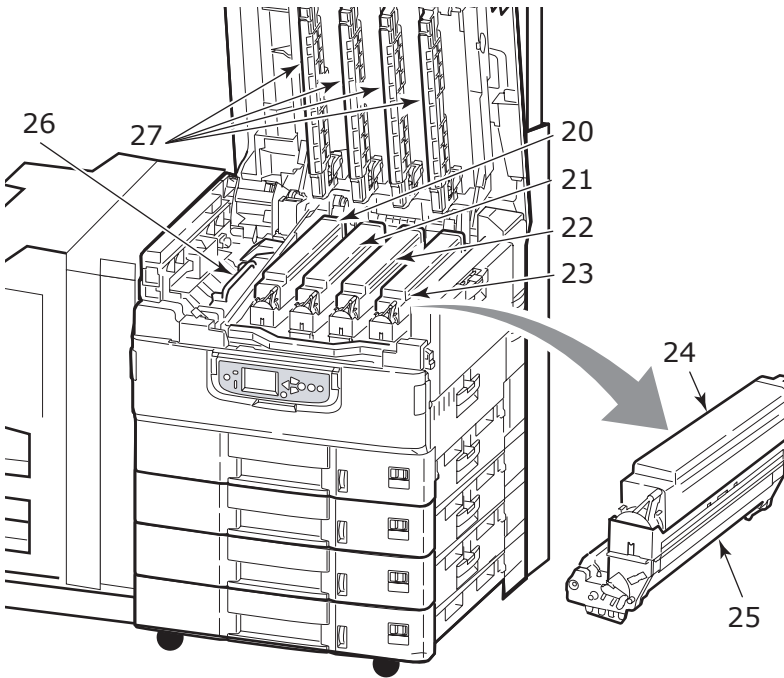

- 28. Belt unit

**29.** Drum basket handle

**30.** Drum basket

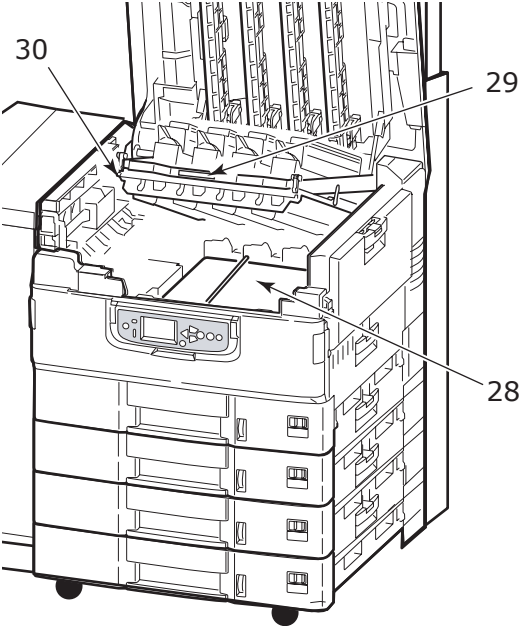

**31.** High capacity Feeder (HCF) 3 trays

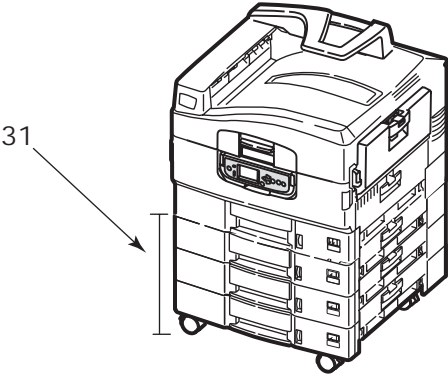

## Scanner unit

The major components of your scanner unit are identified in the graphics below.

### Front view

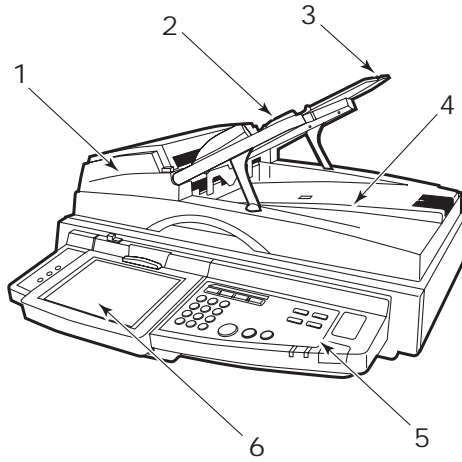

1. Automatic document feeder (ADF) front cover
2. ADF paper tray
3. ADF paper support
4. Document cover
5. Control panel
6. Touch screen display

## Back view

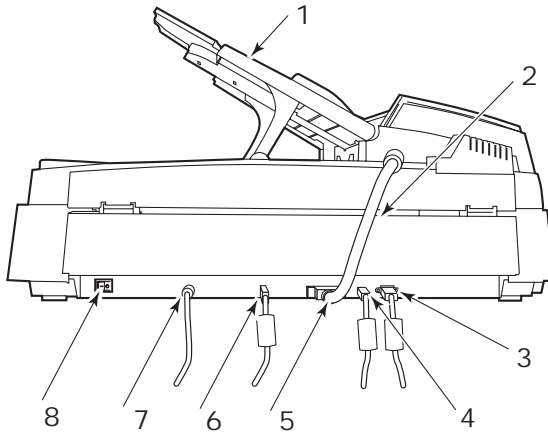

- 1.** ADF paper tray, for multi-page documents
- 2.** ADF cable, to connect the ADF to the main unit
- 3.** Display port, to connect to printer unit
- 4.** Control port, to connect to printer unit
- 5.** ADF port, to connect the ADF cable
- 6.** Data port, to connect to printer unit
- 7.** Power jack, to connect to a power source
- 8.** Power switch, to turn the scanner on/off



## Software supplied

CDs:

- > Drivers  
Contains PCL and PS drivers, utilities and productivity software for the PCL driver.
- > Documentation  
Contains documentation in electronic form to describe how to use the printer for day-to-day tasks.
- > EFI Utilities  
Contains all the EFI utility software.

## Printer unit

### Paper recommendations

Your printer unit will handle a variety of print media, including a range of paper weights and sizes, transparencies and envelopes. This section provides general advice on choice of media, and explains how to use each type.

The best performance will be obtained when using standard weight 20 – 24 lb (75 – 90 g/m<sup>2</sup>) paper designed for use in copiers and laser printers. Suitable types are:

- > OKI® Bright White, 32 lb US Bond
- > HammerMill® Laser Print Radiant, White, 24 lb US Bond
- > Xerox® 4024, 20lb US Bond

Use of heavily embossed or very rough textured paper is not recommended.

**Pre-printed stationery** can be used, but the ink must not offset when exposed to the high fuser temperatures used in the printing process.

**Envelopes** should be free from twist, curl or other deformations. They should also be of the rectangular flap type, with glue that remains intact when subjected to hot roll pressure fusing used in this type of printer. Window envelopes are not suitable.

**Transparencies** should be of the type designed for use in copiers and laser printers. In particular, avoid office

transparencies designed for use by hand with marker pens. These will melt in the fuser and cause damage.

**Labels** should also be of the type recommended for use in copiers and laser printers, in which the base carrier page is entirely covered by labels. Other types of label stock may damage the printer due to the labels peeling off during the printing process. Suitable types are:

- > Avery White Laser Label types 7162, 7664, 7666 (A4), or 5161 (Letter)

## Paper input and output information

The following table relates paper parameters to input trays (Tray 1 to Tray 4 (numbering from the top) and MP Tray) and to output areas (Face-down stacker and Face-up stacker).

Type	Size	Weight	input/output
Plain paper	A3, A3 Nobi, A3 Wide, A4, A5, A6, B4, B5, Letter, Legal 13, Legal 13.5, Legal 14, Executive, Tabloid, Tabloid Extra	17 – 57 lb	Any Tray Any Stacker
	Custom W: 3.94 – 12.91 in L: 5.82 – 18 in	17 – 57 lb	Any Tray Face-up Stacker
	Custom W: 3.12 – 12.91 in L: 3.54 – 18 in	17 – 71 lb	MP Tray Face-up Stacker
	Banner W: Letter width L: 18 – 48 in	34 lb recommended	MP Tray Face-up Stacker
	Index card: 3 x 5 in	17 – 71 lb	MP Tray Face-up Stacker
Postcard	–	–	Tray 1 or MP Tray Face-up Stacker

Type	Size	Weight	input/output
Envelope	4.72 x 9.25 in 3.54 x 8.07 in 9.25 x 4.72 in 9.25 x 4.13 in 9.45 x 13.07 in 8.50 x 10.91 in 4.69 x 7.76 in 8.27 x 11.69 in	23 lb	MP Tray Face-up Stacker
	12.76 x 9.02 in 9.02 x 6.38 in 8.66 x 4.33 in 8.88 x 3.88 in 9.5 x 4.13 in 7.5 x 3.88 in	Based on 24 lb paper	
Labels	A4, Letter, B5	0.004 – 0.008 in	MP Tray Face-up Stacker
Transparencies Glossy paper	A4, Letter	0.004 in	Tray 1 or MP Tray Face-up Stacker

## Trays and stackers

### Trays 1 to 4

Tray 1 is the standard blank paper input tray and can hold up to 530 sheets of 20 lb (75 g/m<sup>2</sup>) paper. Trays 2 to 4 result in a total tray capacity of 2120 sheets of 20 lb (75 g/m<sup>2</sup>) paper.

If you have identical paper stock loaded in another tray (for example Tray 2 or the MP Tray), you can have the printer automatically switch to that other tray when the current tray runs out of paper. This function can be enabled by driver settings when printing from a Windows application or by a menu setting when printing from other applications.

### MP Tray

The multi-purpose tray is used for media sizes additional to those of the standard trays, heavier media weights and special media.

The multi-purpose tray can handle the same sizes as the standard trays but in weights up to 71.3 lb (268 g/m<sup>2</sup>). For very heavy paper stock use the face-up paper stacker. This ensures that the paper path through the printer is almost straight.

The multi-purpose tray can feed paper widths as small as 3 in (76.2 mm) and lengths up to 47.24 in (1200 mm). For banner printing, recommended sizes are Letter wide, 35.43 in and 47.24 in long and weight 34 lb (128 g/m<sup>2</sup>).

Use the multi-purpose tray for printing on envelopes and transparencies. Up to 100 sheets of transparencies or 25 envelopes can be loaded at one time, subject to a maximum stacking depth of 1 in.

Paper or transparencies should be loaded print side up and top edge into the printer. Do not use the duplex (two-sided printing) function for transparencies.

### **Face-down stacker**

The face-down stacker on the top of the printer can hold up to 500 sheets of 20 lb (80 g/m<sup>2</sup>) standard paper, and can handle paper stocks from 17 – 57 lb (64 – 216 g/m<sup>2</sup>). Pages printed in reading order (page 1 first) will be sorted in reading order (last page on top, facing down).

### **Face-up stacker**

The face-up stacker should be opened and the tray extension pulled out when required for use. (With the face-up stacker either open or closed, the driver setting of Face Down will successfully direct prints to the Face-Down stacker.)

The face-up stacker can hold up to 250 sheets of 20 lb (80 g/m<sup>2</sup>) standard paper and can handle stocks up to 71.3 lb (268 g/m<sup>2</sup>).

Always use this stacker and the multi-purpose feeder for paper stocks heavier than 57 lb (216 g/m<sup>2</sup>).

### **Duplex unit**

This unit provides automatic two-sided printing on plain paper fed from Trays 1 – 4 or the MP Tray. Applicable paper sizes are A6, A5, B5, B5LEF, Executive, A4, A4LEF, Letter, LetterLEF, Legal 13 in, Legal 13.5 in, Legal 14 in, B4, Tabloid, Tabloid Extra, A3, A3 Wide, A3 Nobi, Custom size (3.9 – 12.9 in wide, 5.8 – 18 in long), using paper stocks in the range 20 – 32 lb (75 – 120 g/m<sup>2</sup>).

## Tray and stacker examples

### Loading Trays 1 to 4

Tray 1 is used in the following example.

1. Pull out the tray.
2. Press the paper rear stopper tab (1) and adjust the tab to the required paper size.

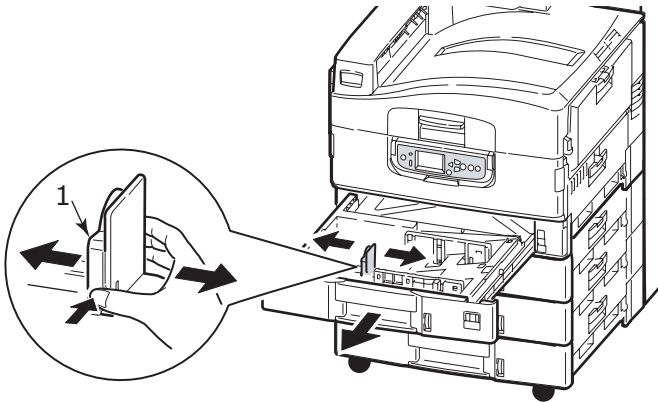

3. Fan the paper to be loaded then tap the edges of the stack on a flat surface to make it flush.

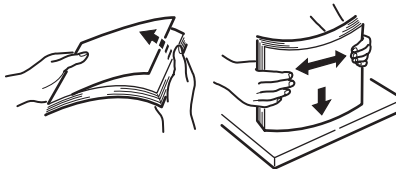

4. Load the paper (face down and top edge towards the right for letterhead paper), press the tab (2) on the paper guide and adjust the guides (3) for a snug fit to the paper.

To avoid paper jams:

- > Do not leave space between the paper and the guides and rear stopper.
- > Do not overfill the paper tray. Capacity depends on the paper type.
- > Do not load damaged paper.
- > Do not load paper of different sizes or types at the same time.

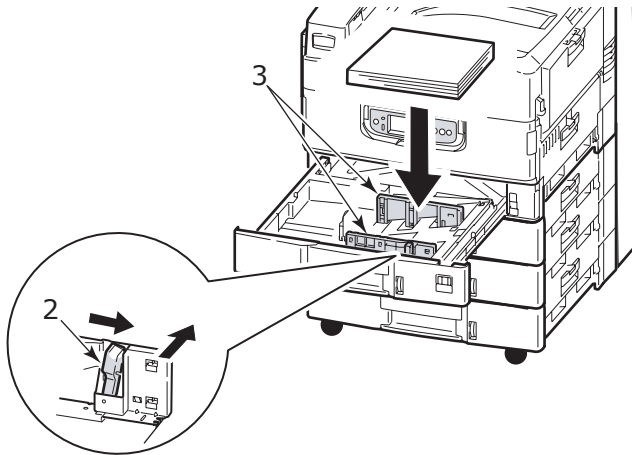

**5.** Gently push the tray back into the printer.

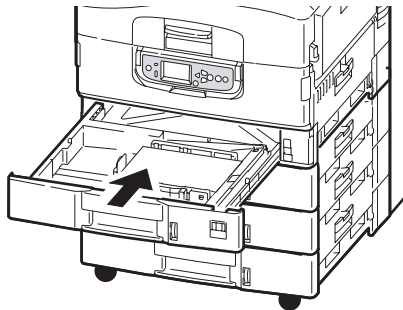

## Using the MP Tray

1. Squeeze the handle (1) and open the multi-purpose tray.

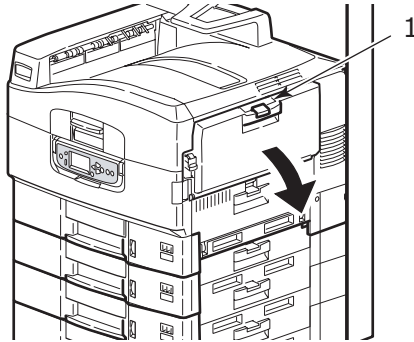

2. Fold out the paper support section and swivel out the extension supports (2).

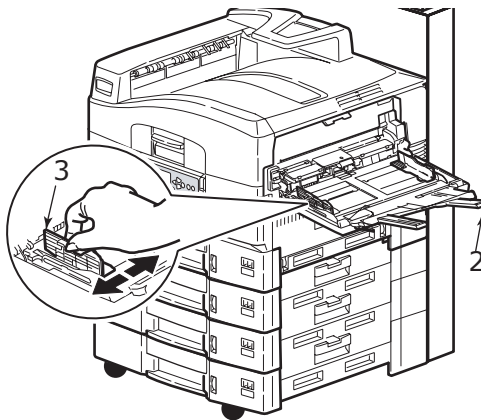

3. Adjust the paper guides (3) to the size of the paper being used.

4. Fan the paper to be loaded then tap the edges of the stack on a flat surface to make it flush.

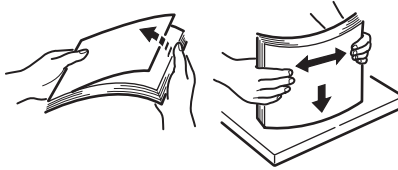

5. Load the paper.
  - > For single-sided printing on letterhead, load the paper into the multi-purpose tray with pre-printed side up and top edge into the printer unit.
  - > For two-sided (duplex) printing on letterhead, load the paper with pre-printed side down and top edge away from the printer unit.
  - > Envelopes should be loaded face-up with long edge into the printer. Do not select duplex printing on envelopes.
  - > Do not leave space between the paper and the guides.



- > Do not exceed the paper capacity of approximately 230 sheets, 100 transparencies or 25 envelopes. Maximum stacking depth is 1in.

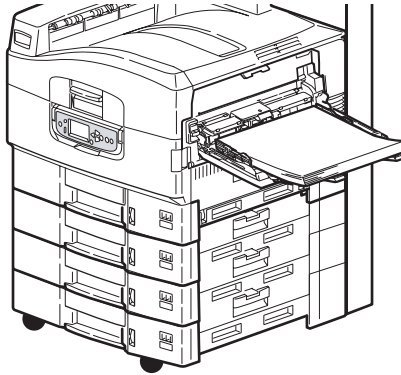

## Using the stackers

### Face-down stacker

When the face-up stacker (1) on the left side of the printer is closed (its normal position), paper is ejected to the face-down stacker on the top of the printer unit.

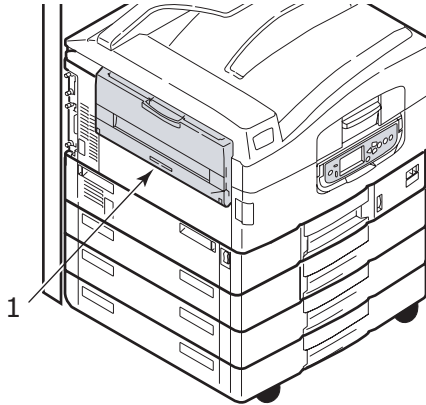

### Face-up stacker

The face-up exit path is used for heavy paper (cardstock etc.), envelopes, transparencies, and labels.

1. Open the stacker (1).

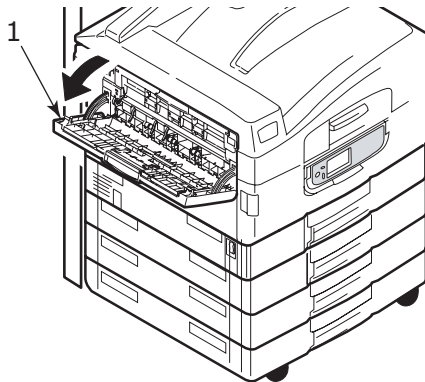

2. Flip out the paper support (2).

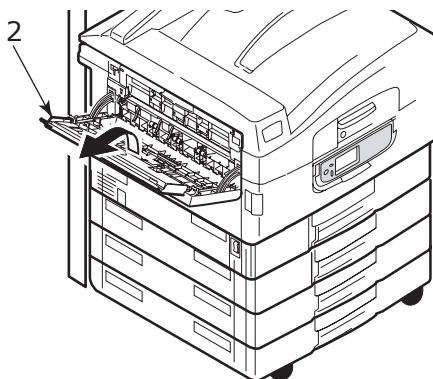

3. Swivel out the paper support extension (3).

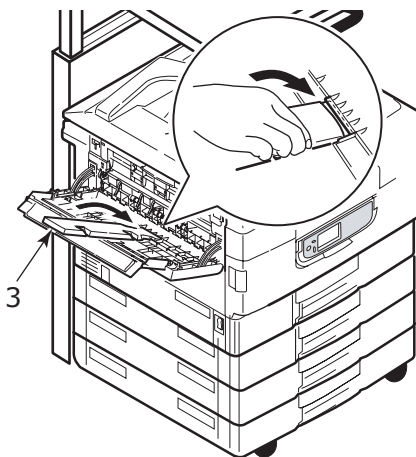

## Scanner unit

### Paper recommendations

The ADF can handle up to 50 sheets of 11.8 in x 17 in paper, of weight 16 – 28 lb (60 – 105 g/m<sup>2</sup>).

The glass can handle paper sizes up to 11.8 in x 17 in and the document cover can be left open to accommodate book thickness.

Use the glass and not the ADF for scanning documents that:

- have a smooth surface e.g. photographic, coated or glossy paper
- are folded, creased, curled or otherwise deformed
- are not rectangular
- have labels attached or have other surface unevenness
- are less than 100mm in width or less than 180mm in length. Such documents may cause feed errors or skew in the ADF.

### Loading the ADF

For documents of size Letter, the following orientation is recommended:

- > Copy Mode: document face up, top of the document away from the user
  - > Scan to E-Mail, Scan to FTP, Scan to Mailbox, Scan to Hold Queue, Remote Tool: document face up, top of document to left of user
1. Ensure your document is free of staples and clips and has no ragged edges.
  2. If you are loading multiple pages (up to a maximum of 50), fan the pages to avoid potential paper jams then tap the edges of the stack on a flat surface to make it flush.

3. With the text face up, introduce the document far enough into the ADF to be able to adjust the paper guide (1) to center the document in the ADF.

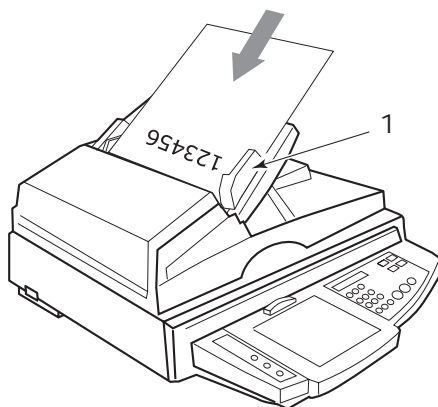

4. Release the document gently into the ADF.

## Loading the document glass (flatbed)

For documents of size Letter, the following orientation is recommended:

- > Copy Mode: document face down, top of the document toward the user
  - > Scan to E-Mail, Scan to FTP, Scan to Mailbox, Scan to Hold Queue, Remote Tool: document face down, top of document to left of user
1. Open the document cover to reveal the glass.
  2. Place your document with text face down on the glass, aligning it to the upper left corner of the glass.

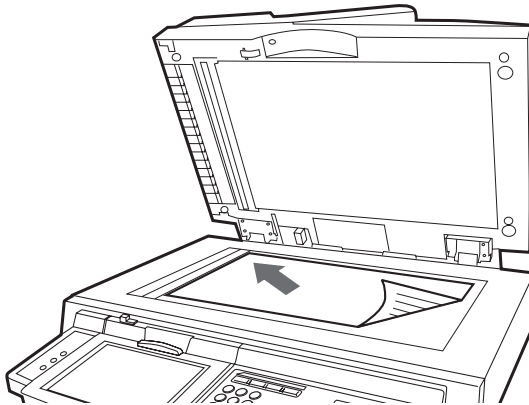

3. Close the document cover.

# Control panels

Control of your MFP is via two control panels, one located on the printer unit and the other on the scanner unit. The two control panels are complementary to each other and work together as component parts of the overall system. For example, a message on the scanner unit control panel will redirect you to the printer control panel if the situation requires it.

## Printer unit control panel

The control panel can be swivelled to 90° (maximum) upwards from its base position (1) as required for ease of use.

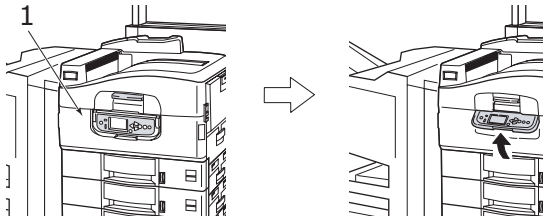

## Buttons and lights

The parts of the control panel are identified and briefly explained below:



### 1. Shutdown/Restart button

Press and hold down for a soft shutdown. You can then press this button again for a restart or use the **Power** switch to turn off the printer completely.

### 2. Ready light

On: indicates ready to print

Flashing: indicates processing print data

Off: indicates unable to receive data (offline)

### 3. Attention light

Off: indicates normal operation

Flashing: indicates error(s) present but printing can continue

On: indicates error(s) present and printing cannot continue

### 4. Display panel

Displays status and setup information for the printer and user help information in your chosen language

### 5. Up-arrow button

Enters menu mode and enables upward movement through the displayed list of menu items



**6. Down-arrow button**

Enters menu mode and enables downward movement through the displayed list of menu items

**7. Back button**

Returns to the previous higher level menu item

**8. Enter button**

Enters menu mode and selects the menu item highlighted in the display panel

**9. Online button**

Switches between online (printer unit ready to receive data) and offline (printer unit not ready to receive data)

**10. Cancel button**

Cancels current print job

**11. Help button**

Provides additional textual or image data to supplement what is displayed on the display panel

## Display Panel messages

There are four types of display panel message:

- > Status information
- > Menu (functions) information
- > Configuration information
- > Help information

## Status information

Status information is associated with three printer unit states:

In the Information state, such as idling or printing, the printer unit is able to process print jobs.

In the Warning state, the printer unit has encountered some minor problem but is still able to process print jobs.

In the Error state, the printer unit has encountered a problem and cannot continue printing until the user has intervened and removed the cause of the trouble.

The top two lines of the display panel show the printer unit status. The bottom of the display panel normally shows a bar chart of the toner usage.

## Menu (Functions) information

There are three types of menu (functions) information:

User menus: accessed by pressing the **Enter** button, **Up-arrow** or **Down-arrow** button on the control panel. These menus are available to the general user to make various settings that are used in the running of the printer unit.

Administrator menu: accessed by pressing the **Enter** button for more than 2 seconds while turning on the printer power supply (including Restart). Available to administrator level users. Restricts the changes that general users can make via the user menus.

System maintenance menu: accessed by pressing the **Up-arrow** and **Down-arrow** buttons together for more than 2 seconds while turning on the printer unit power supply (including Restart). Available to support staff to allow printer unit configurations and special functions to be set.

## Configuration information

Configuration information displays printer unit configuration information such as internal firmware versions.

Menu options at each level can be scrolled through by moving the highlight with the **Up-arrow/Down-arrow** buttons and a highlighted option at that level can be selected by pressing the **Enter** button. When the lowest level menu has been selected, you can change the setting for that menu by selecting the required highlighted value from a list or by entering a numeric value. In other cases, you can display or print configuration information.

## Help mode

When an error has occurred, press the **Help** button. Information displays that will help you correct the error.

## Display Panel messages

The display panel messages, supplemented by the Help messages where appropriate, are intended to be self-explanatory. More information on typical messages is provided in ["Appendix A – Display Panel Messages \(Printer unit\)" on page 167](#).

## Using the menus

### *NOTE*

*Menu details are given in ["Appendix B – Menu system \(Printer unit\)" on page 169](#) for reference.*

The **Enter**, **Up-arrow**, **Down-arrow** and **Back** buttons are used to move through the printer menus. You can adjust settings (e.g. set the paper size for Tray 1) or view information (e.g. how much is left of a selected consumable).

Many of these menu settings can be, and often are, overridden by settings in the Windows printer drivers. However, several of the driver settings can be left at "Printer Setting," which will then default to the settings entered in these printer menus.

The steps involved in using the menus are typically as follows:

1. Ensure that the display panel indicates that the printer unit is ready to print.
2. Enter User menu mode by pressing either the **Enter** button or the **Up-arrow** or **Down-arrow** button and press the latter two repeatedly until the desired menu is highlighted in the displayed list.
3. Press the **Enter** button to select this menu.
4. Press the **Up-arrow** or **Down-arrow** buttons repeatedly until the desired Item is highlighted.
5. Press the **Enter** button to select this Item.
6. Press the **Up-arrow** or **Down-arrow** buttons repeatedly until the desired Value is highlighted.

7. Press the **Enter** button to select this Value. (If you are setting a parameter, ensure that an asterisk (\*) appears beside the selected parameter Value.)
8. Press the **Online** button to exit menu mode and return to the ready to print status.

Refer to the section entitled ["Getting started" on page 47](#) and ["Appendix B – Menu system \(Printer unit\)" on page 169](#) for examples of using the menus.

## Scanner unit control panel

The parts of the control panel are identified and briefly explained below:

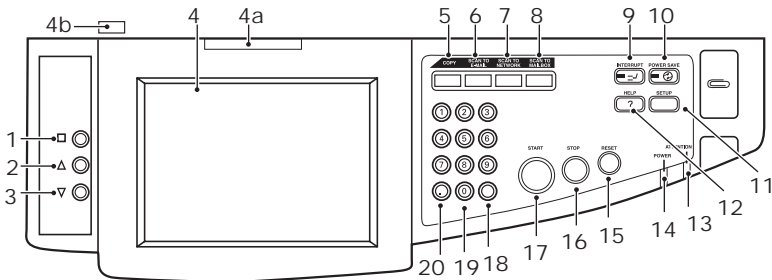

### 1. Menu button

Starts/ends an LCD image adjustment feature OSD menu to adjust brightness, contrast, image position etc. For further details, refer to ["Appendix H – Touch screen setup" on page 207](#).

### 2. Up-arrow button

Lets you step through the LCD image features until a required feature is reached. When the feature is selected by pressing the Menu button, this button enables you to increment the value of the feature. Pressing the Menu button confirms and sets the new value.

### 3. Down-arrow button

Lets you step through the LCD image features until a required feature is reached. When the feature is selected by pressing the Menu button, this button enables you to

decrement the value of the feature. Pressing the Menu button confirms and sets the new value.

**4. Touch screen display**

Enables you to make selections associated with the copying and scanning functions by touching the screen to press selected buttons. The screen can be tilted up for ease of viewing by pulling on handle (4a) and it locks in position. Use the release control (4b) to enable downward adjustments.

Be careful not to scratch the display with sharp or pointed objects e.g. a ballpoint pen as this may impair the display.

**5. COPY button**

Pressing this button selects copy mode on the touch screen.

**6. SCAN TO E-MAIL button**

Pressing this button selects e-mail send mode on the touch screen.

**7. SCAN TO NETWORK button**

Pressing this button selects network send mode on the touch screen for scan to FTP and remote scan functions.

**8. SCAN TO MAILBOX button**

Pressing this button selects mailbox send mode on the touch screen for scanning to a mailbox or to a hold queue.

**9. INTERRUPT button**

Pressing this button switches interrupt mode on or off, its LED being illuminated when interrupt mode is on. Use this button to interrupt a print job and carry out a scan.

**10. POWER SAVE button**

Pressing this button switches the scanner unit power save mode on or off, its LED being illuminated when power save mode is on.

**11. SETUP button**

Pressing this button selects setup mode for address books or reports, for example. (See ["Appendix F – Scanner unit setup details" on page 198.](#))

**12. HELP button**

Pressing this button displays help information on the touch screen.

**13. ATTENTION light**

Flashes when operator attention is required e.g after a paper jam has occurred.

**14. POWER light**

Is illuminated when the scanner unit is on.

**15. RESET button**

Pressing this button returns all settings of a selected function to their default values, but does not stop jobs in progress.

**16. STOP button**

Pressing this button stops the scanning process.

**17. START button**

Pressing this button starts the scanning process.

**18. Clear button**

Pressing this button clears all text in a selected text box on the touch panel.

**19. Numeric buttons (0 – 9)**

Use these buttons to enter number of copies, e-mail address, scale of copy for example.

**20. Period button**

Use this button to enter decimal values or in e-mail addresses.

# Getting started

This section provides information to help you get started with using your MFP.

## Turning Off/On

### Turning Off

**1.** Printer unit

Press and hold down the **Shutdown/Restart** button (1) on the control panel to start the shutdown process.

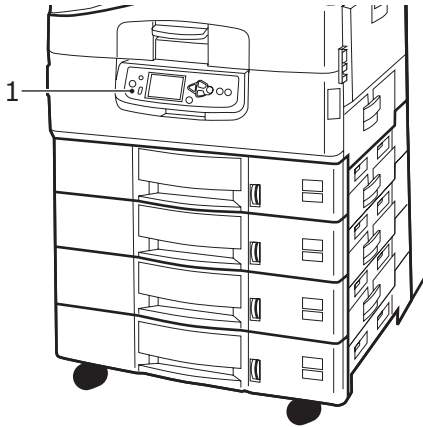

**2.** Scanner unit

When the scanner unit display shows that shut down has been completed, turn off the scanner unit at the power switch (1).

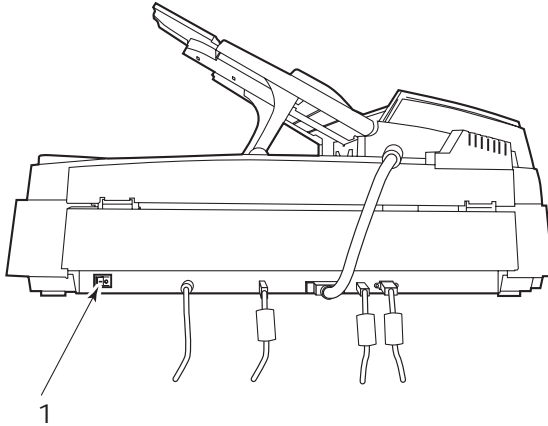

3. Use the On/Off switch to turn off the printer unit. Please wait as this may take a short time.

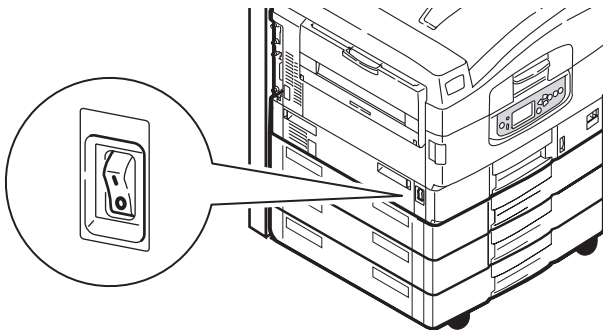



## Turning On

### 1. Scanner unit

Turn on the scanner unit at the power switch (1).

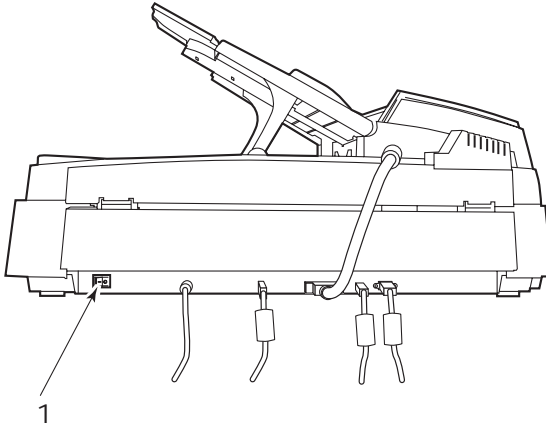

#### NOTE

If the display panel shows that you can either turn off or restart the printer, press **Shutdown/Restart** to turn on the printer.

2. If the printer is turned off (no power), use the On/Off switch to turn on the printer. Please wait as this may take a short time.

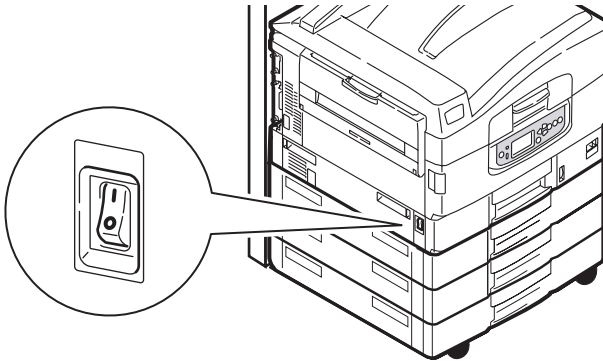

3. Even if you are using your MFP only for printing, please ensure that the scanner unit is turned on.

## Checking current settings

Carry out the following steps to generate a Configuration report (Menu Map) to confirm that your printer unit is correctly configured.

1. Ensure that there is Letter paper in Tray 1 (to be used in this operation).
2. Ensure that the display panel indicates that the printer is ready to print.
3. Press the **Up-arrow** or **Down-arrow** buttons repeatedly until Print Pages is highlighted.
4. Press the **Enter** button to select Print Pages.
5. Press the **Up-arrow** or **Down-arrow** buttons repeatedly until Configuration is highlighted.
6. Press the **Enter** button to select Configuration.
7. Press the Enter button to execute the command and a Configuration document is printed.
8. After printing the configuration document, the printer unit returns to the ready to print status.
9. You can use this document to check your printer unit configuration. System values and installed accessories are listed at the top of the first page while status values and settings follow.

## Interfaces and connection

Your printer unit is equipped with a selection of data interfaces:

- > **Parallel** – For direct connection to a PC. This port requires a bi-directional (IEEE 1284 compliant) parallel cable.
- > **USB** – For connection to a PC running Windows 98 or above (not Windows 95 upgraded to Windows 98) or Macintosh. This port requires a cable conforming to USB version 2.0 or above.

The printer unit may not work if a USB-compatible device is connected concurrently with other USB-compatible machines.

When connecting multiple printer units of the same type, they appear as \*\*\*\*\* (1), \*\*\*\*\* (2), \*\*\*\*\* (3), etc. These numbers depend on the order of connecting or turning on each printer unit.

> **Ethernet** – For network cable connection.

*NOTE*

*Interface cables are not supplied with your printer unit.*

### Connecting the parallel interface

1. Turn off the printer unit and the computer.
2. Connect a parallel cable between the printer unit and computer.

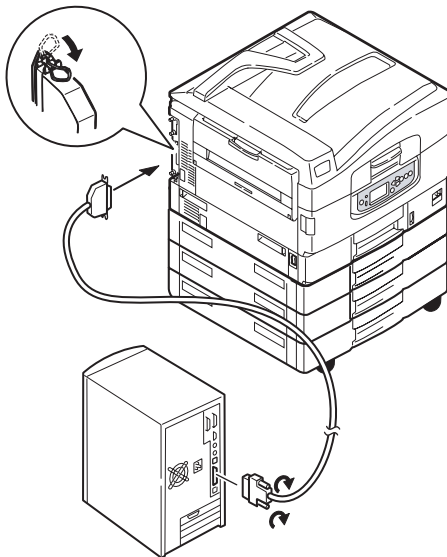

3. Turn on the printer unit and then the computer.

## Connecting the USB interface

Do not connect the USB cable at this time. You will be instructed when to connect the USB cable when you run the Drivers CD.

If you are connecting your printer unit directly to a stand alone computer proceed to the section entitled "Using the Drivers CD".

## Connecting the network interface

1. Turn off the printer unit and the computer.
2. Remove the protective cover from the network connector on the printer unit.

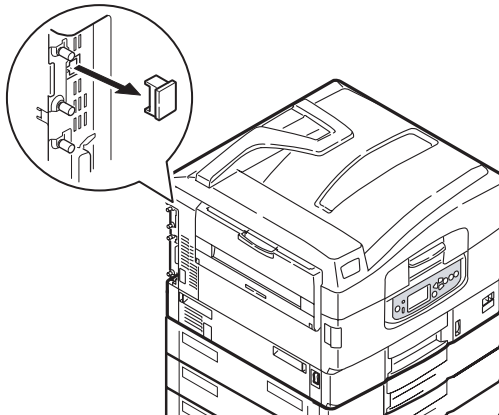

3. Connect an Ethernet cable between the printer unit and an Ethernet hub.

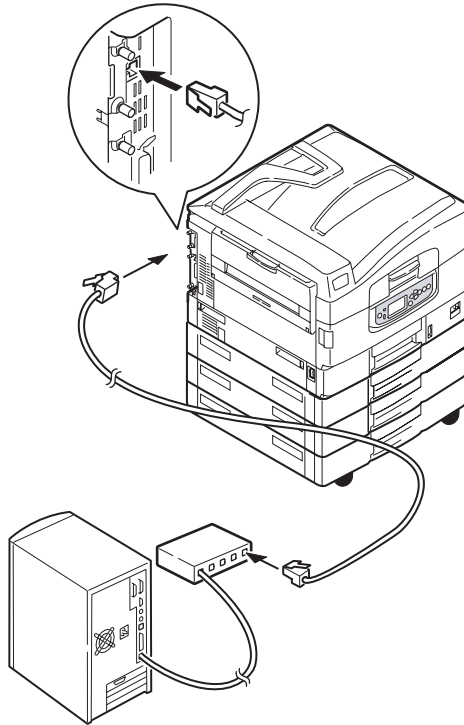

4. Turn on the printer unit and then the computer.

If your printer unit is to be installed as a network printer, please refer to the relevant section in the Software Installation Guide and Configuration Guide for further details on how to configure the network connection before installing the printer drivers.

**NOTE**

*Administrator's authority is required when installing a network connection.*

## **Using the Drivers CD**

For instructions on installing the drivers and other software, refer to the Software Installation booklet.

# Printing

For full details of how to use the printer unit and any optional accessories to print jobs efficiently and effectively, please refer to the Printing Guide.

# Scanner unit operating information

## Access control

If your Administrator has enabled access control on your scanner, it will automatically start up in access control mode. You will not be able to use it until you have provided a valid PIN and logged in. After using it, you will be expected to log out, leaving the scanner unit in access control mode, unable to be used by unauthorised users.

### NOTE

*The PIN is associated with using the Job Accounting Utility and is the last four digits of the ID used for Job Accounting.*

## Logging in

1. At the access control screen, use the numeric keys on the scanner unit to enter your PIN.





2. Press the Login button (1) and the default Copy Mode screen appears, the scanner unit now being available to use.

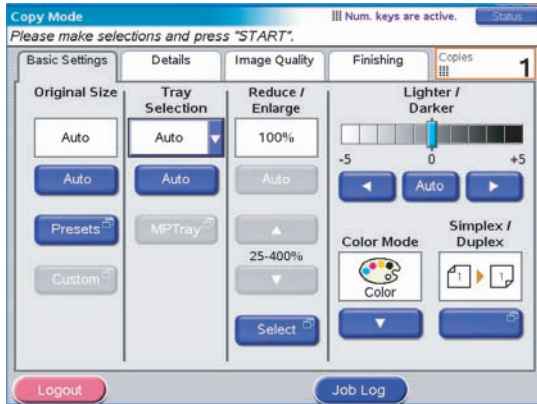

## Logging out

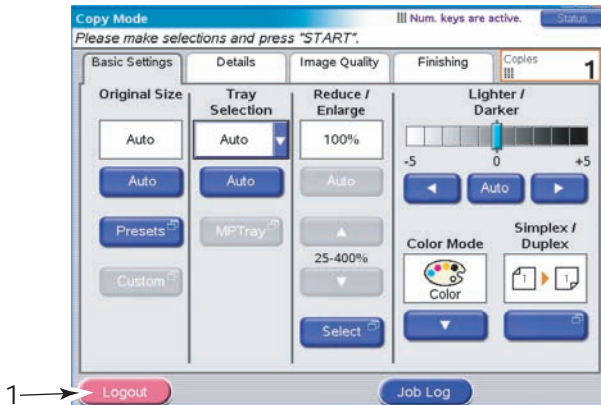

1. When you have finished using the scanner unit, press the Logout button (1) to return to the access control screen.

## Status monitoring

See also “Appendix C – Scanner Unit Status” on page 187.

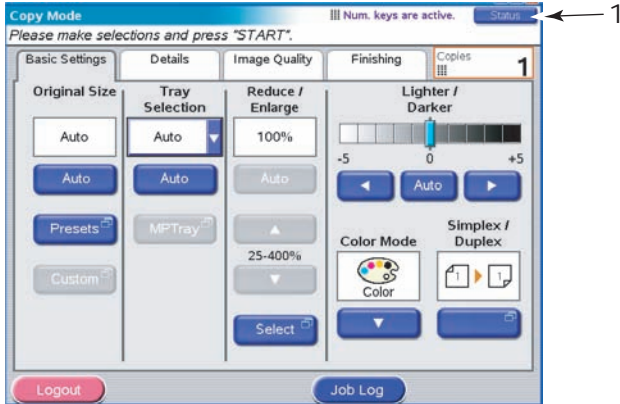

The Status button (1) changes color depending on the status of the MFP:

- > Blue: ready status
- > Orange: warning status
- > Red: Alarm status

1. For detailed status information, press the Status button to display the status window.

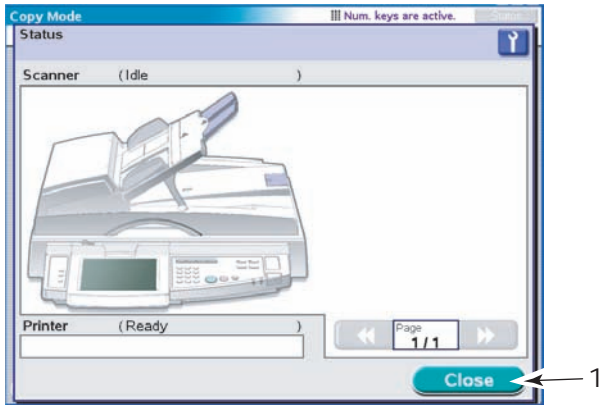

2. Press the Close button to close the status window.

## Using the Help facility

To obtain help, press the **HELP** button on the scanner unit control panel.

1. Select a topic and then press the Go To button (1).

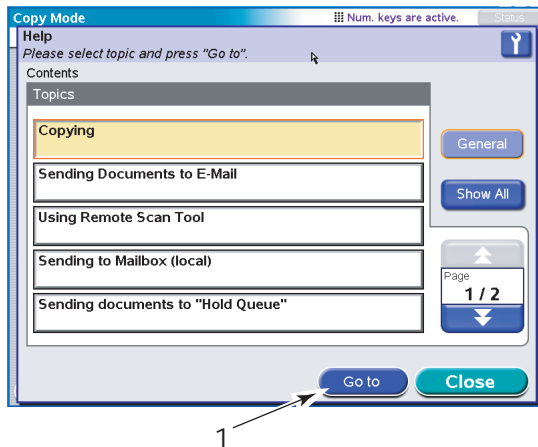

2. Navigate and read the help information you need.

3. At any time you can press the Maintenance button (1) to show the Dealer's Information screen for dealer contact information, then press the Close button to return to the Help screen.

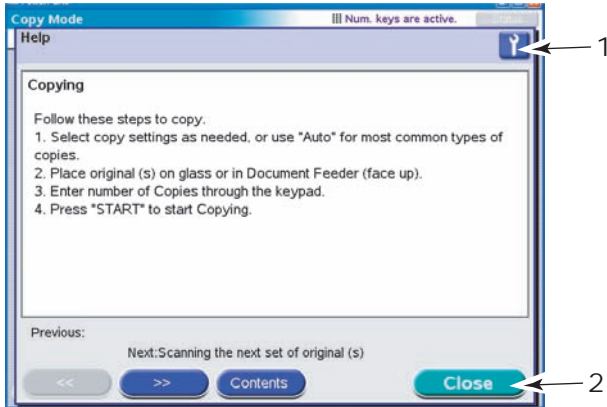

4. Press the Close button (2) to leave the Help screen.

## Avoiding incompatibility situations

It is possible to request your MFP to carry out instructions that would involve media incompatibilities e.g. if you are copying an A4 original with the Reduce/Enlarge setting at 141% (A4 to A3) and the (printer unit) Tray Selection set at Tray 1 containing A4 media. The MFP will detect such situations and issue a message to indicate that your request has been cancelled referring you to this guide.

To avoid an incompatibility such as the above, make sure that your chosen image size fits on the media size in the selected printer unit tray.

Other incompatibilities can arise in connection with punching and stapling requests and information to help you avoid such requests is presented in ["Appendix D – Media support information" on page 188.](#)

Information about document sizes that can be scanned either on the document glass or in the ADF when using the default Auto setting is provided in ["Appendix E – Auto detection paper sizes" on page 196.](#)

# Copying

Documents to be copied are scanned in the scanner unit (document glass or ADF) and copies are automatically printed in the printer unit.

Carry out the following steps:

1. Copy Mode is the default function of the MFP. If required, press the **COPY** button on the scanner unit control panel to show the Copy Mode screen.



2. Place the document to be copied on the scanner unit glass or ADF.
3. Make your selections from the Copy Mode touch screen tabs (detailed below).
4. Press the **START** button to produce your copies.

# Basic Settings tab

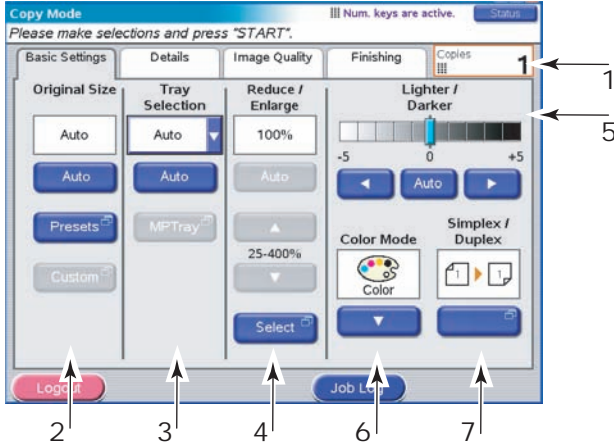

No	Feature	Options	Description
1	Copies	1-999	Allows you to specify the number of copies to be made. The maximum number of copies that can be set per job is 999.
2	Original Size	Auto, 5.5x8.5, 5.5x8.5R, 8.5x11, 8.5x11R, 8.5x13, 8.5x14, 11x17, A5, A5R, A4, A4R, A3, B5, B5R, B4, Custom	Allows you to select the paper size to match the document size.
3	Tray Selection	Auto, Tray 1, Tray 2, Tray 3, Tray 4, MPTray	Allows you to define the paper tray for printing. Auto - Allows for automatic tray selection based on the document image size and/or scaling setting defined.
4	Reduce/Enlarge	Auto, Preset, 25% - 400% by 1%, Select	Allows you to scale the copy.

No	Feature	Options	Description
5	Lighter/Darker	Auto, -5 to +5 by 1	Allows you to adjust the brightness levels for scanning and printing. This is not applied (disabled) if Auto Exposure is set to ON.
6	Color Mode	Color, B&W	Allows you to select the color mode of the output. If Color is selected, scanned image is printed in full color (Image Type=24bit color). If B&W is selected, scanned image is printed in 8-bit grayscale. No color settings are applied.
7	Simplex/ Duplex	1to1 Sided, 1to2 Sided, 2to1 Sided, 2to2 Sided,	Allows you to specify the original document image layout and the desired printed document image layout. If you specify 2to1Sided or 2to2 Sided, set your original documents on the ADF.
	Simplex/ Duplex (Duplex Layout)	Top/Top, Top/Bottom	Allows you to define the orientation of the front and back sides of a duplex page (for scanning and printing).

**NOTE**

*If you specify Auto for Tray Selection, the MFP automatically selects the tray (from Trays 1 to 4) that can supply the most appropriate paper. To print on paper from the MPTray, specify MPTray for Tray Selection. If your copy is produced on paper you did not expect to be used, specify the appropriate tray manually and retry. In Copy Mode, there are limitations on the combination of Media Type, Media Weight and Paper Size. For information on paper size combinations, refer to "[Appendix D – Media support information](#)" on page 188.*

## Details tab

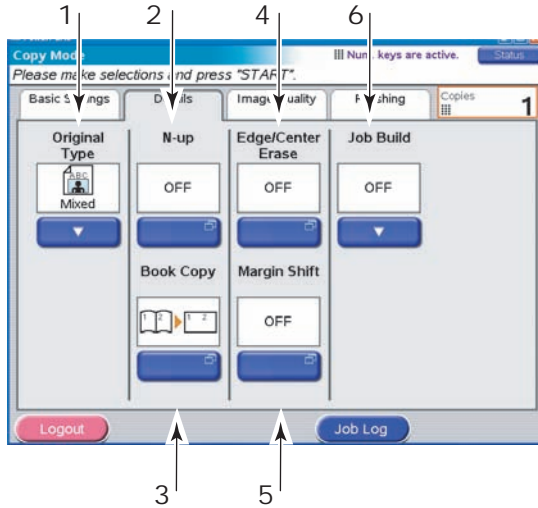

No	Feature	Options	Description
1	Original Type	Mixed, Text, Photo	Allows you to specify the type of images on the document. This allows automatic (pre-set) optimization of image quality settings.
2	N-up	OFF, 2-Up, 4-Up, 8-Up	Allows you to print multiple pages of the document to a single sheet of paper. Layout orientation and image order is fixed. If you specify 8-Up, you can only make a copy on a document the same size as the original document. If you specify 2-Up, 4-Up or 8-Up, set your original documents on the ADF.



No	Feature	Options	Description
3	Book Copy	1 to 1 Side, Book to 1 side, Book to 2 sides	Allows you to select how book copies are printed. If you specify Book to 1 side or Book to 2 sides, set your original document on the glass.
	Book Copy (Duplex Layout)	Top/Top, Top/Bottom	Allows you to select how book copies are printed on both sides of the output page.
4	Edge/Center Erase	Edge OFF / Top / Bottom / Left / Right Metric: 0-50mm in 1mm increments Inch: 0" – 2.0" in 0.1" increments	Allows you to block out the peripheral areas of the document where spurious shadows and borders may arise when copying with the document cover open (such as with books and magazines) or for other purposes.
		Center Metric: 0-50mm in 1mm increments Inch: 0" – 2.0" in 0.1" increments	Allows you to block out a centered rectangular area of the document where spurious shadows and borders may arise when copying bound originals (books, magazines) with the center spread layout.
5	Margin Shift	OFF / Top / Bottom / Left / Right	Allows you to shift the document image up / down / left / right and sets the margin areas. Only one of Top / Bottom / Left / Right can be set. For 2-sided output, the front side and back side margin shifts may be separately set. Please take care to set margin shifts correctly.
6	Job Build	OFF / ON	Allows you to construct a single copy job or scan job from multiple individual sheets or originals.

## Image Quality tab

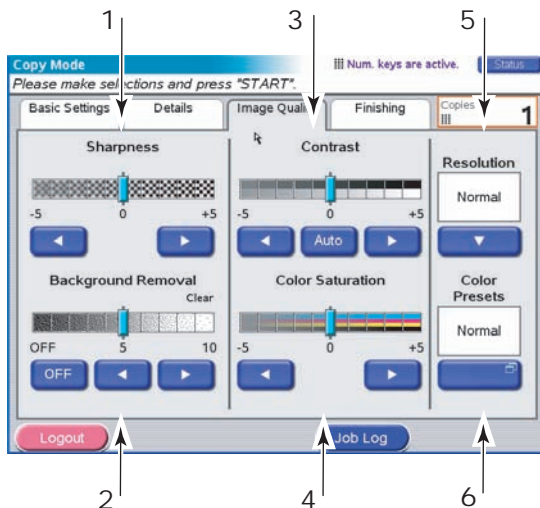

No	Feature	Options	Description
1	Sharpness	-5 to +5 by 1	Allows you to enhance the image's outline, letters, lines when printing.
2	Background Removal	OFF, 1 to 10 by 1	Allows you to block out the color background of the image (assuming document has a color background) - such that the background color is not printed.
3	Contrast	Auto, -5 to +5 by 1	Allows you to adjust the contrast levels for scanning and printing. This is not applied (disabled) if Auto is set to ON.

No	Feature	Options	Description
4	Color Saturation	-5 to +5 by 1	Allows you to adjust the overall color saturation (neutrally across all colors) of the image. Color Saturation is not available where Color Mode is set to B&W or Color Presets is set to Vivid.
5	Resolution	Normal, High Quality	Allows you to select an appropriate balance between speed (normal) and quality (high quality).
6	Color Presets	Normal, Vivid, Warm, Cool	Allows you to select pre-defined color mode settings (affects the overall color tone). Vivid - increased overall color saturation. Warm - increased overall reddish hue saturation. Cool - increased overall bluish hue saturation.

# Finishing tab

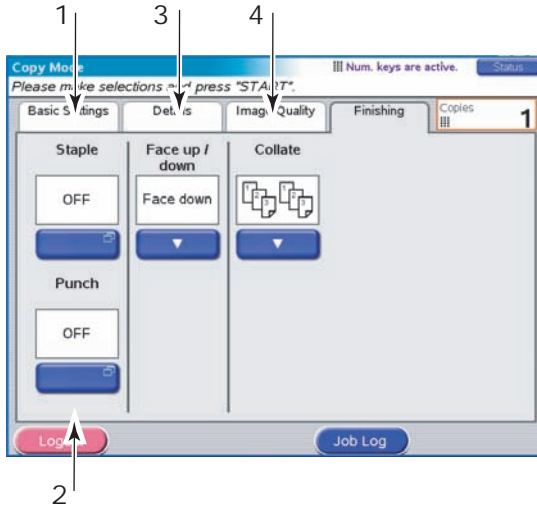

No	Feature	Options	Description
1	Staple	OFF / Left Position / Right Position	Allows you to select the staple options (and sub-options) that will be applied to the document.
2	Punch	OFF / Left Position / Right Position	Allows you to select the punching options (and sub-options) that will be applied to the document.
3	Face up/down	Face up, Face down	Allows you to select the output placement and stacking order.
4	Collate	Collate, Group	Collate prints 1 entire copy/set of the multiple copy document at a time (e.g. pages 1,2,3,1,2,3,1,2,3,...) Group batch prints the multiple copy document page by page (e.g. pages 1,1,1,2,2,2,3,3,3,...)

# Scanning

Your MFP can carry out the following scanning functions:

- > E-mail send mode (**SCAN TO E-MAIL** button)

Scan to e-mail: An original document is scanned and the data is sent by e-mail as an attachment.

- > Network send mode (**SCAN TO NETWORK** button)

Scan to FTP: An original document is scanned and the data is sent to an FTP server.

PC remote scan: Under remote control, an original document is scanned and the data is sent to a host PC.

- > Mailbox send mode (**SCAN TO MAILBOX** button)

Scan to Mailbox: An original document is scanned and the data is saved in a mailbox.

Scan to Hold Queue: An original document is scanned and the data is saved in the hold queue.

## NOTE

*Additional features involving, for example the Fiery Remote Scan tool or Web Scan Tool for accessing files in the mailbox are described in the Fiery documentation.*

*The TIFF file format supported is compliant with the TIFF v6 specification with additional qualifiers for supporting JPEG compressed images within the TIFF file. Single and multiple page files are supported. The following TIFF viewers are recommended: ACD Systems ACDSsee, Adobe Photoshop.*

## E-mail send mode

The main steps in summary are:

- Press the **SCAN TO E-MAIL** button.
- On the Address tab, enter address and subject details.
- On the Message Text tab, enter your e-mail message.
- On the Attachments tab, define your attachment properties, using the Advanced Settings features as required.

- (e) Set your document on the scanner unit and press **START**.

These steps are expanded below.

1. Press the **SCAN TO E-MAIL** button to display the E-mail Send Mode screen at the Address tab



2. Press the To button (1) and enter an e-mail address via one of the following buttons:
- > Address Book (2)
  - > LDAP (3)
  - > Soft Keyboard (4)
  - > Fax Gateway (5)

## Address Book

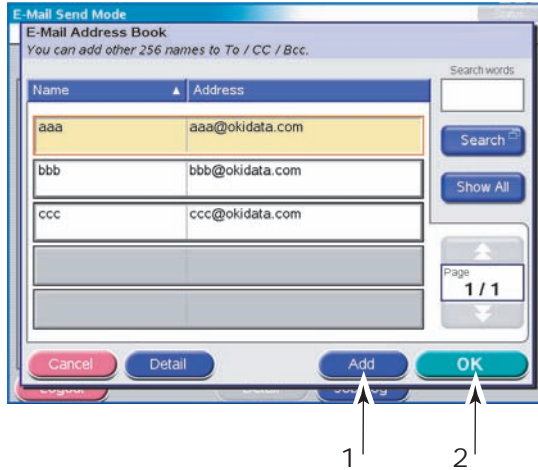

- (a) Touch on an e-mail address to select it.
- (b) Press the Add button (1) to add this address to the list.
- (c) Repeat (a) and (b) as required to create the address list.
- (d) Press the OK button (2) to place the list of addresses in the To destination field.

## LDAP

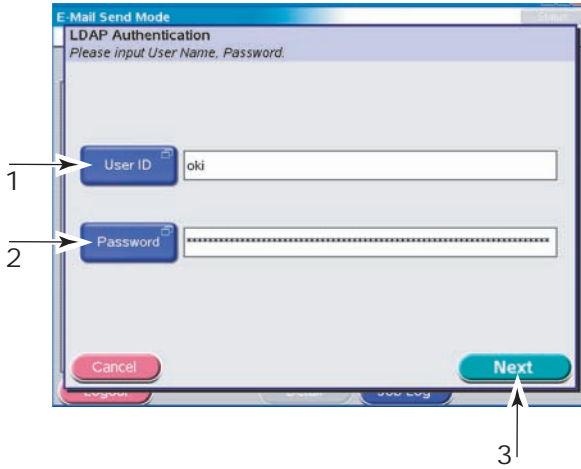

- (a) Press the User ID button (1) and enter your user ID via the soft keyboard then press the OK button.
- (b) Press the Password button (2) and enter your password via the soft keyboard then press the OK button.



- (c) Press the Next button (3).

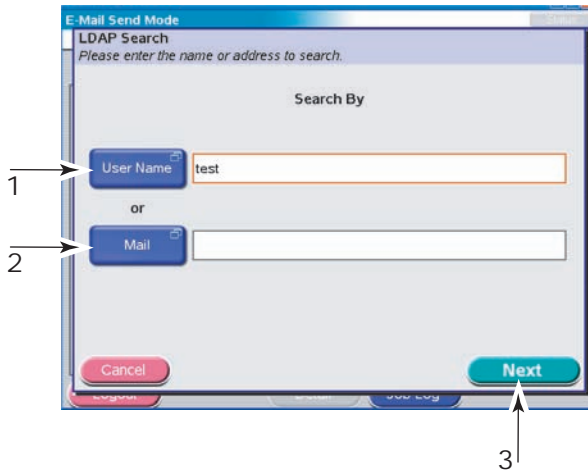

- (d) Press either the User Name (1) or Mail button (2) to enter your search value via the soft keyboard, then press the OK button.
- (e) Press the Next button (3).

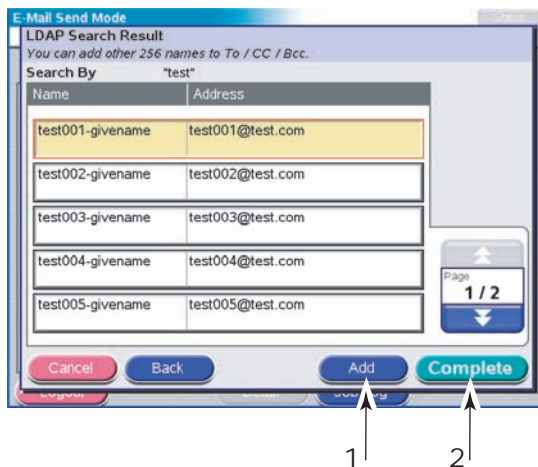

- (f) Select an address from the list displayed and press the Add button (1) to add this address to your destination list.
- (g) Repeat (f) as required to create a destination list.
- (h) Press the Complete button (2) to place the list of addresses in the To destination field.

### Soft Keyboard

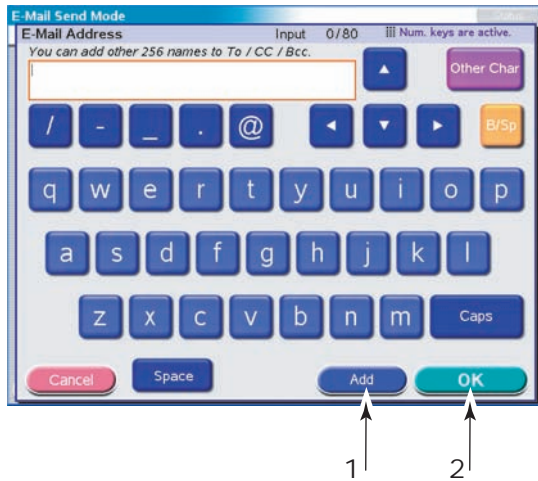

- (a) Enter an address via the soft keyboard.
- (b) Press the Add button (1) to add this address to the list.
- (c) Repeat (a) and (b) as required to create the address list.
- (d) Press the OK button (2) to place the list of addresses in the To destination field.

## Fax Gateway

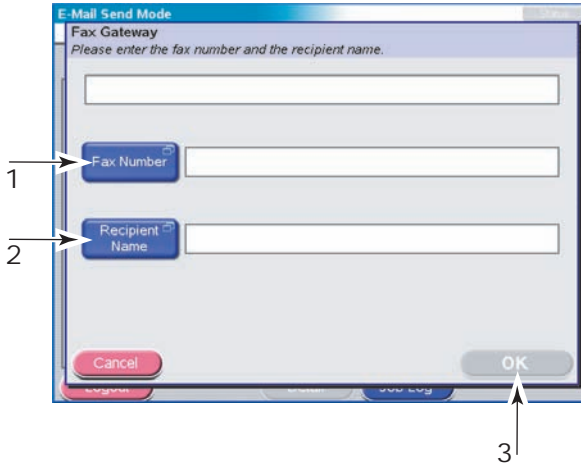

- (a) Press the Fax Number button (1), enter a fax number via the soft keyboard, then press the OK button.
  - (b) Press the Recipient Name button (2), enter a recipient name via the soft keyboard, then press the OK button.
  - (c) Press the OK button (3).
- 3.** Repeat Step 2 as required with the cc and Bcc buttons on the Address tab.
  - 4.** Press the Subject button on the Address tab and use the soft keyboard to enter the subject of your e-mail, then press the OK button.

5. Touch the Message Text tab, press the Edit Message button (1), enter your e-mail message via the soft keyboard and press the OK button.

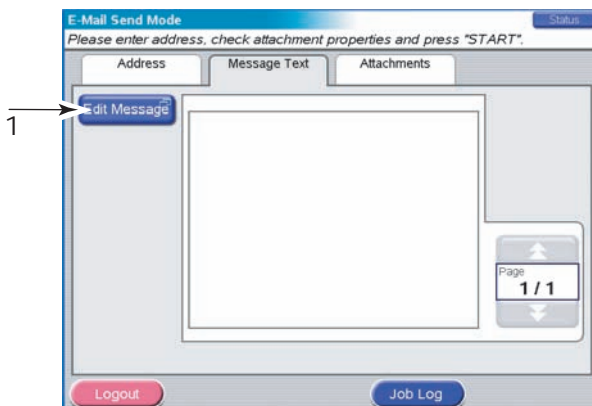

6. Touch the Attachments tab.

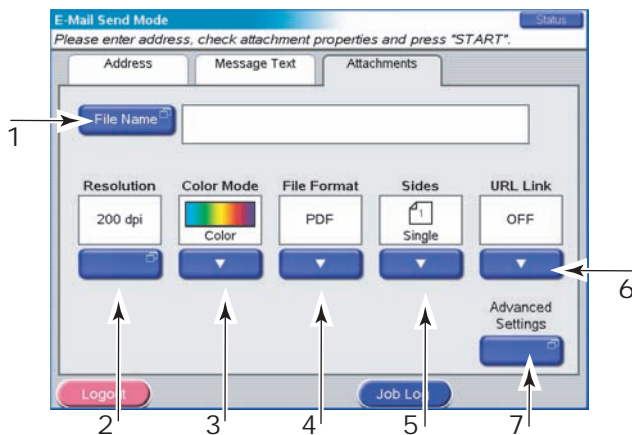

(a) Press the File Name button (1) and enter a name for your scanned file via the soft keyboard then press the OK button.

(b) Use the following features as required:

**Resolution (2)** (150, 200, 300, 400, 600dpi)

**Color Mode (3)** (Color, Grayscale, B/W)

**File Format (4)** (JPEG, PDF, TIFF)

**Sides (5)** (Single, Top/Top, Top/Bottom)

Allows you to define simplex or duplex and the duplex orientation of front and back sides of a page for scanning.

**URL Link (6)** (On, Off)

Select Off to send the scanned image as an attachment. Select On to send the scanned image as a URL.

(c) To access advanced settings, press the Advanced Settings button (7):

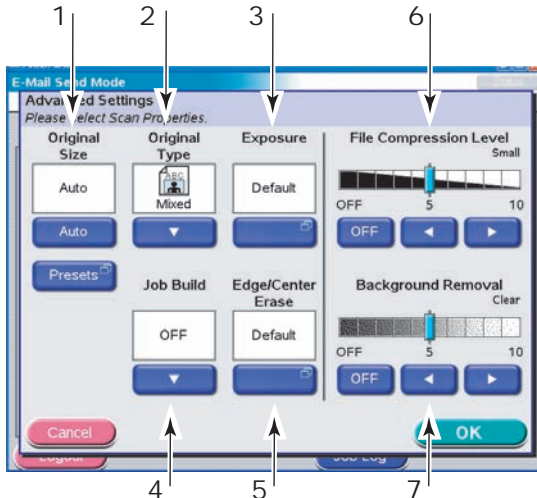

Select from the following features as required:

NO	Feature	Options	Description
1	Original Size	Auto, 5.5x8.5, 5.5x8.5R, 8.5x11, 8.5x11R, 8.5x13, 8.5x14, 11x17, A5, A5R, A4, A4R, A3, B5, B5R, B4	Allows you to select the scanned document size.
2	Original Type	Mixed, Text, Photo	Allows you to specify the type of images on the document. This allows automatic (pre-set) optimization of image quality settings.
3	Exposure	-5 to +5 by 1	Allows you to select Brightness level and Contrast level.
4	Job Build	OFF / ON	Allows you to construct a single copy job or scan job from multiple individual sheets or originals.
5	Edge/Center Erase	OFF / Edge Metric: 0-50mm in 1mm increments Inch: 0" – 2.0" in 0.1" increments	Allows you to block out the peripheral areas of the document where spurious shadows and borders may arise when scanning with the document cover open (such as with books and magazines) or for other purposes.
		Center Metric: 0-50mm in 1mm increments Inch: 0" – 2.0" in 0.1" increments	Allows you to block out a centered rectangular area of the document where spurious shadows and borders may arise when scanning bound originals (books, magazines) with the center spread layout.
6	File Compression Level	Off, 1 to 10 by 1	Allows you to select compression level.

NO	Feature	Options	Description
7	Background Removal	OFF, 1 to 10 by 1	Allows you to block out the color background of the image (assuming document has a color background) - such that the background color is not displayed.

7. Place the document to be scanned on the scanner unit glass or ADF.
8. Press the **START** button.

## Confirming e-mail transmission

You can check the transmission status of e-mails from:

- > Job Log screen: Press the Job Log button to display this screen.
- > E-mail Log Report: To print this report, press the **SETUP** button on the scanner unit control panel then press the Report button followed by the Print button associated with E-mail Log.

## Network send mode – scan to FTP

The main steps in summary are:

- (a) Press the **SCAN TO NETWORK** button.
- (b) Press the FTP Server button (set by default).
- (c) On the FTP Server tab, enter the FTP Server name.
- (d) On the Attachments tab, define your attachment properties, using the Advanced Settings features as required.
- (e) Set your document on the scanner unit and press **START**.

These steps are expanded below.

1. Press the **SCAN TO NETWORK** button to display the Network Send Mode screen.

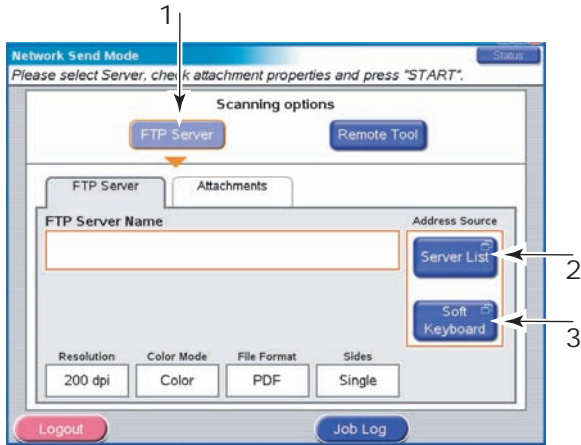

2. Press the FTP Server button (1) (set by default) and enter an FTP server name via one of the following buttons:
  - > Server List (2)
  - > Soft keyboard (3)



## Server List

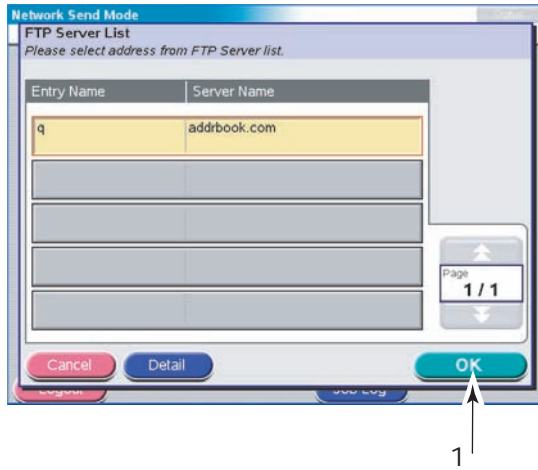

- (a) Touch on an FTP server name to select it.
- (b) Press the OK button (1) to place the name in the FTP Server Name box on the FTP Server tab.

## Soft Keyboard

Use the soft keyboard and respective buttons to enter the following host information:

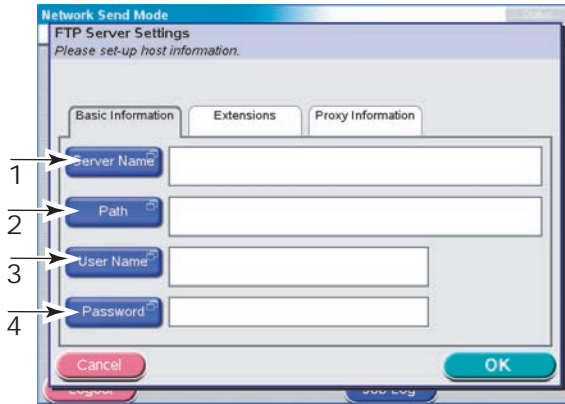

- (a) Basic Information tab: Server name (1), Path (2), User Name (3), Password (4)

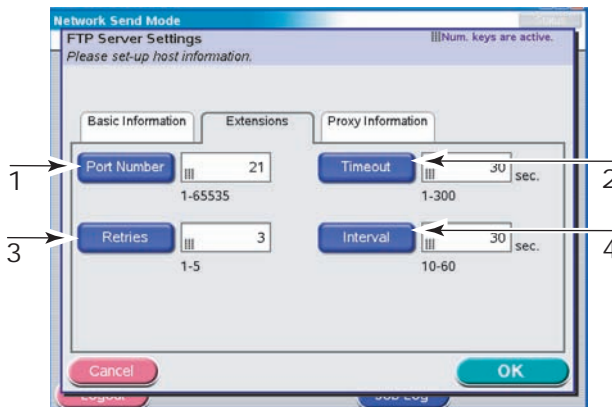

- (b) Extensions tab: Port Number (1), Timeout (2), Retries (3), Interval (4)

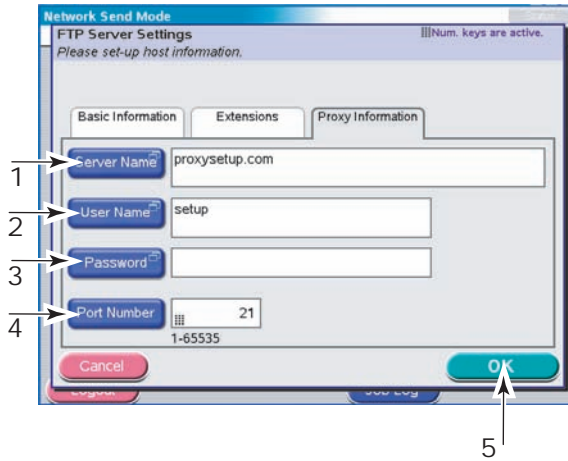

- (c) Proxy Information tab: Server Name (1), User Name (2), Password (3), Port Number (4)
- (d) Press the OK button (5) to enter the data and place the name in the FTP Server Name box on the FTP Server tab.

3. Touch the Attachments tab.

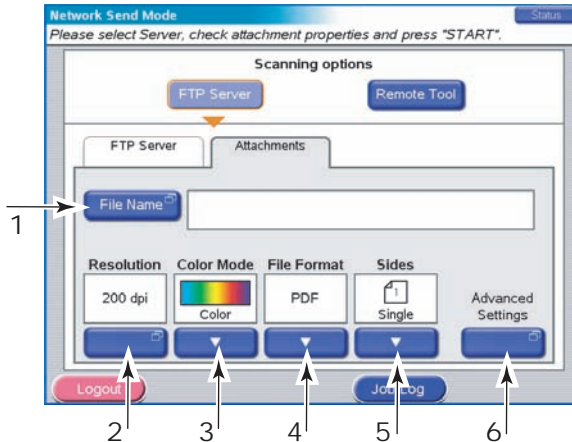

(a) Press the File Name button (1) and enter a name for your scanned file via the soft keyboard then press the OK button.

(b) Use the following features as required:

**Resolution (2)**(150, 200, 300, 400, 600dpi)

**Color Mode (3)**(Color, Grayscale, B/W)

**File Format (4)**(JPEG, PDF, TIFF)

**Sides (5)** (Single, Top/Top, Top/Bottom)

Allows you to define simplex or duplex and the duplex orientation of front and back sides of a page for scanning.

- (c) To access advanced settings, press the Advanced Settings button (6):

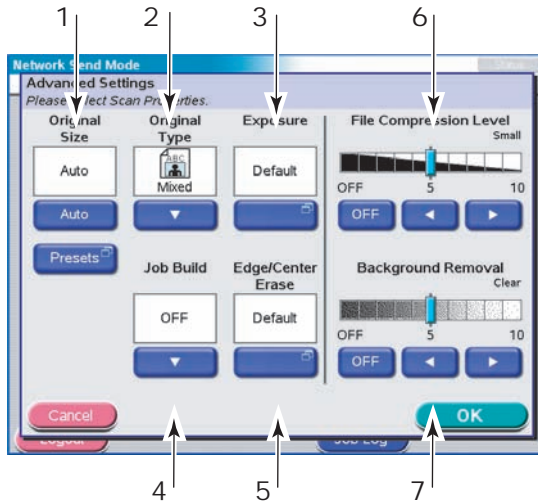

Select from the following features as required:

No	Feature	Options	Description
1	Original Size	Auto, 5.5x8.5, 5.5x8.5R, 8.5x11, 8.5x11R, 8.5x13, 8.5x14, 11x17, A5, A5R, A4, A4R, A3, B5, B5R, B4	Allows you to select the scanned document size.
2	Original Type	Mixed, Text, Photo	Allows you to specify the type of images on the document. This allows automatic (pre-set) optimization of image quality settings.
3	Exposure	-5 to +5 by 1	Allows you to select Brightness level and Contrast level.
4	Job Build	OFF / ON	Allows you to construct a single copy job or scan job from multiple individual sheets or originals.

No	Feature	Options	Description
5	Edge/Center Erase	OFF / Edge Metric: 0-50mm in 1mm increments Inch: 0" – 2.0" in 0.1" increments	Allows you to block out the peripheral areas of the document where spurious shadows and borders may arise when scanning with the document cover open (such as with books and magazines) or for other purposes.
		Center Metric: 0-50mm in 1mm increments Inch: 0" – 2.0" in 0.1" increments	Allows you to block out a centered rectangular area of the document where spurious shadows and borders may arise when scanning bound originals (books, magazines) with the center spread layout.
6	File Compression Level	Off, 1 to 10 by 1	Allows you to select compression level.
7	Background Removal	OFF, 1 to 10 by 1	Allows you to block out the color background of the image (assuming document has a color background) - such that the background color is not displayed.

4. Place the document to be scanned on the scanner unit glass or ADF.
5. Press the **START** button.

## Confirming FTP transmission

You can check FTP transmission status from:

- > Job Log screen: Press the Job Log button to display this screen.
- > FTP Report: To print this report, press the **SETUP** button on the scanner unit control panel then press the Report button followed by the Print button associated with FTP Report.

## Remote scan mode

The main steps in summary are:

- (a) Press the **SCAN TO NETWORK** button.
- (b) Press the Remote Tool button.
- (c) Set your document on the scanner unit.
- (d) Press the On Line button.
- (e) After the document has been scanned under control of the remote PC, the status returns to Off Line automatically.

These steps are expanded below.

1. Press the **SCAN TO NETWORK** button to display the Network Send Mode screen.

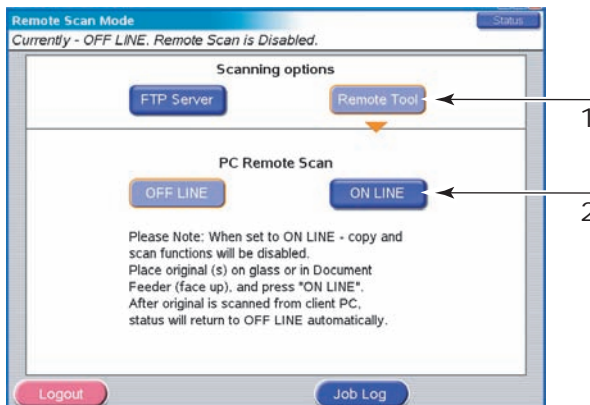

2. Press the Remote Tool button (1) to enter PC Remote Scan mode in the Off Line status.
3. Set your document on the scanner unit.
4. Press the On Line button (2) and when the document has been scanned from the client PC the status will return to Off Line automatically after a time-out. During On Line

status, copying and scanning functions from the Scanner Unit control panel are disabled.

## Mailbox send mode

In the context of this section, dealing with scan to mailbox and scan to hold queue functions, the following table summarizes mailbox and hold queue properties.

property	mailbox	Hold Queue
Description	Simple file server in the printer unit hard disk drive.	A print queue in the printer unit hard disk drive.
Quantity	As required.	1
Name allocated	Yes	No
Password control	Yes	No
Direct operations	Create a new mailbox. Delete a mailbox. Edit a password. Save a file in a mailbox. Delete a file in a mailbox.	Save a file in the hold queue.
Remote operations (by a PC on the network)	Import a file to the PC. Delete a file.	Preview a file. Import a file to PC. Edit a file. Print a file. Delete a file. Rename a file.
Remote operation tools	Fiery Remote Scan MS Internet Explorer.	Fiery Command Work Station.

Mailbox send mode – scan to mailbox

The main steps in summary are:

- (a) Press the **SCAN TO MAILBOX** button.
- (b) Press the Mailbox button (set by default).
- (c) On the Mailbox tab, enter the mailbox name.
- (d) On the Attachments tab, define your attachment properties, using the Advanced setting features as required.
- (e) Set your document on the scanner unit.



- (f) Press the **START** button on the Scanner Unit control panel.

These steps are expanded below.

1. Press the **SCAN TO MAILBOX** button to display the Mailbox Send Mode screen.

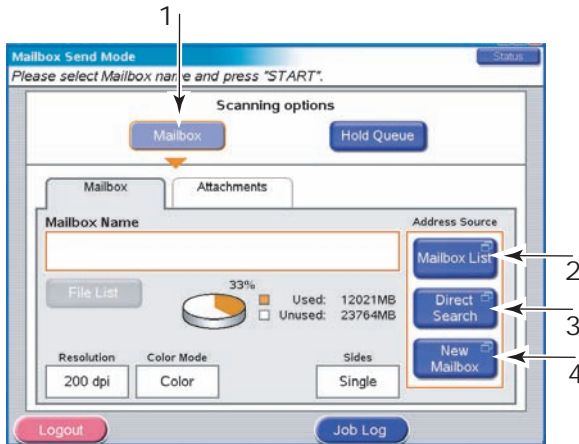

2. Press the Mailbox button (1) (set by default).
3. On the Mailbox tab, enter the Mailbox name via one of the following buttons:
  - > Mailbox List (2)
  - > Direct Search (3)
  - > New Mailbox (4)

## Mailbox List

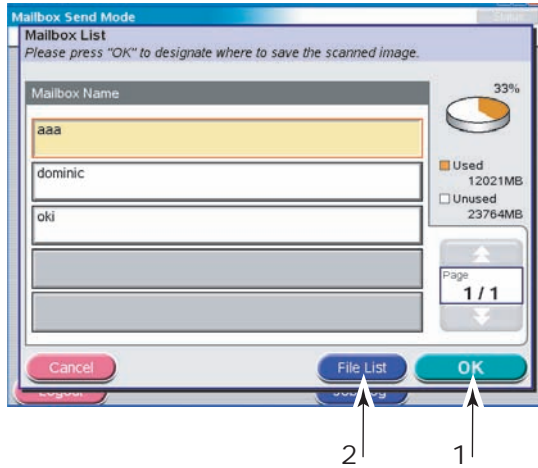

- (a) Press the Mailbox List button.
- (b) Touch a mailbox name to select it.
- (c) Press the OK button (1) to begin to enter the name in the Mailbox Name box on the mailbox tab.
- (d) To see a list of the files in the selected mailbox, press the File List button (2).
- (e) Enter the password for the selected mailbox on the password authentication pop-up screen and press the OK button.

## Direct Search



- (a) Press the Direct Search button.
- (b) Use the soft keyboard to enter a mailbox name then press the OK button (1).
- (c) Use the soft keyboard to enter the associated mailbox password button then press the OK button.

## New Mailbox

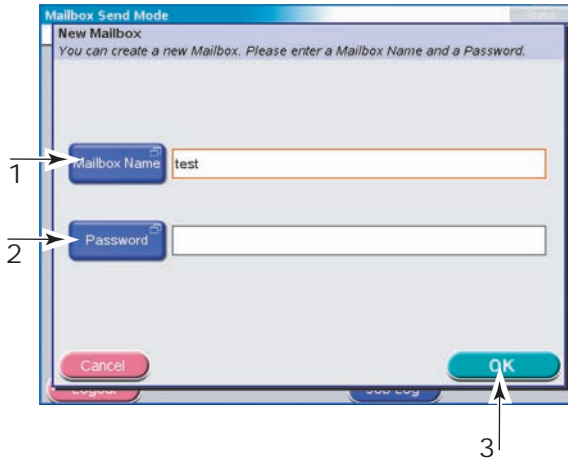

- (a) Press the New Mailbox button.
  - (b) Press the Mailbox Name button (1), enter a name for the new mailbox via the soft keyboard then press the OK button.
  - (c) Press the Password button (2), enter a password for the new mailbox via the soft keyboard then press the OK button.
  - (d) Press the OK button (3).
- 4.** If you wish to check the list of files already stored in your selected mailbox, press the File List button, view the list then press the OK button.

5. Touch the Attachments tab.

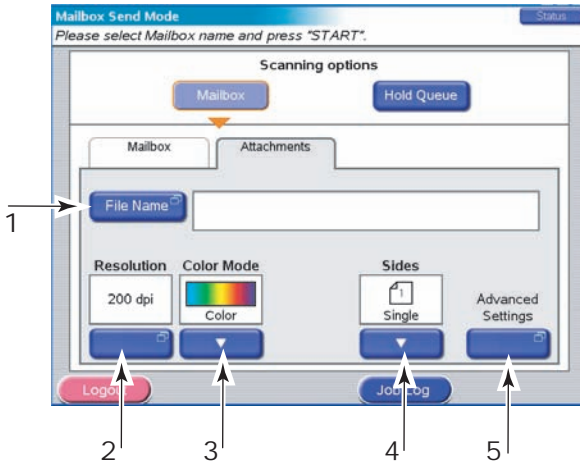

(a) Press the File Name button (1) and enter a name for your scanned file via the soft keyboard then press the OK button.

(b) Use the following features as required:

**Resolution (2)** (150, 200, 300, 400, 600dpi)

**Color Mode (3)** (Color, Grayscale, B/W)

**Sides (4)** (Single, Top/Top, Top/Bottom)

Allows you to define simplex or duplex and the duplex orientation of front and back sides of a page for scanning.

- (c) To access advanced settings, press the Advanced Settings button (5):

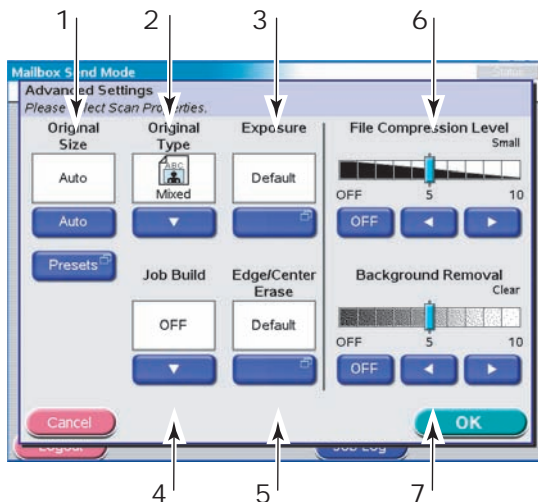

Select from the following features as required:

No	Feature	Options	Description
1	Original Size	Auto, 5.5x8.5, 5.5x8.5R, 8.5x11, 8.5x11R, 8.5x13, 8.5x14, 11x17, A5, A5R, A4, A4R, A3, B5, B5R, B4	Allows you to select the scanned document size.
2	Original Type	Mixed, Text, Photo	Allows you to specify the type of images on the document. This allows automatic (pre-set) optimization of image quality settings.
3	Exposure	-5 to +5 by 1	Allows you to select Brightness level and Contrast level.
4	Job Build	OFF / ON	Allows you to construct a single copy job or scan job from multiple individual sheets or originals.

No	Feature	Options	Description
5	Edge/Center Erase	OFF / Edge Metric: 0-50mm in 1mm increments Inch: 0" – 2.0" in 0.1" increments	Allows you to block out the peripheral areas of the document where spurious shadows and borders may arise when scanning with the document cover open (such as with books and magazines) or for other purposes.
		Center Metric: 0-50mm in 1mm increments Inch: 0" – 2.0" in 0.1" increments	Allows you to block out a centered rectangular area of the document where spurious shadows and borders may arise when scanning bound originals (books, magazines) with the center spread layout.
6	File Compression Level	Off, 1 to 10 by 1	Allows you to select compression level.
7	Background Removal	OFF, 1 to 10 by 1	Allows you to block out the color background of the image (assuming document has a color background) - such that the background color is not displayed.

6. Place the document to be scanned on the scanner unit glass or ADF.
7. Press the **START** button.

## Mailbox send mode – scan to Hold Queue

The main steps in summary are:

- (a) Press the **SCAN TO MAILBOX** button.
- (b) Press the Hold Queue button.
- (c) On the Attachments tab, define your attachment properties, using the Advanced setting features as required.
- (d) Set your document on the scanner unit.
- (e) Press the **START** button on the Scanner Unit control panel.

These steps are expanded below.

1. Press the **SCAN TO MAILBOX** button to display the Mailbox Send Mode screen.

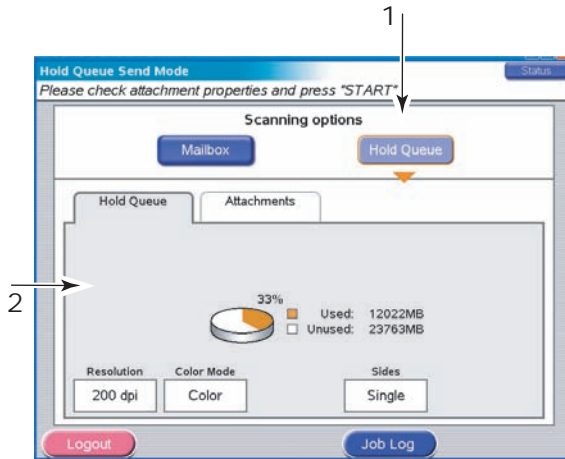

2. Press the Hold Queue button (1).
3. On the Hold Queue tab (2), check the displayed settings for your scanned file.



4. Touch the Attachments tab.

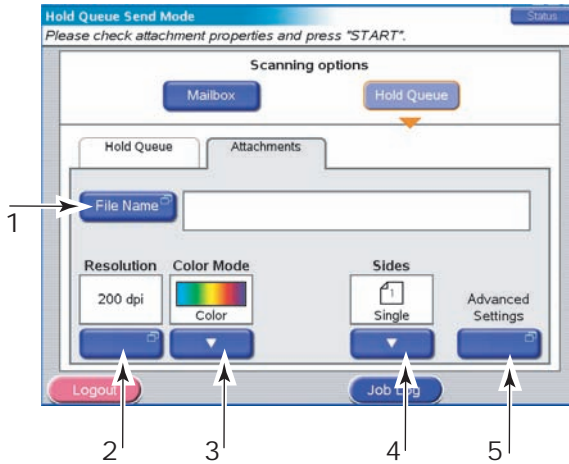

(a) Press the File Name button (1) and enter a name for your scanned file via the soft keyboard then press the OK button.

(b) Use the following features as required:

**Resolution (2)** (150, 200, 300, 400, 600dpi)

**Color Mode (3)** (Color, Grayscale, B/W)

**Sides (4)** (Single, Top/Top, Top/Bottom)

Allows you to define simplex or duplex and the duplex orientation of front and back sides of a page for scanning.

- (c) To access advanced settings, press the Advanced Settings button (5):

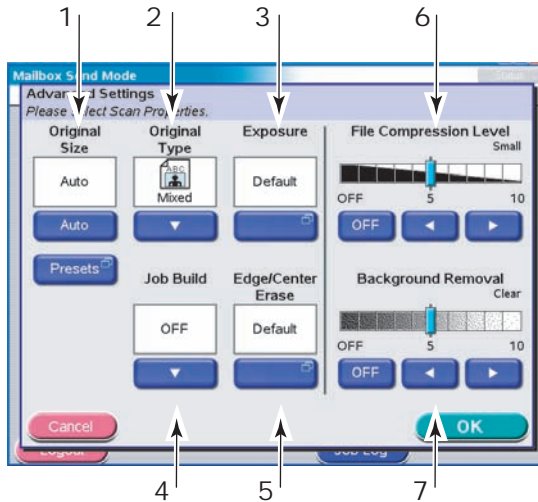

Select from the following features as required:

No	Feature	Options	Description
1	Original Size	Auto, 5.5x8.5, 5.5x8.5R, 8.5x11, 8.5x11R, 8.5x13, 8.5x14, 11x17, A5, A5R, A4, A4R, A3, B5, B5R, B4	Allows you to select the scanned document size.
2	Original Type	Mixed, Text, Photo	Allows you to specify the type of images on the document. This allows automatic (pre-set) optimization of image quality settings.
3	Exposure	-5 to +5 by 1	Allows you to select Brightness level and Contrast level.
4	Job Build	OFF / ON	Allows you to construct a single copy job or scan job from multiple individual sheets or originals.

No	Feature	Options	Description
5	Edge/Center Erase	OFF / Edge Metric: 0-50mm in 1mm increments Inch: 0" – 2.0" in 0.1" increments	Allows you to block out the peripheral areas of the document where spurious shadows and borders may arise when scanning with the document cover open (such as with books and magazines) or for other purposes.
		Center Metric: 0-50mm in 1mm increments Inch: 0" – 2.0" in 0.1" increments	Allows you to block out a centered rectangular area of the document where spurious shadows and borders may arise when scanning bound originals (books, magazines) with the center spread layout.
6	File Compression Level	OFF, 1 to 10 by 1	Allows you to select compression level.
7	Background Removal	OFF, 1 to 10 by 1	Allows you to block out the color background of the image (assuming document has a color background) - such that the background color is not displayed.

5. Place the document to be scanned on the scanner unit glass or ADF.
6. Press the **START** button.

# Consumables and maintenance – printer unit

This section explains how to replace consumable and maintenance items when due. As a guide, the life expectancy of these items is:

- > Toner — estimated 15,000 Letter pages at 5% coverage.  
The printer unit is shipped with sufficient toner for 7,500 Letter pages in the print cartridges.
- > Image drum — estimated 30,000 Letter pages at 3 pages per job — will vary depending on the number of printed pages per job.
- > Transfer belt — Approximately 100,000 Letter pages
- > Fuser — Approximately 100,000 Letter pages

## Checking consumable/maintenance item usage

At any time, you can check how much of each consumable/maintenance item is left by using the appropriate menus. For example, enter the menu system and follow the path:

Configuration>Supplies Life>Cyan Toner

The percentage of Cyan Toner remaining is displayed on the display panel and the printer unit then returns to the ready to print status.

## Replacement indications

The display panel provides messages to the effect that consumables/maintenance items are running low or nearing end of life followed some time later by a message that replacement is required. You should replace the item as soon as possible after this message is displayed to avoid the possibility of print quality being compromised.

The paper feed rollers and the multi-purpose (MP) tray feed rollers do not have any replacement warning messages. Recommended replacement: after approximately 120,000 Letter sheets.

## Consumable item order information

Item	Life	Order number
Toner, Black	15,000 Letter pages <sup>a</sup>	42918924
Toner, Cyan	15,000 Letter pages <sup>a</sup>	42918923
Toner, Magenta	15,000 Letter pages <sup>a</sup>	42918922
Toner, Yellow	15,000 Letter pages <sup>a</sup>	42918921
Image drum, Black	30,000 Letter pages <sup>b</sup>	42918120
Image drum, Cyan	30,000 Letter pages <sup>b</sup>	42918119
Image drum, Magenta	30,000 Letter pages <sup>b</sup>	42918118
Image drum, Yellow	30,000 Letter pages <sup>b</sup>	42918117
Staples	3 x 3000 staples	42937601

a. Estimated life at 5% coverage (printers ship with 7,500 - page standard toner cartridges).

b. Estimated life, 3 pages per job (will vary depending on number of printed pages per job).

## Maintenance item order details

Item	Life	Order number
Fuser unit	100,000 Letter pages	120V:57102201 230V: 57102202
Belt unit	100,000 Letter pages	57102301
Waste toner bottle	30,000 Letter pages avg	57102401

## Replacing consumables/maintenance items

Each consumable or maintenance item comes complete with its own installation details which give full instructions on replacement. You are advised to follow these instructions carefully.

### **IMPORTANT!**

**Only use genuine Oki Original consumables to ensure the best quality and performance from your hardware. Non-Oki Original products may damage your printer unit's performance and invalidate your warranty.**

## Cleaning the LED heads

You are advised to clean the LED heads:

- > any time you replace a toner cartridge (a LED lens cleaner is enclosed with each replacement toner cartridge)
- > if printing is showing signs of faded images, white stripes or blurred letters

You can use a LED lens cleaner or dry, soft cloth for cleaning the LED heads.



## WARNING

### Quick rise hazard

Do not operate shelf release lever without Scanner in place.



*The stand includes hydraulics for moving the scanner shelf up and down. Use extreme caution.*

**NEVER ATTEMPT TO RAISE OR LOWER THE SHELF WITHOUT THE SCANNER BOLTED TO IT. WITHOUT THE WEIGHT OF THE SCANNER ON IT, THE SHELF COULD RISE RAPIDLY WHEN RELEASED, POTENTIALLY CAUSING SEVERE INJURY.**

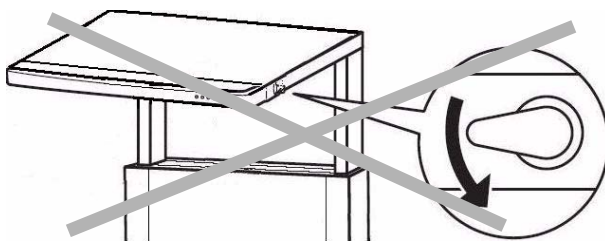

1. Place one hand firmly on the front handle (1) of the scanner shelf, then carefully press the release handle (2) so that the shelf lifts out of the way.

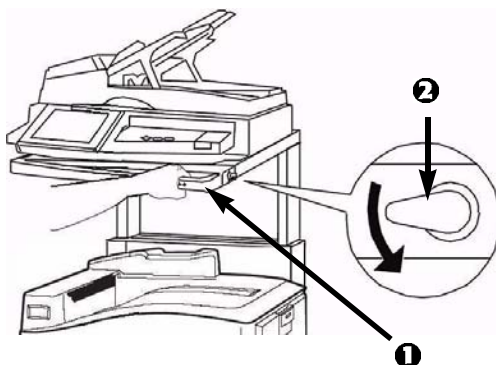

2. With an LED lens cleaner or soft cloth, gently wipe each of the four heads (1). Move the cleaner as shown, using a clean section of the cleaner with each pass. Be careful not to damage the guards (2).

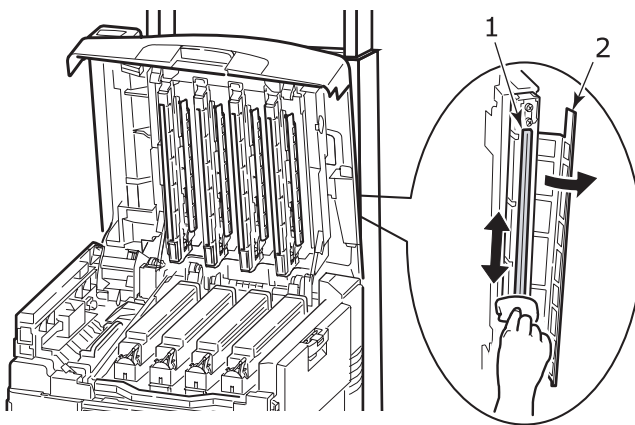



**TO PREVENT ANY POSSIBLE CRUSHING OF FINGERS, KEEP YOUR HANDS AWAY FROM THE POSTS AT THE BACK OF THE SCANNER STAND WHEN MOVING THE SCANNER SHELF DOWN.**

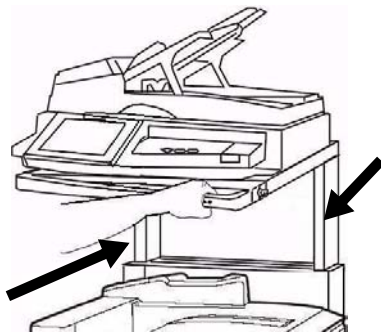

3. Place one hand firmly on the front handle of the scanner shelf, then press the release handle and carefully lower the scanner shelf, making sure it locks in place.

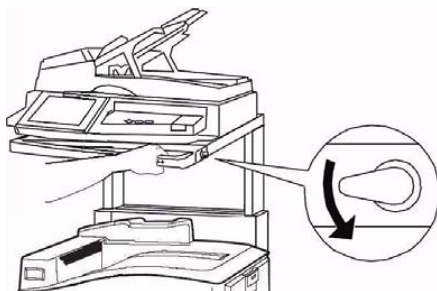

## Cleaning the paper feed rollers

Clean the paper feed rollers if paper jams frequently occur.

1. Remove items like a wrist watch or bracelet then use the **Shutdown/Restart** button followed by the **On/Off** switch to turn the printer unit off.

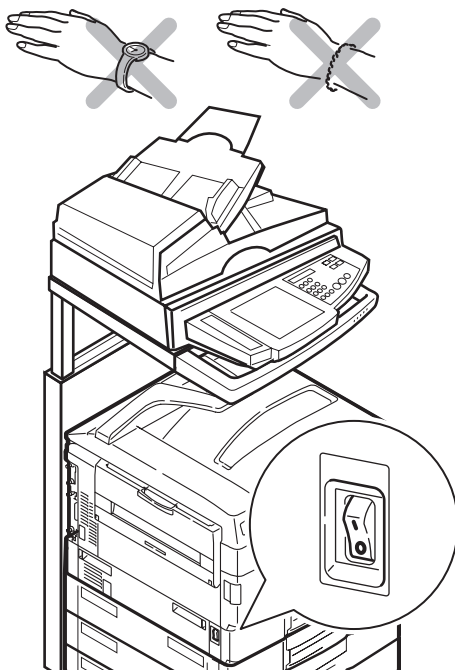

2. Open Tray 1 side cover and pull out the paper guide plate (1).

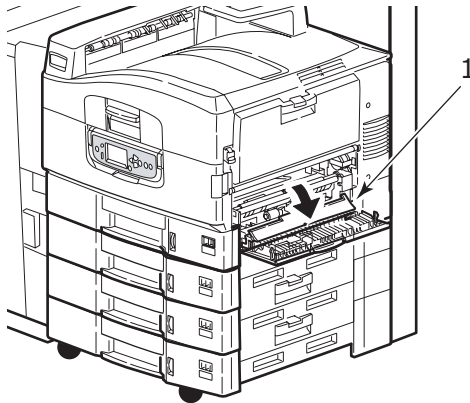

3. Remove Tray 1 completely from the printer unit.

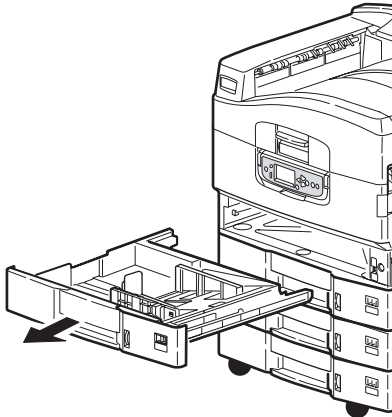

4. Gaining access through the gap left by Tray 1, wipe the 3 paper feed rollers (2) with a soft cloth lightly moistened with water.

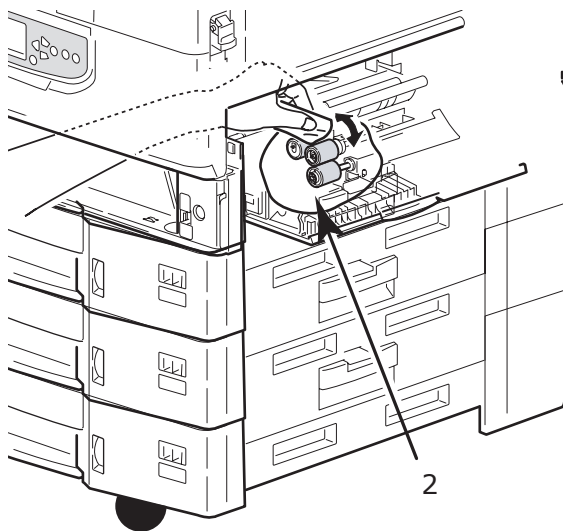

5. Replace Tray 1.

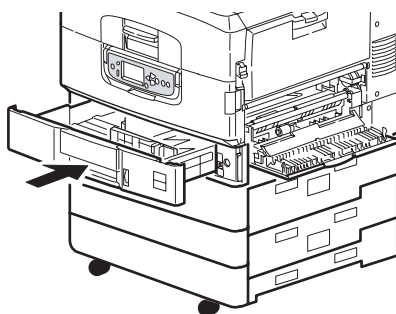

6. Return the paper guide plate to its original position and close Tray 1 side cover.



7. Turn on the printer unit.

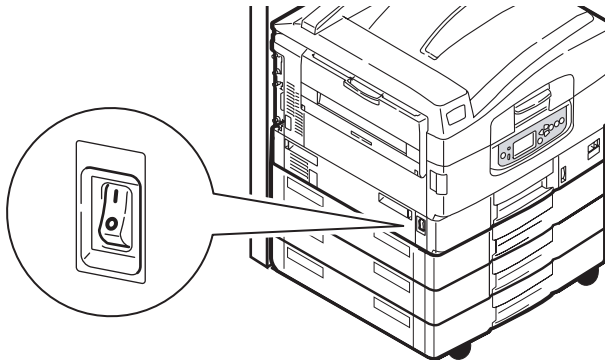

## Cleaning the printer unit casing

1. Turn the printer unit off by using the **Shutdown/Restart** button followed by the **On/Off** switch.

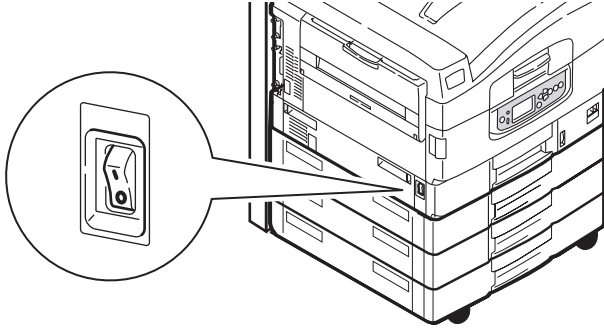

2. Wipe the printer unit surface with a soft cloth moistened sparingly with water or neutral detergent.

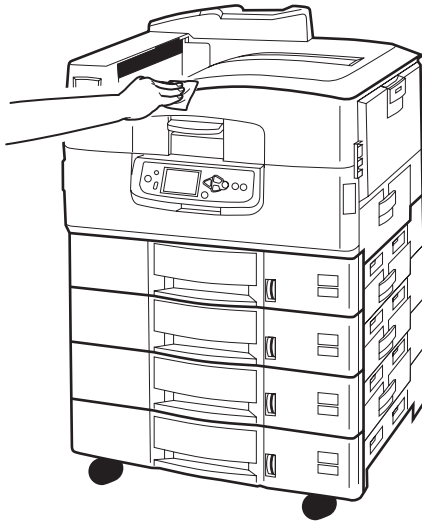

3. Use a soft dry cloth to dry the printer unit surface.

4. Turn on the printer unit.

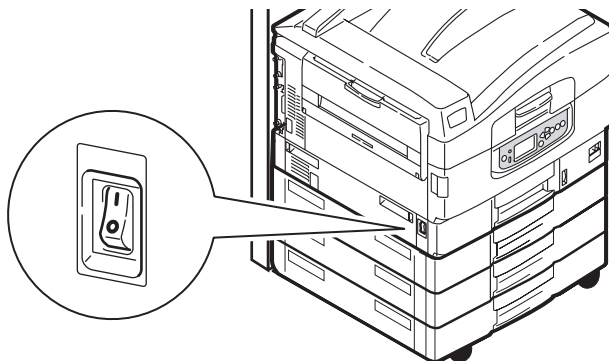

### Emptying the punch chip box (Punch unit optional accessory)

When the display panel indicates that the punch chip box is full, empty the box as follows:

1. Operate the Finisher lever and move the Finisher away from the printer unit.

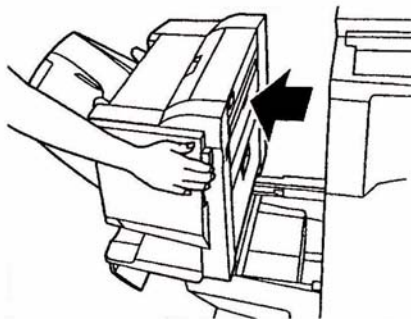

2. Pull out the punch chip box, being careful to keep it level so as not to spill any chips.

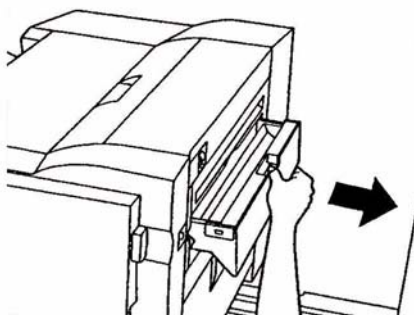

3. Discard the chips in an appropriate place.



4. Replace the punch chip box carefully into the Finisher.

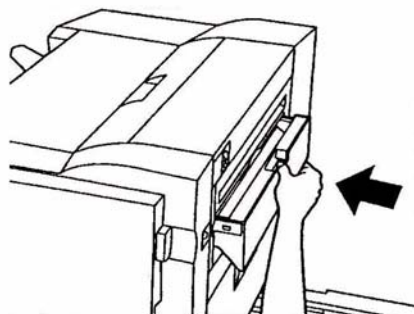



5. Check that the punch chip box has been replaced correctly then move the Finisher back into position, being careful not to trap your fingers.

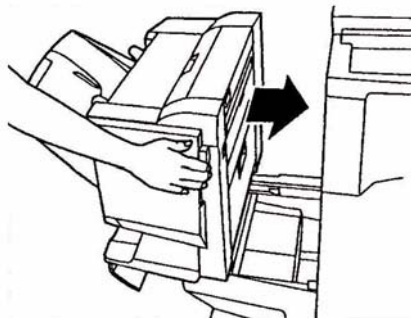

# Maintenance – scanner unit

## Cleaning the ADF

From time to time the pad assembly and feed rollers may become contaminated with ink, toner particles or paper dust. In this case the scan module may not feed documents smoothly. If this occurs, follow the cleaning procedure below.

The stand includes hydraulics for moving the scanner shelf up and down.



*The stand includes hydraulics for moving the scanner shelf up and down. Use extreme caution.*

**NEVER ATTEMPT TO RAISE OR LOWER THE SHELF WITHOUT THE SCANNER BOLTED TO IT. WITHOUT THE WEIGHT OF THE SCANNER ON IT, THE SHELF COULD RISE RAPIDLY WHEN RELEASED, POTENTIALLY CAUSING SEVERE INJURY.**

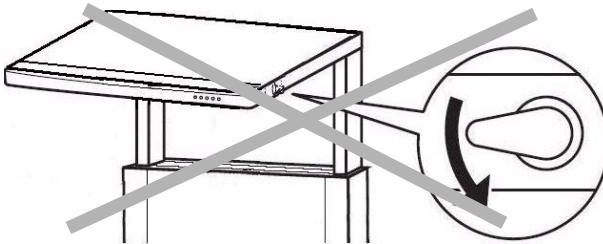

**TO PREVENT ANY POSSIBLE CRUSHING OF FINGERS, KEEP YOUR HANDS AWAY FROM THE POSTS AT THE BACK OF THE SCANNER STAND WHEN MOVING THE SCANNER SHELF DOWN.**

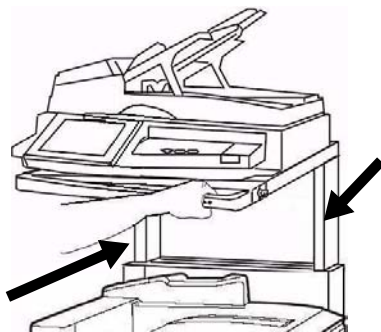

1. Moisten a cotton swab with isopropyl alcohol (95%).
2. Press down the ADF release button (1) and open the ADF front cover (2).

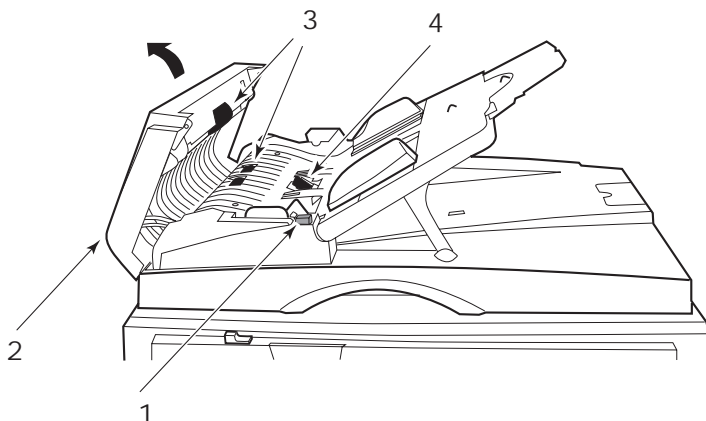

3. Wipe the feed rollers (3) by moving the swab from side to side.

4. Rotate the rollers forward with your finger and repeat Step 3 until the rollers are clean. Be careful not to snag or damage the springs near the pad (4).
5. Wipe the pad (4) from top to bottom, being careful not to hook the springs.
6. Close the ADF front cover (2).

Your machine is now ready to use.

## **Cleaning the Touch Screen Display**

1. To clean the display surface, use a soft cloth, either dry or moistened with neutral detergent or ethanol. Do not use any organic solvents, acid or alkali solutions.

## Cleaning the document glass

The document glass needs to be cleaned occasionally to ensure optimum image quality and performance.

Clean the glass as follows.

1. Open the document cover (1).

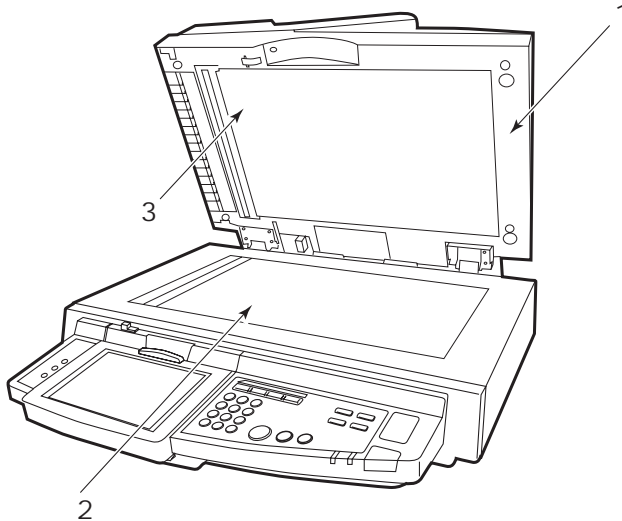

2. Moisten a soft, clean cloth with isopropyl alcohol (95%).
3. Gently wipe the document glass (2) and the white sheet (3) on the lower side of the document cover to remove dust or any toner particles.
4. Close the document cover (1).

Your machine is now ready for use.

## Replacing the snap-in pad module

After scanning approximately 100,000 pages through the ADF, the pad may become worn and you may experience problems with document feeding. In this case, you are recommended to replace the pad module by a new one.

Replace the pad module as follows.

### Removing the snap-in pad module

1. Press down the ADF release button (1) and open the ADF front cover (2).

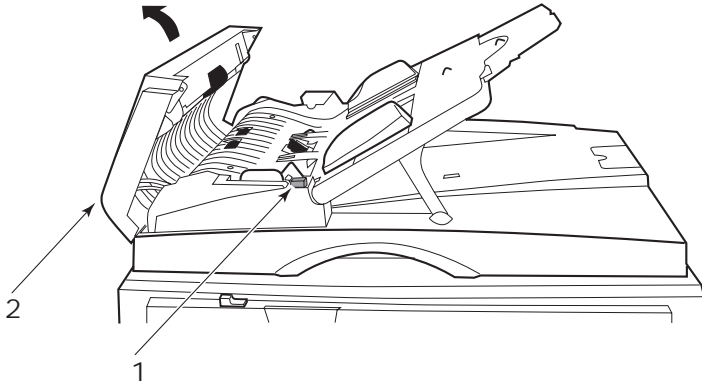

2. Press both arms of the ADF snap-in pad module inward with your fingers and pull out the ADF snap-in pad module.

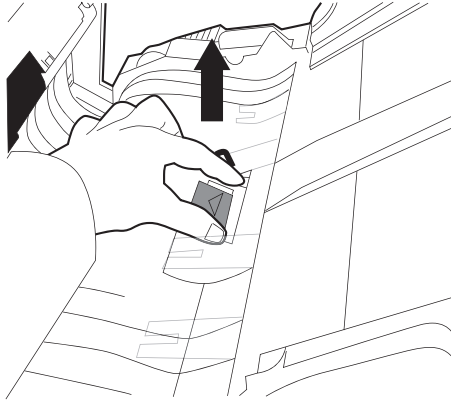

### **Inserting a new snap-in pad module**

1. Remove the new snap-in pad module from its box.
2. Press both arms of the snap-in pad module (2) inward using two fingers.

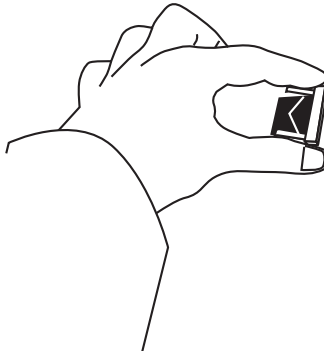

- 3.** Push the snap-in pad module into the hole until it snaps into place.

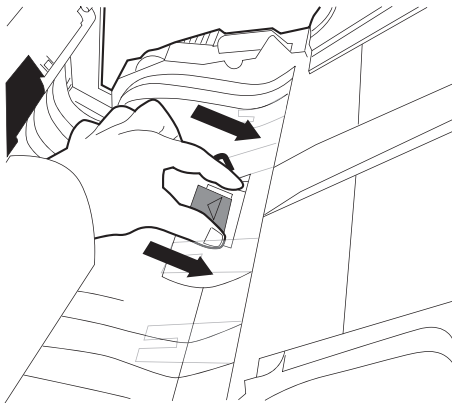



## Optional accessories

This section describes optional accessory equipment for your MFP. The following accessories are available:

- > Finisher (for stapling or saddle stitching printer output)
- > Punch unit (to extend Finisher functionality)

### Accessory order information

Item	Order number
Finisher: 4-tray	42940201
Finisher Punch Unit: 2-3 hole	42872902

### Installing accessories

*NOTE*

*The Finisher and Punch unit must be installed by an authorized engineer.*

For the following accessories, you have to make the appropriate setting in your printer driver(s):

- > Punch unit
- > Finisher

Refer to the Printing Guide for driver setting details.

# Troubleshooting

## General

If the printer unit display panel does not display anything or is still in standby mode 10 minutes after switching on, follow the printer unit shutdown sequence to switch it off. Check all cable connections before restarting the printer unit. If the problem persists, contact your dealer.

## Networking

The majority of networking troubleshooting is dealt with in the Fiery Configuration Guide. For specific troubleshooting on e-mail and LDAP server problems, refer to ["Appendix G- Troubleshooting \(network\)" on page 205](#).

## Paper jams

This section provides information to help you deal with problems that may arise when using the MFP. The following paragraphs describe actions to take in the event of a paper jam and how to deal with unsatisfactory print results. Display panel messages about paper jams and relevant actions are given in this section while a list of other typical messages and suggested responses is given in ["Appendix A – Display Panel Messages \(Printer unit\)" on page 167](#).

## Paper jams – printer unit

If a paper jam occurs, a message appears on the display panel in the printer unit Control Panel. You can press the Help button to display guidance on how to clear the jam.

For full details of clearing jams, refer to the following paragraphs, which correspond to the paper jam messages.

## Open cover, paper jam, tttttt side cover

Tray 1, or any one of Tray 2 to Tray 4, can appear in place of the tttttt characters in the display panel message. In this example Tray 1 is used, the procedure being similar for all other trays.

1. Squeeze the catch (1) on Tray 1 side cover and open the cover.

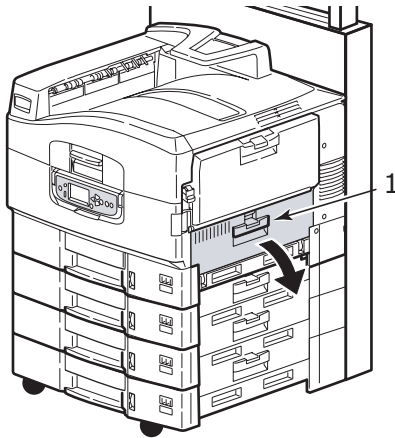

2. Holding it by the tab (2), turn the paper guide outward.

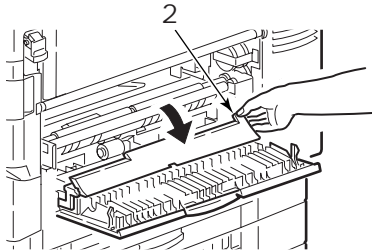

3. Carefully remove the jammed paper.

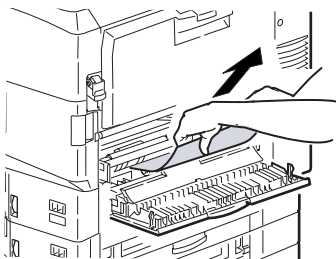

4. Put the paper guide back into position and close Tray 1 side cover.

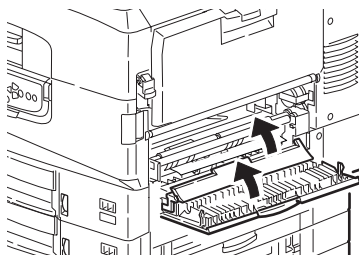

## Open cover, paper jam, side cover

1. If the MP Tray is open, close it so that the side cover (1) is visible.

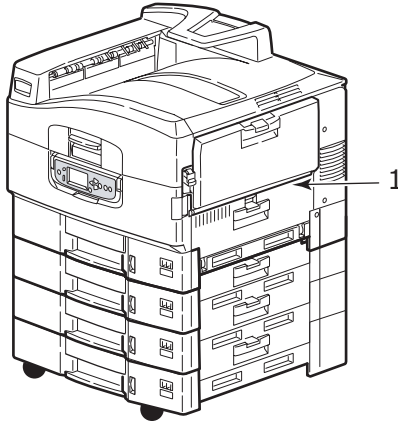

2. Pull the release lever (2) and pull open the side cover.

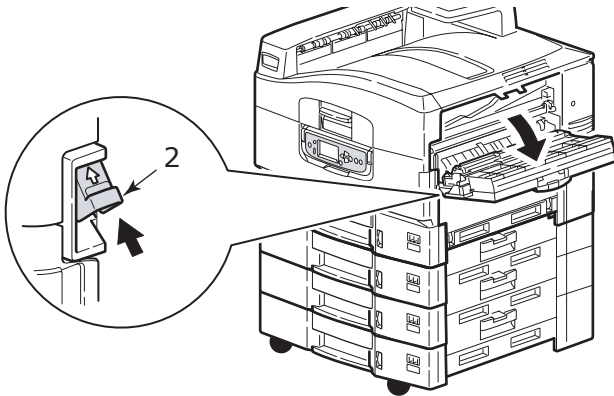

3. Carefully remove the jammed paper.

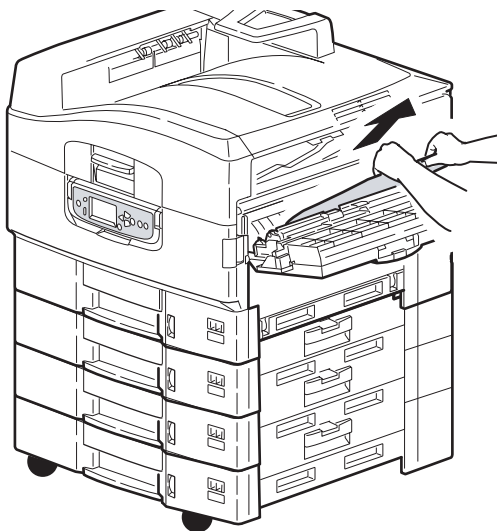

4. Close the side cover.

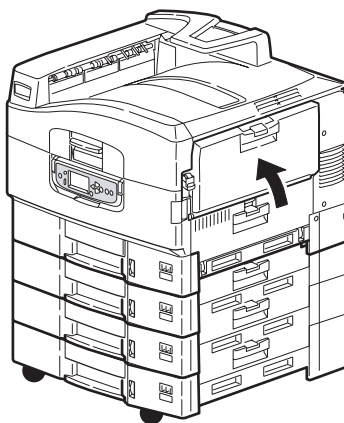

## Open cover, paper jam, top cover

<p><b>! WARNING</b></p> <p><b>Quick rise hazard</b> Do not operate shelf release lever without Scanner in place.</p>	
--	---

*The stand includes hydraulics for moving the scanner shelf up and down. Use extreme caution.*

**NEVER ATTEMPT TO RAISE OR LOWER THE SHELF WITHOUT THE SCANNER BOLTED TO IT. WITHOUT THE WEIGHT OF THE SCANNER ON IT, THE SHELF COULD RISE RAPIDLY WHEN RELEASED, POTENTIALLY CAUSING SEVERE INJURY.**



1. Place one hand firmly on the front handle (1) of the scanner shelf, then carefully press the release handle (2) so that the shelf lifts out of the way.

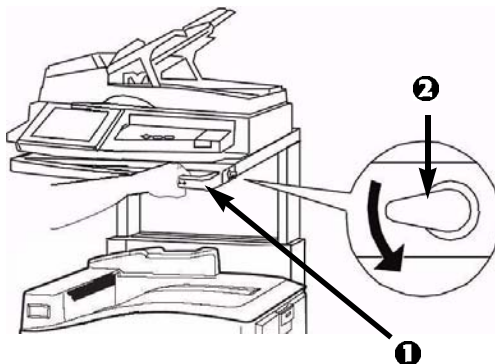

2. Squeeze the basket handle (2) and raise the drum basket.

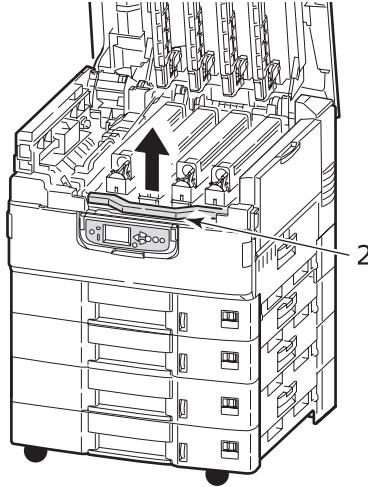

3. Carefully remove any paper on the belt.

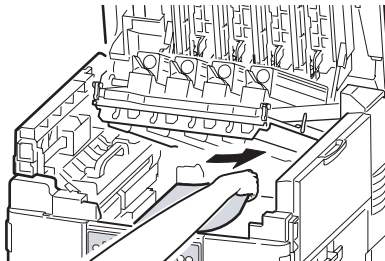

4. If paper is jammed in the fuser unit, push the lock lever (3) in the direction shown to release the unit.





### IMPORTANT!

**The fuser will be hot after printing! Allow the fuser to cool for 10 minutes before removing any jammed paper.**

Holding the fuser unit (4) by the handle, lift it out of the printer unit and place it on a flat surface.

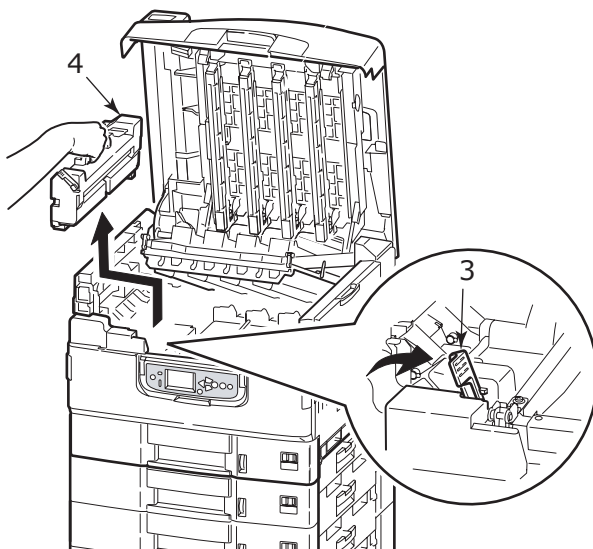

5. Pull up the jam release levers (5) and remove the jammed paper.

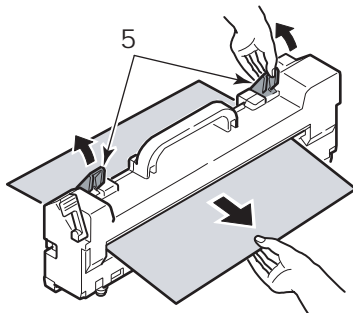

6. Carefully replace the fuser unit into the printer unit and turn the lock lever (6) in the direction shown to lock the fuser unit.

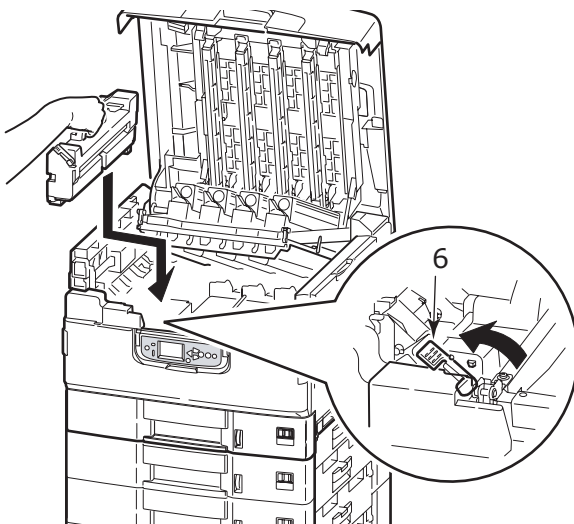

7. If paper is jammed near the paper exit, open the face-up stacker (7).

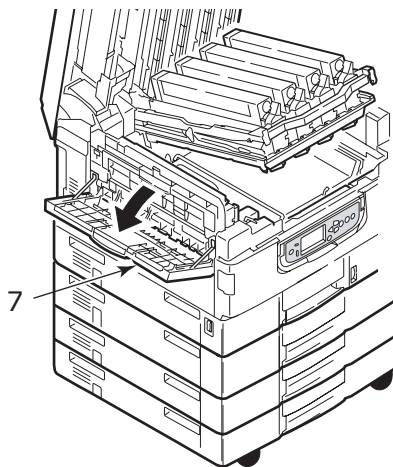

8. Open the side cover (paper exit) (8) and remove the jammed paper.

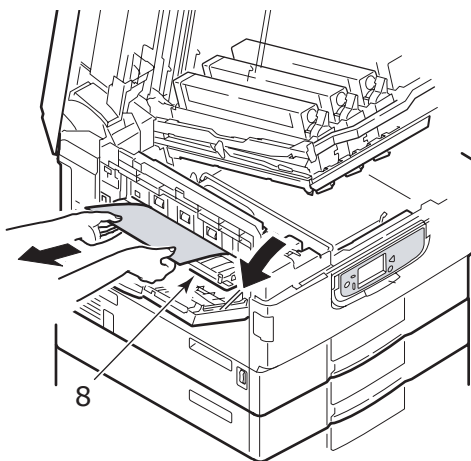

9. Close the side cover (paper exit) and then the face-up stacker.

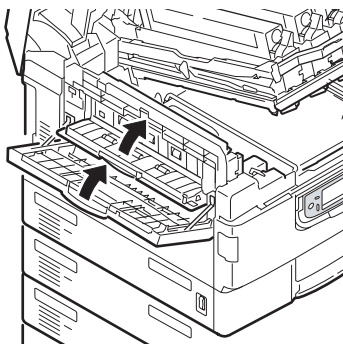

10. Return the image drum basket (9) into position and check it is locked.

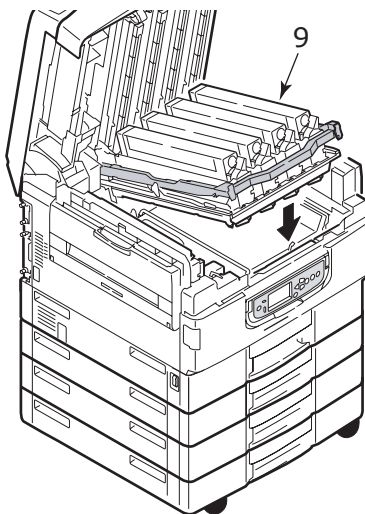

11. Close the printer unit top cover and ensure it is latched.

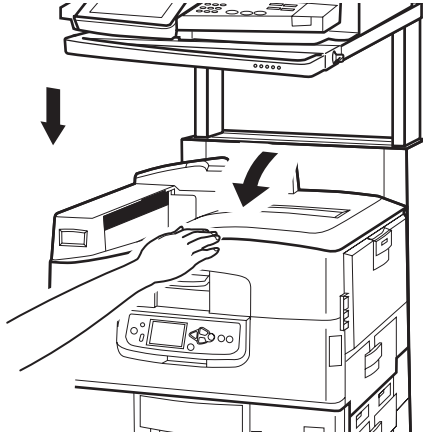

**TO PREVENT ANY POSSIBLE CRUSHING OF FINGERS, KEEP YOUR HANDS AWAY FROM THE POSTS AT THE BACK OF THE SCANNER STAND WHEN MOVING THE SCANNER SHELF DOWN.**

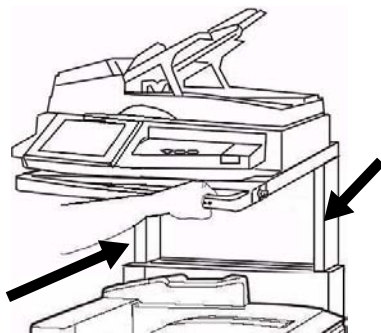

- 12.** Place one hand firmly on the front handle (1) of the scanner shelf, then carefully press the release handle (2) and carefully lower the scanner shelf, making sure it locks into place.

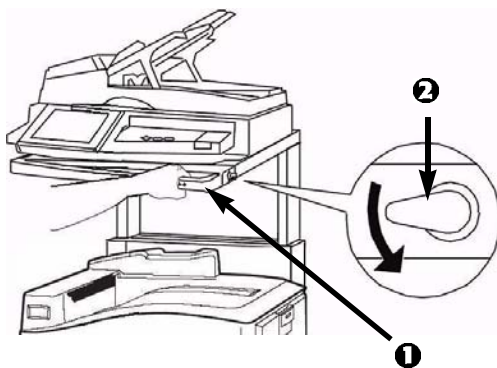

## Paper jams – duplex unit

### Check duplex unit, paper jam

1. If a Finisher unit is attached to your printer unit, operate the lever (1) of the Inverter unit to separate the Inverter from the printer.

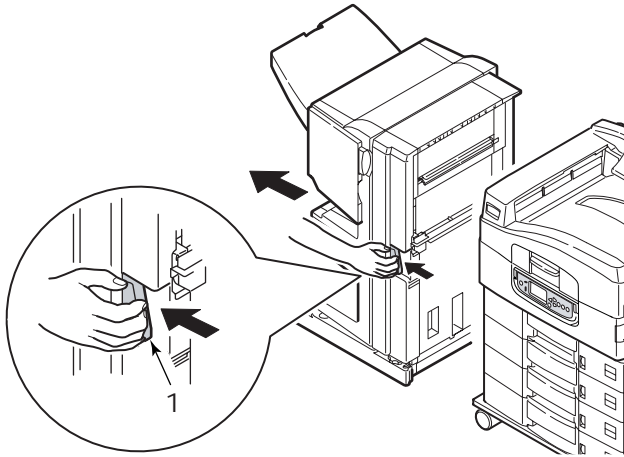

2. Operate the duplex cover release button (2) and open the cover.

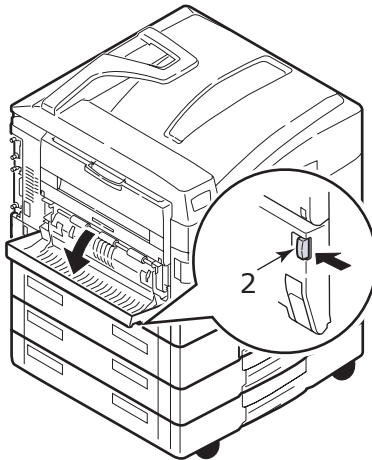

3. Carefully remove any jammed paper then close the cover.

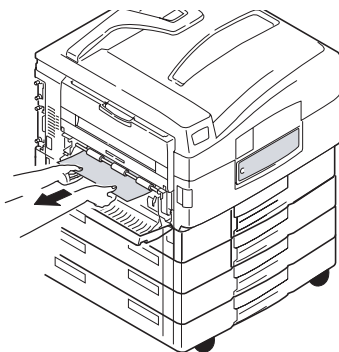

4. Operate the levers (3) and pull out the duplex unit.

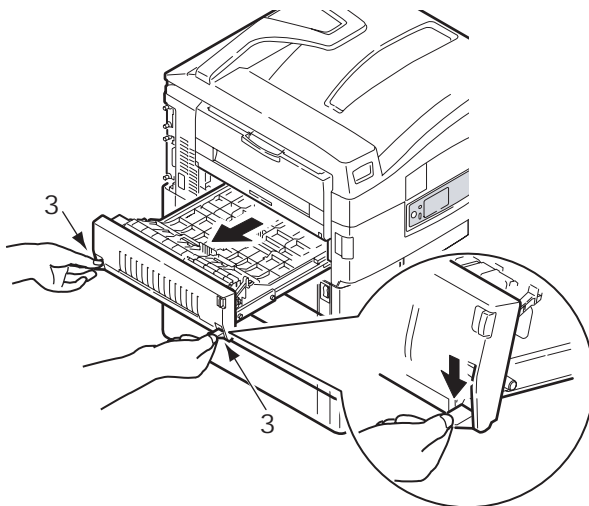



5. Holding the front top cover by the grip (4), push it gently inwards and raise it.

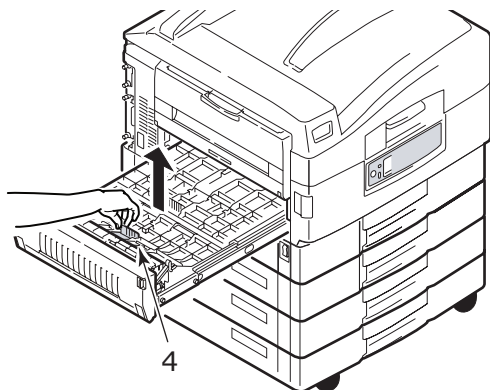

6. Remove any jammed paper.

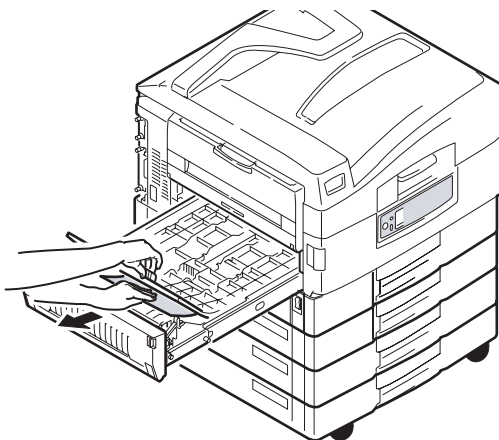

7. In similar manner, check for and clear any paper jammed under the rear top cover.



8. Replace the two top covers.

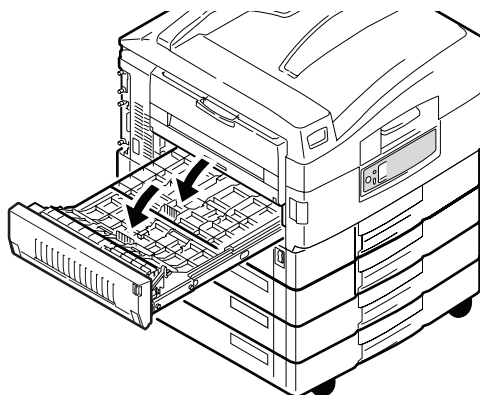

- 9.** Push the duplex unit back into position.

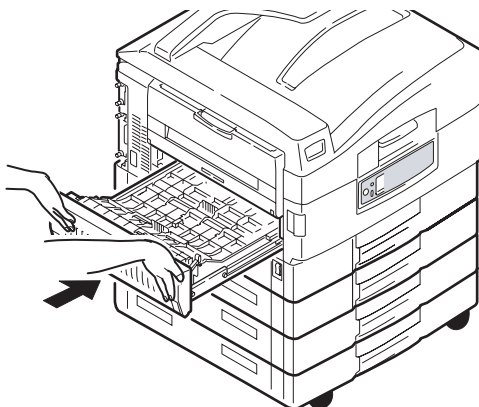

- 10.** If you detached a Finisher unit to gain access to the duplex unit, replace the Finisher unit.

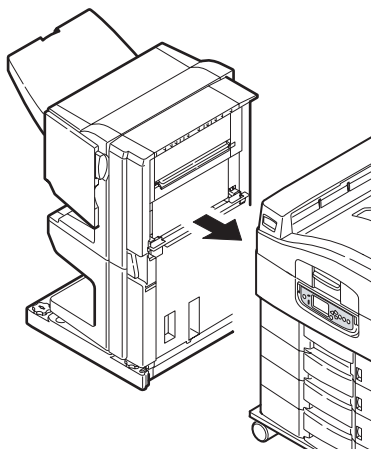

## Paper jams – Finisher (optional accessory)

### Check Finisher, paper jam/paper remains

Use the **Help** button on the printer unit control panel to check the number displayed. You will need this to be able to clear the paper jam. The following paragraphs explain what to do for each of the indicated numeric codes.

### 591, 592, 593, 599/ 643, 645 (paper jam around Finisher)

1. Remove any paper at the Finisher paper exit.

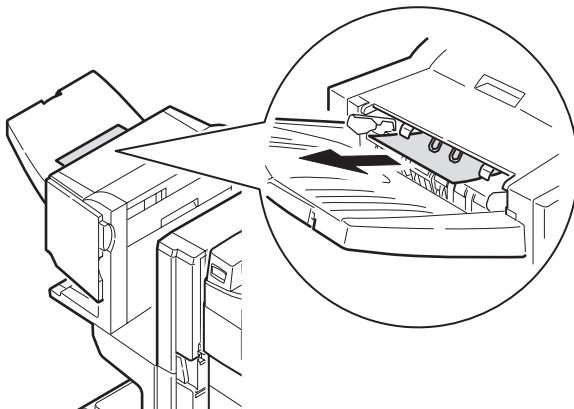

2. Operate the Finisher lever (1) and move the Finisher away from the Inverter.

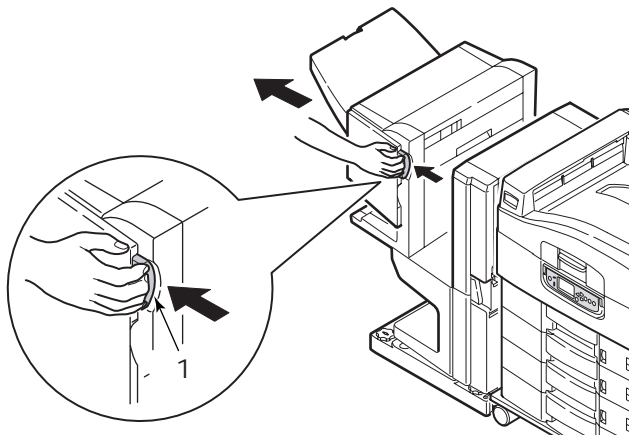

3. Open the Finisher top cover.

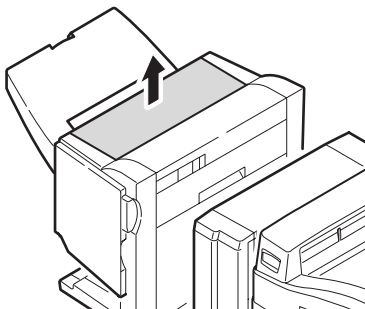

4. Carefully remove any jammed paper.

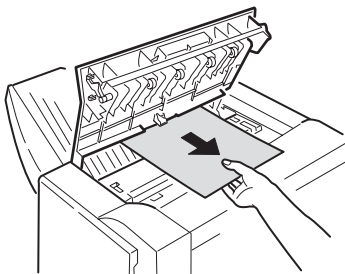

5. Close the Finisher top cover.

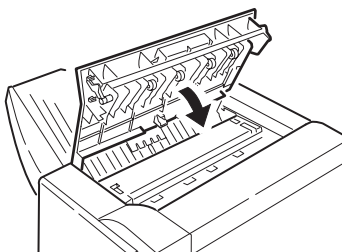

6. Move the Finisher back into position and connect it to the Inverter.

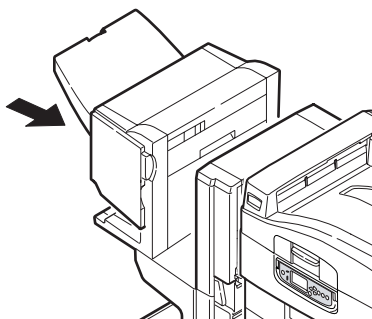

### **594, 597, 598/ 644, 646 (paper jam in Finisher)**

1. Operate the Finisher lever (1) and move the Finisher away from the Inverter.

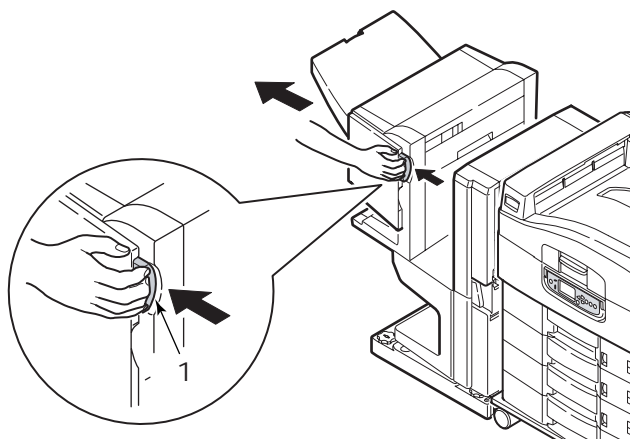

2. Open the Finisher front cover (2).

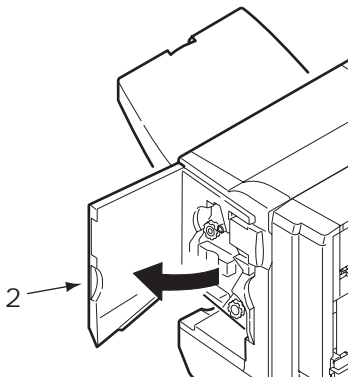

3. Continue to turn the lower knob (3) clockwise until any jammed paper is completely ejected.

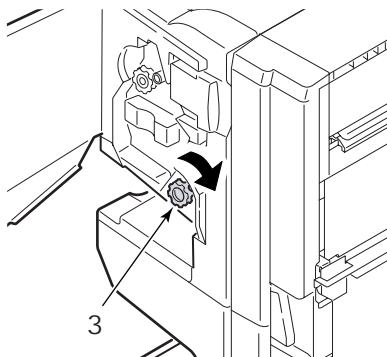



4. Remove the ejected paper.

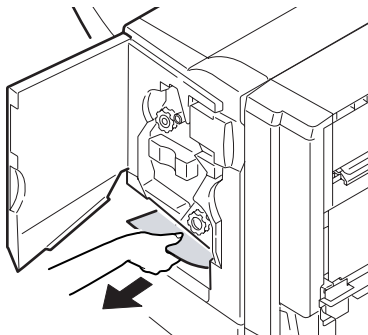

5. Close the Finisher front cover.

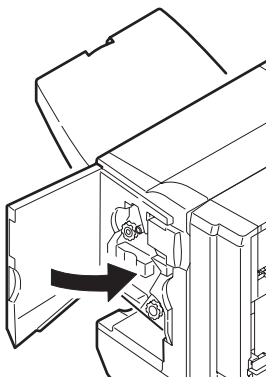

6. Open the Finisher right side cover.

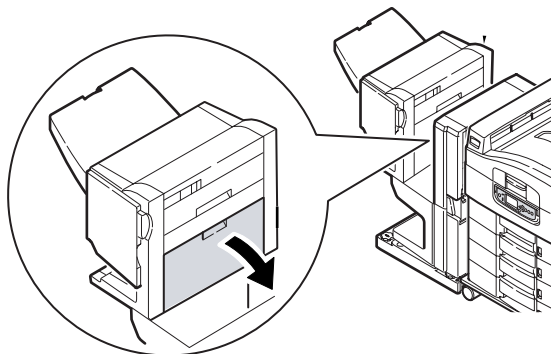

7. Carefully remove any jammed paper.

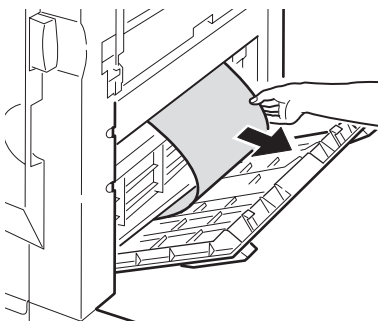

- 8.** Close the Finisher right side cover.

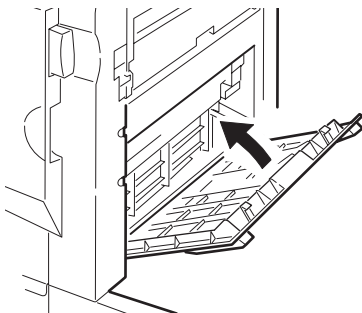

- 9.** Move the Finisher back into position and connect it to the Inverter.

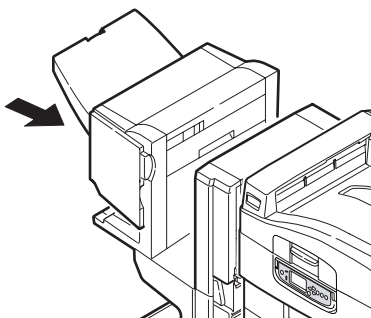

## 590 (paper jam in Finisher/Punch unit)

1. Operate the Finisher lever (1) and move the Finisher away from the Inverter.

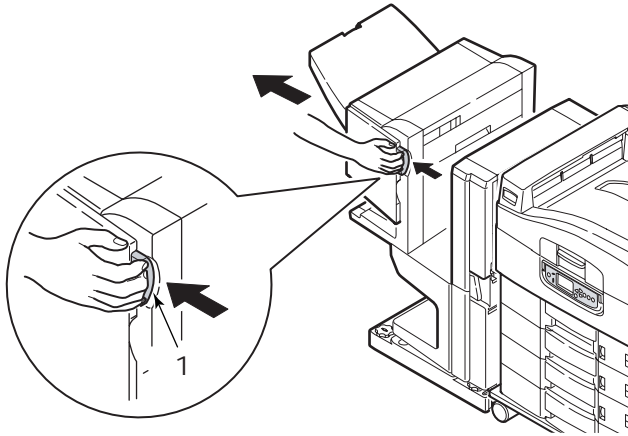

2. Move the tab (2) on the right side of the Finisher to align it with the mark (3).

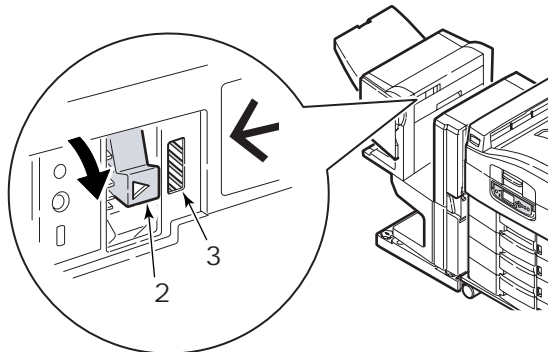

3. Open the Finisher top cover.

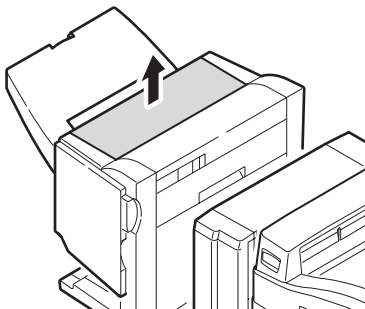

4. Carefully remove any jammed paper.

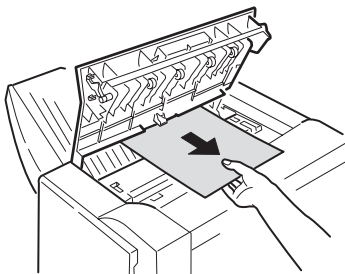

5. Close the Finisher top cover.

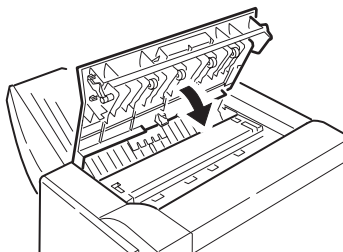

6. Move the Finisher back into position and connect it to the Inverter.

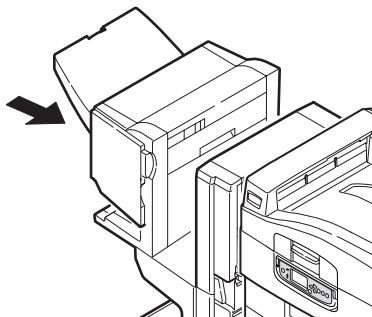

### Check Inverter, paper jam

1. Operate the Finisher lever (1) and move the Finisher away from the Inverter.

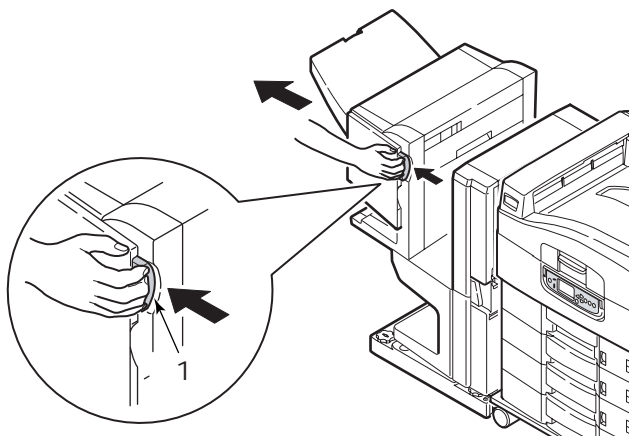

2. Squeeze the recessed handle (2) and open the left side cover of the Inverter.

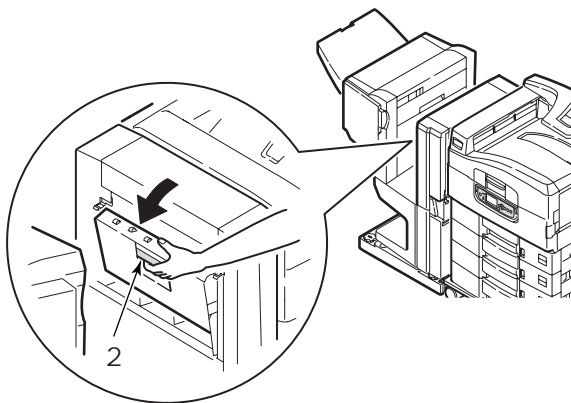

3. Carefully remove any jammed paper.

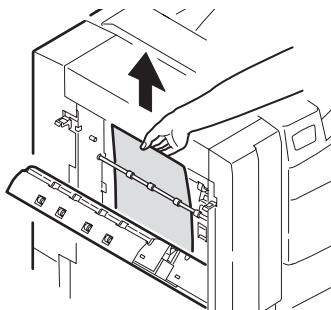

4. Close the Inverter left side cover.

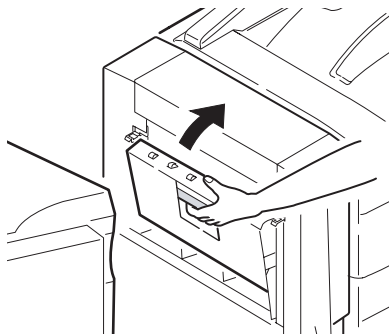

5. Move the Finisher back into position and connect it to the Inverter.

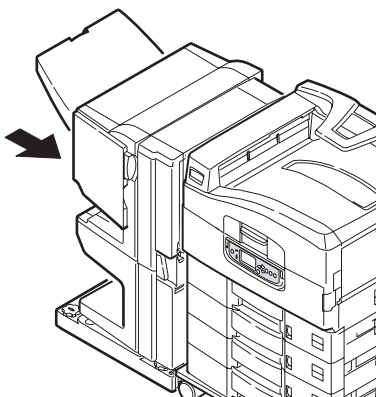



6. Operate the Inverter lever (3) and separate the Inverter from the printer.

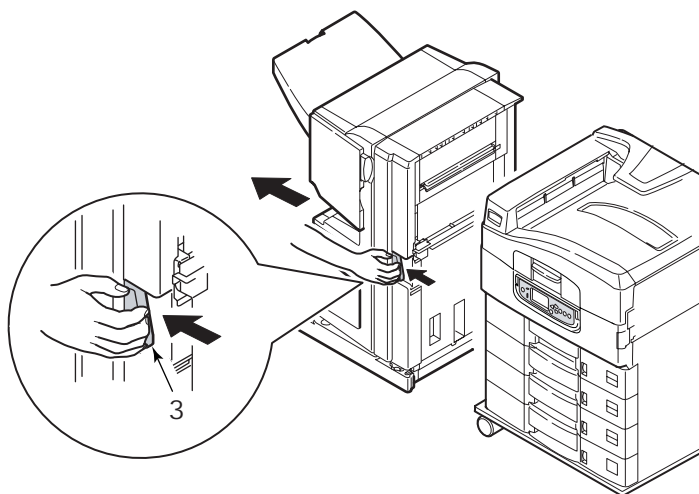

7. Open the right side door (4) of the Inverter.

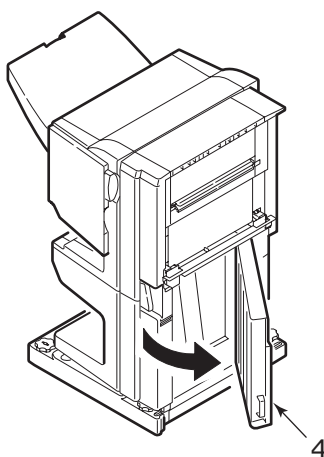

- 8.** Remove any jammed paper.

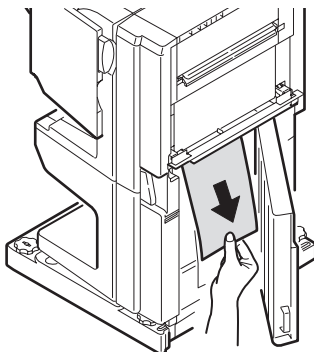

- 9.** Close the right side door.

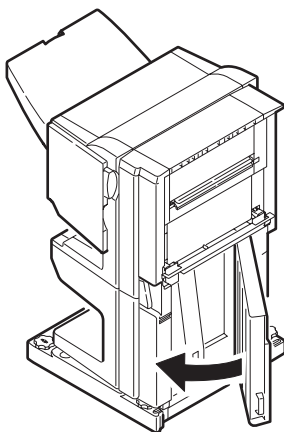

10. Move the Finisher and Inverter back into position and connect to the printer unit.

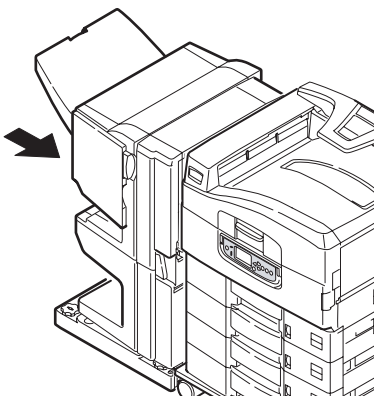

## Avoiding printer unit paper jams

The following table summarizes possible causes of paper jams and suggests ways of avoiding them.

<b>Possible cause</b>	<b>Suggested remedy</b>
The printer unit is not level.	Ensure the printer unit is level.
Your print media is too light or too heavy.	Use appropriate media.
Your print media is damp or charged with static electricity.	Use media that has been stored in appropriate temperature and humidity conditions.
Your print media is creased or curled.	Use appropriate media. Decurled media can be used.
Your print media sheets are not aligned with each other.	Remove the sheets, jog them into alignment and reload them.
Your print media is not aligned properly in the paper tray.	Adjust the paper stop and paper guides of the tray, or the manual feed guide on the MP Tray to align the media properly.
Your envelopes to be printed are not oriented properly.	Adjust the orientation as required.
Your printer unit feed roller is dirty.	Wipe the roller with a cloth moistened with water.
Your printer unit feed rollers are wearing out.	Replace the feed rollers.
The media weight or type have been wrongly set.	Select the correct printer menu settings for [Media Weight] and [Media Type].

## Dealing with unsatisfactory printing

Symptoms	Possible causes	Steps to take
Vertical white lines can be seen on the printed page.	The LED head is dirty.	Wipe the LED head with a LED lens cleaner or with a soft cloth.
	The toner is low.	Replace the toner cartridge.
	Foreign materials may be present in the image drum.	Replace the image drum cartridge.
	Light-shielding film of the image drum cartridge is dirty.	Wipe the film with a LED lens cleaner or with a soft cloth.
Printed images are fading vertically.	The LED head is dirty.	Wipe the LED head with a LED lens cleaner or with a soft cloth.
	The toner is low.	Replace the toner cartridge.
	The paper is not suitable for the printer unit.	Use recommended paper.
Printing is light.	The toner cartridge is not properly seated.	Reinstall the toner cartridge.
	The toner is low.	Replace the toner cartridge.
	The paper is moist.	Use paper stored in proper temperature and humidity conditions.
	The paper is not suitable for the printer unit.	Use recommended paper.
	Thickness and type of paper are inappropriate.	Set a proper value for [Media Weight] and [Media Type] in the menu setup, or set one value thicker for [Media Weight].
	Recycled paper is being used.	Set one value thicker for [Media Weight] in the menu setup.
Partially faded images. White spots and lines appear in solid printing.	Paper is moist or dry.	Use paper stored in proper temperature and humidity conditions.

Symptoms	Possible causes	Steps to take
Vertical lines appear.	The image drum cartridge is damaged.	Replace the image drum cartridge.
	The toner is low.	Replace the toner cartridge.
Horizontal Lines and spots appear periodically.	When the interval is about 94mm (4in), the image drum (the green tube) is damaged or dirty.	Wipe it lightly with a soft cloth. Replace the image drum cartridge when it is damaged.
	When the interval is about 42mm (1.5in), there may be foreign particles in the image drum cartridge.	Open/close the top cover, and print again.
	When the interval is about 87mm (3.5in), the fuser unit is damaged.	Replace the fuser unit.
	The image drum cartridge has been exposed to light.	Replace the image drum cartridge if the problem is not resolved.
White area of paper is lightly stained.	Paper contains static.	Use paper stored in proper temperature and humidity conditions.
	Too thick paper is used.	Use thinner paper.
	The toner is low.	Replace the toner cartridge.
Periphery of the letters is smudged.	The LED head is dirty.	Wipe the head with LED lens cleaner or with a soft cloth.
Toner comes off when it is rubbed.	The thickness and type of the paper are incorrectly set.	Set the correct value of [Media Type] and [Media Weight] in the menu setup or set one value thicker for [Media Weight].
	Recycled paper is used.	Set one value thicker for [Media Weight] in the menu setup.
Glossiness is not uniform.	The thickness and type of the paper are incorrectly set.	Set the correct value of [Media Type] and [Media Weight] in the menu setup or set one value lighter for [Media Weight].

## Paper jams – ADF

To clear a paper jam in the ADF:

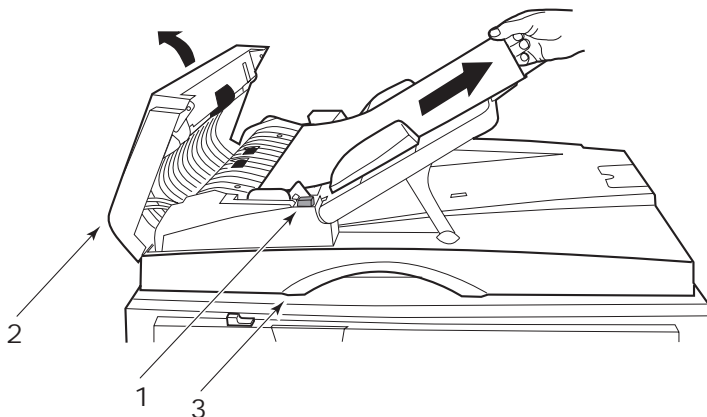

1. Press down the ADF Release button (1).
2. Gently open the ADF front cover (2).
3. Carefully pull the paper out of the ADF.
4. If there is paper jammed at the ADF exit area, open the ADF document cover, operate the coloured release lever situated on the underside of the cover at (3) and carefully pull out the jammed paper. Close the document cover.
5. Close the ADF front cover.
6. Ensure that all jammed paper has been totally removed before proceeding.

### NOTE

*In the event of an ADF paper jam, as with an ADF cover open error, Flatbed cover open error or Hard disk full error, the current scan/copy job will be cancelled.*

## Dealing with unsatisfactory copying results

As well as the suggestions provided in ["Dealing with unsatisfactory printing" on page 157](#), ensure that the scanner unit glass is clean at all times.

## Staple jams – Finisher (optional accessory)

### Check Finisher, Staple Jam

When the printer unit display indicates a staple jam has occurred, clear the jam as follows:

1. Open the Finisher front cover.

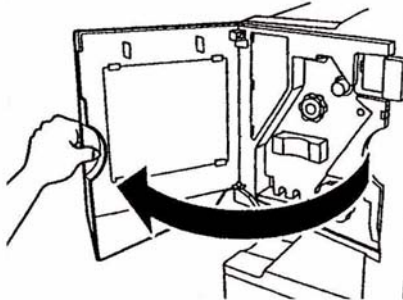

2. Turn the knob in the direction indicated until the colored indicator appears.

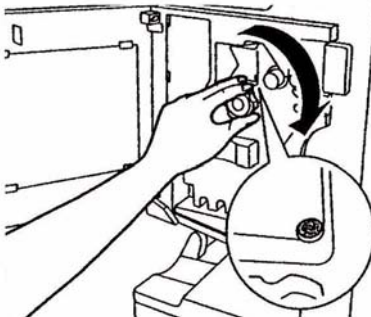



3. Remove any paper that awaits stapling in the paper ejection area.

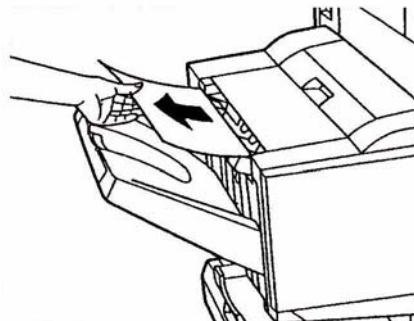

4. Pull out the staple unit.

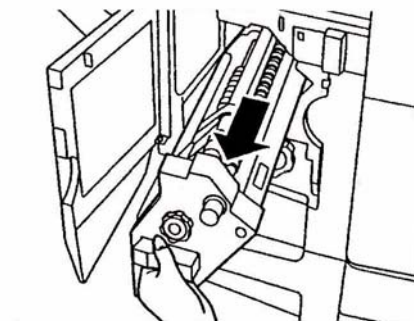

5. Turn the knob in the direction indicated to move the stapler to the front.



6. Grip both sides of the staple cartridge, pull it up and remove it.

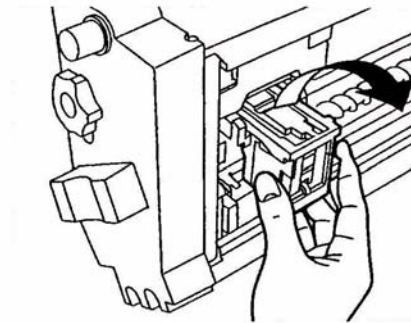

7. Raise the staple cartridge gate.

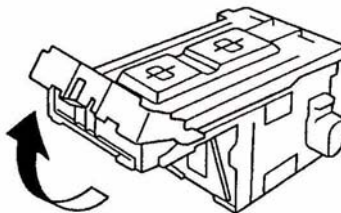

- 8.** Remove all staples that are emerging from the staple case.

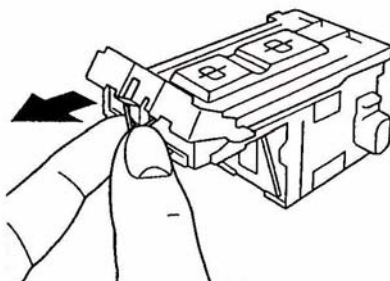

- 9.** Return the staple cartridge gate to its original position.

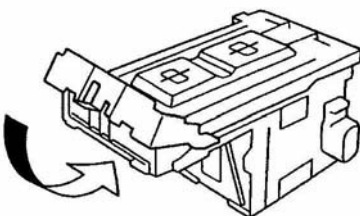

- 10.** Replace the staple cartridge.

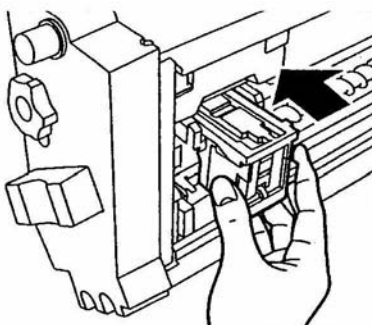

- 11.** Ensure that the staple cartridge is securely installed back into the staple unit then push the staple unit fully home.

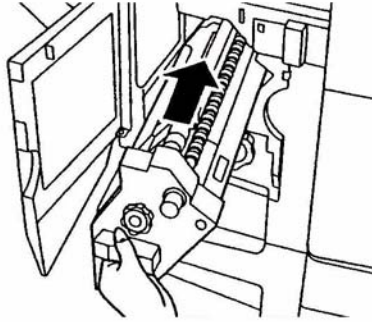

- 12.** Close the Finisher front cover, being careful not to trap your fingers.

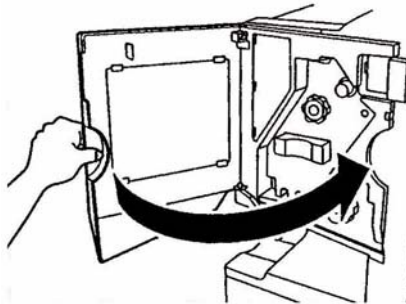

# Specifications

## Printer unit

Item	Specification
Dimensions	25.8x24.4x18.2 in (WxDxH) 655x620x462 mm (WxDxH)
Weight	Without options, 152 lb (68 kg)
Print speeds	36 ppm color; 40 ppm monochrome 20 – 28 lb paper
Resolution	1200 x 1200 dpi
Emulations	PCL 5c, PCL XL 2.1, PS
Memory	1 GB standard
Paper input at 20 lb (75 g/m <sup>2</sup> )	Trays 1 – 4: 530 sheets Letter each MP Tray: 230 sheets Letter
Paper weight	17 – 71 lb (64 – 268 g/m <sup>2</sup> )
Paper output	Face-down stacker: 500 sheets Face-up stacker: 250 sheets
Interfaces	Parallel, USB 2.0, 10Base-T and 100Base-TX
Duty cycle	150,000 pages/month maximum
Toner life	15,000 Letter pages @ 5% coverage
Image drum life	30,000 Letter pages
Belt life	100,000 Letter pages
Fuser life	100,000 Letter pages
Waste toner bottle life	30,000 Letter pages
Power rating	110 – 127 VAC, 60 Hz 230 VAC, 50 Hz +/- 2Hz
Power consumption	Operating: 1,500 W maximum, 750 W typical Standby: 1,300 W maximum, 200 W typical Power save: <45 W
Operating environment	Operating: 50 – 90°F/20 – 80%RH Off: 32 – 110°F/10 – 90%RH

Item	Specification
Noise level	Operating: 53dBA maximum Standby: 40dBA maximum Power save: 40dBA maximum after 30 mins background level Machine Noise Information Ordinance 3. GSGV 18.1.1991: The maximum sound pressure level is equal to or less than 70dBA according to ISO 7779.

## Scanner unit

Item	Specification
Dimensions	22.9x27.3x15.4 in (WxDxH) (672x693x390 mm (WxDxH))
Weight	Including ADF: 51 lb (23 kg)
Power source (AC adapter)	Input: 100 – 240V, 50 –60Hz Output: 24V DC, 2.09A
Operating environment	Operating: 50 – 95°F/20 – 80%RH Off: -68 – 158°F/0 – 90%RH
Scanning speed (ADF)	35ppm/48ipm (300dpi greyscale/Letter/LEF)
Scanning area (ADF)	4x5 in to 11.8x17 in (10.2x12.8 cm to 29.9x43.2 cm)
Scanning area (glass)	0.5x5.5 in to 11.7x17 in (1.3x14 cm to 29.7x43.2 cm)
Warm-up time	<30secs
Optical resolution	600dpi
Imaging depth (input)	16 bit per color, 8 bit grayscale
Image processor RAM	128MB
ADF pad life	100,000 scan pages
ADF roller life	200,000 scan pages
ADF type	Duplex ADF
ADF capacity	<=50 sheets (16 – 28 lb (60 – 105 g/m <sup>2</sup> ))
Noise level	Flatbed scanning: <58dB ADF scanning: <58dB Standby: <45dB

# Appendix A – Display Panel Messages (Printer unit)

The display panel messages are intended to be self-explanatory. Representative messages are given as examples below.

Message	Comment
Ready to Print	Your printer unit is online and ready to print.
Printing tttttt	Your printer unit is printing and paper is currently being fed from tttttt, where tttttt identifies a tray.
tttttt Near End	The paper supply in the tray identified by tttttt will run out soon.
ccccc Toner Low	The remaining toner of color ccccc is running low.
Fuser Unit Near Life	The fuser unit is nearing the end of its working life.
Change Fuser Unit	The fuser unit has reached the end of its working life and has to be changed.
Inverter is Removed	The Inverter unit has been separated from the printer unit and all Finisher functions are disabled. (Finisher/Inverter is an optional accessory.)
Invalid Data Press ONLINE Button	Invalid data has been received by the printer. Press the ONLINE button to clear this warning.
Change Paper in tttttt mmmmmm pppppp Press ONLINE button Please see HELP for details	There is a mismatch between the media in the tray and print data. Load media of size mmmmmm and type pppppp into tray tttttt. The message may remain for some time after you have closed the tray. You can have the printer unit ignore this error for the current print job by pressing the ONLINE button. You can access help details by pressing the HELP button.
Install Paper tttttt mmmmmm Please see HELP for details	The printer unit has tried to take paper from an empty tray. Load media of size mmmmmm into tray tttttt. The message may remain for some time after you have closed the tray. You can access help details by pressing the HELP button.
Install Tray tttttt	The printer unit has tried to take paper from a tray that has been removed. Ensure that tray tttttt is correctly located or put tray tttttt loaded with paper back into the printer unit.

<b>Message</b>	<b>Comment</b>
Open Cover Paper Remains tttttt Please see HELP for details	Additional paper has been detected after a paper jam has been cleared. Open tttttt side cover to check for additional paper. You can access help details by pressing the HELP button.
Check Image Drum cccccc Please see HELP for details	Check that the image drum of color cccccc is correctly installed. You can access help details by pressing the HELP button.



# Appendix B – Menu system (Printer unit)

The top-level Functions menus are:

- > Configuration
- > Print Pages
- > Suspend Printing
- > Resume Printing
- > Print Secure Job
- > Menus
- > Shutdown
- > Admin Setup
- > Calibration
- > Print Statistics

The other special top-level menu is:

- > System Maintenance

The following tables summarize the Configuration, Print Pages, Print Secure Job and Menus menu trees and provide some usage examples. The menu trees are given to the lowest menu item level. Typically, this can be a parameter that can be set by selecting from a range of values provided or a command that can be executed to display or print a status or setting value.

Emboldened values followed by an (A) denote default values associated with locations where A4 is default paper size. Emboldened values followed by an (L) denote default values associated with locations where Letter is default paper size. Emboldened values followed by neither (A) nor (L) denote common defaults.

Certain menus and items associated with, for example, the Finisher appear only if the associated hardware is installed or under certain conditions.

The remainder of the menus above are intended for more specialized usage and are not described further here.

## Configuration

### Print Page Count

Item	value	Description
Color Page	nnnnnn	Displays number of color printed pages converted to Letter equivalent.
Monochrome Page	nnnnnn	Displays number of monochrome printed pages converted to Letter equivalent.
Traym	nnnnnn	Displays total printed pages from Traym, where m is in range 1 to 4.
MP Tray	nnnnnn	Displays total printed pages from MP tray.

### Finisher Count

Item	value	Description
Staple	nnnnnn	Displays total pages stapled.
Punch	nnnnnn	Displays total pages punched.
Finisher	nnnnnn	Displays total pages ejected into the Finisher.

### Supplies Life

Item	value	Description
xxxx Drum	Remaining nnn%	Displays the remaining life span of the xxxx drum as a percentage where xxxx can be Cyan, Magenta, Yellow, Black.
Belt	Remaining nnn%	Displays the remaining life span of the belt unit as a percentage.

Item	value	Description
Fuser	Remaining nnn%	Displays the remaining life span of the fuser unit as a percentage.
xxxx Toner (n.nK)	Remaining nnn%	Displays the remaining life span of xxxx toner as a percentage, where xxxx can be Cyan, Magenta, Yellow, Black. (n.nK) indicates the capacity of the toner cartridge being used.

## Network

The items and settings displayed are specific to your system. Full details are given in the Configuration Guide.

## Paper Size in Tray

Item	value	Description
Traym where m is in range 1 to 4 (similar arrangement for all trays)	Executive Letter Short Edge Letter Long Edge Legal 14 Legal 13.5 Tabloid Tabloid Extra Legal 13 A6 A5 A4 Short Edge A4 Long Edge A3 A3 Nobi A3 Wide B5 Short Edge B5 Long Edge B4 Postcard Double Postcard Custom	Displays detected paper size of Traym.
MP Tray	Similar to values for Traym	Displays detected paper size of the MP Tray.

## System

Item	value	Description
Serial Number	xxxxxxxxxxxxxx	Displays serial no. of the printer.
Asset Number	xxxxxxx	Displays Asset Number. Asset Number is 8 alphanumeric characters that can be assigned by a user. Same as Asset Number of Menu Map.
CU Version	xx.xx	Displays version no. of CU (Control Unit) firmware. Same as CU version of Menu Map.
PU Version	xx.xx.xx	Displays version no. of PU (Print Unit) firmware. Same as PU version of Menu Map.

Item	value	Description
Total Memory	xx MB	Displays total RAM memory installed in the printer. Same as Total Memory of Menu Map.
HDD	xx.xx GB [Fxx]	Displays size of hard disk and file system version. Same as HDD of Menu Map.

### Configuration example – monochrome pages printed

To display the total monochrome pages printed so far (remembering that a duplex page counts as two pages):

1. Ensure that the display panel indicates that the printer unit is ready to print.
2. Enter menu mode by pressing either the **Up-arrow** or **Down-arrow** button and press them repeatedly until the Configuration menu is highlighted.
3. Press the **Enter** button to select this menu.
4. Press the **Up-arrow** or **Down-arrow** buttons repeatedly until Print Page Count is highlighted.
5. Press the **Enter** button to select this Item.
6. Press the **Up-arrow** or **Down-arrow** buttons repeatedly until Monochrome Page is highlighted.
7. Press the **Enter** button and the monochrome page count is displayed.
8. Press the **Online** button to exit menu mode and return to the ready to print status.

## Print Pages

Item	Value	Description
PS Test Page	Execute	Prints the PostScript sample page.
Configuration	Execute	Prints printer configuration details.
Job Log	Execute	Prints EFI job log details.
Color Charts (disk only)	Execute	Prints color charts.
PS Font List	Execute	Prints PostScript font list.
PCL Font List	Execute	Prints PCL emulation font list.
Demo Page	Execute	Prints a demo page.
Usage Report	Execute	Prints usage report.
Statistics Log	Execute	Prints Oki job log details.
Error Log	Execute	Prints the error log.
E-mail Log	Execute	Prints e-mail log.
PrintMe Log	Execute	Prints PrintMe Log.

## Print Information example – demonstration page

To print a demo page to demonstrate how your printer unit prints:

1. Ensure that the display panel indicates that the printer unit is ready to print.
2. Enter menu mode by pressing either the **Up-arrow** or **Down-arrow** button and press them repeatedly until the Print Pages menu is highlighted.
3. Press the **Enter** button to select this menu.
4. Press the **Up-arrow** or **Down-arrow** buttons repeatedly until Demo page is highlighted.
5. Press the **Enter** button to select this Item and the demo page is printed.
6. After printing, the printer unit returns to ready to print status.

## Print Secure Job

Item	Value	Description
Enter Password	n n n n	Enter a password to use secure printing.
Not Found		Use a secure printing job (Secure Job) or a job Stored to HDD when printing. When you print a Secure document, it is deleted from the HDD. When you print a document Stored to HDD, it prints and remains stored on the HDD until you manually delete it. <b>Not Found:</b> (no jobs) is indicated when there is no output file. The following messages are displayed when there are printable files. <b>Print:</b> When you select Print, Set Collating Amount is displayed to enable you to specify a number of copies. After specifying the number of copies, press Enter to print all jobs with the specified number of copies. <b>Delete:</b> When you select Delete, you are prompted to recheck by Yes/No display, and selecting Yes deletes all jobs.
Secure Job	Print Delete	

## Menus

### Tray Configuration

Item	Value	Description
Paper Feed	<b>Tray1</b> Tray2 Tray3 Tray4 MP Tray	Specifies a feed tray.
Auto Tray Switch	<b>ON</b> OFF	Sets the automatic tray switch function.
Tray Sequence	<b>Down</b> Up Paper feed tray	Specifies selection order priority for automatic tray selection/automatic tray switch.
Unit of Measure	<b>Inch (L)</b> <b>mm (A)</b>	Specifies units for custom paper size.



Item	Value		Description
Traym Config, where m is in range 1 to 4 (similar arrangement for all trays)	Paper Size	<b>Tray Size</b> Custom	Sets paper in Traym.
	X Dimension	3.9 – <b>8.3</b> (A) – <b>8.5</b> (L) – 12.9 inch 100 – <b>210</b> (A) – <b>216</b> (L) – 328 mm	Sets Custom paper width for Traym. Sets for the direction perpendicular to the direction of paper movement.
	Y Dimension	5.8 – <b>11</b> (L) – <b>11.7</b> (A) – 18 inch 148 – <b>279</b> (L) – <b>297</b> (A) – 457 mm	Sets Custom paper length for Traym. Sets for the same direction as paper movement.
	Media Type	<b>Plain</b> Letterhead Transparency Bond Recycled Card stock Rough Glossy User Type1 User Type2 User Type3 User Type4 User Type5	Sets the media type for Traym. User Type1 to User Type5 are reserved for custom paper sizes set in the printer driver.

Item	Value		Description
Traym Config, where m is in range 1 to 4 (similar arrangement for all trays)	Media Weight	<b>Auto</b> Light Medium Light Medium Medium Heavy Heavy Ultra Heavy 1 Ultra Heavy 2 Ultra Heavy 3	Sets media weight for Traym.
	A3 Nobi Paper	A3 Nobi A3 Wide <b>Tabloid Extra</b>	The printer detects A3 Nobi, A3 Wide and Tabloid Extra sizes as the same. Use this setting to tell the printer which of the three sizes is loaded in Traym.
	Legal 14 Paper	<b>Legal 14</b> Legal 13.5	Sets the length of the legal paper in Traym. Change this to Legal 13.5 if that is the standard legal size in your country.
	A5/A6 Paper	A5/A6 <b>Postcard</b>	The printer detects A5, A6 and Postcard sizes as the same. Use this setting to tell the printer which of the three sizes is loaded in Traym.

Item	Value		Description
MP Tray Config	Paper Size	A3 Nobi A3 Wide A3 A4 Sht Edge <b>A4 Long Edge</b> (A) A5 A6 B4 B5 Short Edge B5 Long Edge Legal 14 Legal 13.5 Tabloid Extra Tabloid Letter Sht Edge <b>Letter Long</b> <b>Edge</b> (L) Executive Custom Com-9 Envelope Com-10 Envelope Monarch Envelope DL Envelope C5 C4 Index Card	Sets paper size for MP Tray.
	X Dimension	3 – <b>8.3</b> (A) – <b>8.5</b> (L) – 12.9 inch 76 – <b>210</b> (A) – <b>216</b> (L) – 328 mm	Sets Custom paper width for the MP Tray. Sets for the direction perpendicular to the direction of paper movement.
	Y Dimension	3.5 – <b>11.0</b> (L) – <b>11.7</b> (A) – 47.2 inch 90 – <b>279</b> (L) – <b>297</b> (A) – 1200 mm	Sets Custom paper length for MP Tray. Sets for the same direction as paper movement.

Item	Value		Description
MP Tray Config	Media Type	<b>Plain</b> Letterhead Transparency Labels Bond Recycled Card stock Rough Glossy Envelope User Type1 User Type2 User Type3 User Type4 User Type5	Sets the media type for MP Tray.
	Media Weight	<b>Auto</b> Light Medium Light Medium Medium Heavy Heavy Ultra Heavy 1 Ultra Heavy 2 Ultra Heavy 3	Sets the media weight for MP Tray.
	Tray Usage	Normal Tray	Tray selection/switching uses this tray as the normal tray.
		<b>When Mismatching</b>	If a paper size or type in a tray is not matched to that of the print data, use paper from this tray instead of the specified tray.
		Do Not Use	Makes the MP tray unavailable in auto tray selection/switching.

## System Adjust

Item	Value	Description
Power Save Time	5 min 15 min 30 min <b>60 min</b> 240 min	Sets the period after which power save mode starts.
Clearable Warning	<b>Online</b> Job	When Online is selected, you must manually clear the warning by pressing the Online button. Change to Job if you wish the message to automatically clear when a new print job is received.
Auto Continue	ON <b>OFF</b>	Sets whether the printer is automatically recovered when Memory Overflow or Tray Request occurs.
Manual Timeout	OFF 30 sec <b>60 sec</b>	If paper is not fed within this time in manual feed, the job is cancelled.
Wait Timeout	OFF 5 sec 10 sec 20 sec 30 sec <b>40 sec</b> 50 sec 60 sec 90 sec 120 sec 150 sec 180 sec 210 sec 240 sec 270 sec 300 sec	Sets the time period between stopping receipt of job data and forced print. For PS, printing is not carried out and the job is cancelled.

Item	Value	Description
Low Toner	<b>Continue</b> Stop	Sets the printing operation when insufficient toner is detected. <b>Continue:</b> the printer can continue printing while remaining online. <b>Stop:</b> the printer stops printing and goes offline.
Jam Recovery	<b>ON</b> OFF	<b>ON:</b> continues printing the job, including any jammed pages, once the jam has been cleared. <b>OFF:</b> Cancels a job including the page currently jammed.
Print Position Adjust	X Adjust	<b>0.00</b> +0.25 – +2.00 -2.00 – -0.25 mm 0.00 +0.01 – +0.08 -0.08 – -0.01 in
	Y Adjust	<b>0.00</b> +0.25 – +2.00 -2.00 – -0.25 mm 0.00 +0.01 – +0.08 -0.08 – -0.01 in

Item	Value		Description
Print Position Adjust	Duplex X Adjust	<b>0.00</b> +0.25 – +2.00 -2.00 – -0.25 mm 0.00 +0.01 – +0.08 -0.08 – -0.01in	During the flip-side printing of duplex printing, adjusts the location of the whole printing image (0.25 mm, 0.01in interval) perpendicular to the direction of paper movement (i.e. horizontally).
	Duplex Y Adjust	<b>0.00</b> +0.25 – +2.00 -2.00 – -0.25 mm 0.00 +0.01 – +0.08 -0.08 – -0.01 in	During the flip-side printing of duplex printing, adjusts the location of the whole printing image (0.25 mm, 0.01 in interval) parallel to the direction of paper movement (i.e. vertically).
xxxx Darkness	<b>0</b> +1 – +3 -4 – -1		Adjusts the xxxx engine density where xxxx is one of Cyan, Magenta, Yellow, Black. Darkest value is +3.
xxxx Reg Fine Adjust	<b>0</b> +1 – +3 -3 – -1		Makes fine adjustment to image registration in xxxx against Black in the horizontal direction, where xxxx is one of Cyan, Magenta, Yellow. If the paper movement direction is upward, a value set on the plus side, means the image relatively moves downward.

Item	Value		Description
Paper Black Setting	<b>0</b> +1 - +2 -2 - -1		Used for micro adjustment when very visible faded print results or light specks (or streaks) result when printing in Plain Paper/Black setting. Decrease the value if light specks (or streaks) or snow flake like printing results in high density print areas.
Paper Color Setting	<b>0</b> +1 - +2 -2 - -1		Used for micro adjustment when very visible faded print results or light specks (or streaks) result when printing in Plain Paper/Color setting. Decrease the value if light specks (or streaks) or snow flake like printing results in high density print areas.
Transparency Black Setting	<b>0</b> +1 - +2 -2 - -1		As for Paper Black Setting above.
Transparency Color Setting	<b>0</b> +1 - +2 -2 - -1		As for Paper Color Setting above.
Drum Cleaning	<b>ON</b> <b>OFF</b>		Set to produce idling of a drum before printing in order to reduce horizontal white lines. This shortens image drum life.
Hex Dump	Execute		Prints out the data received from the host PC in hexadecimal code.

## Menus example 1 – Tray 1 transparencies

To print on transparencies (accommodated in Tray1):



1. Ensure that the display panel indicates that the printer unit is ready to print.
2. Enter menu mode by pressing either the **Up-arrow** or **Down-arrow** button and press them repeatedly until the Menus menu is highlighted.
3. Press the **Enter** button to select this menu.
4. Press the **Up-arrow** or **Down-arrow** buttons repeatedly until Tray Configuration is highlighted.
5. Press the **Enter** button to select this Item.
6. Press the **Up-arrow** or **Down-arrow** buttons repeatedly until Tray1 Config is highlighted.
7. Press the **Enter** button to select this Item.
8. Press the **Up-arrow** or **Down-arrow** buttons repeatedly until MediaType is highlighted.
9. Press the **Enter** button to select this Item.
10. Press the **Up-arrow** or **Down-arrow** buttons repeatedly to move through the range of media types until Transparency is highlighted.
11. Press the **Enter** button to select this value.
12. Check that an asterisk (\*) appears beside Transparency.
13. Press the **Online** button to exit menu mode and return to the ready to print status.

## Menus example 2 – MP Tray paper size

To set paper size in the MP Tray:

1. Ensure that the display panel indicates that the printer unit is ready to print.
2. Enter menu mode by pressing either the **Up-arrow** or **Down-arrow** button and press them repeatedly until the Menu menu is highlighted.
3. Press the **Enter** button to select this menu.
4. Press the **Up-arrow** or **Down-arrow** buttons repeatedly until Tray Configuration is highlighted.
5. Press the **Enter** button to select this Item.
6. Press the **Up-arrow** or **Down-arrow** buttons repeatedly until MP Tray Config is highlighted.
7. Press the **Enter** button to select this Item.
8. Press the **Up-arrow** or **Down-arrow** buttons repeatedly until Paper Size is highlighted.
9. Press the **Enter** button to select this Item.
10. Press the **Up-arrow** or **Down-arrow** buttons repeatedly to move through the range of paper sizes until the required size is highlighted.
11. Press the **Enter** button to select this value.
12. Check that an asterisk (\*) appears beside the chosen size.
13. Press the **Online** button to exit menu mode and return to the ready to print status.

## Appendix C – Scanner Unit Status

The scanner unit display panel is intended to be self explanatory and provides textual status information and help information (if appropriate) for both the scanner unit and the printer unit. A scanner image is also provided to help indicate where a scanner unit problem has occurred. In the case of a printer unit problem, you are redirected to the printer unit control panel for more detailed information and help.

As an example, the following screen shows that an original document has jammed in the ADF (1) and there is also a printer unit error which requires you to refer to the printer unit control panel for further information (2).

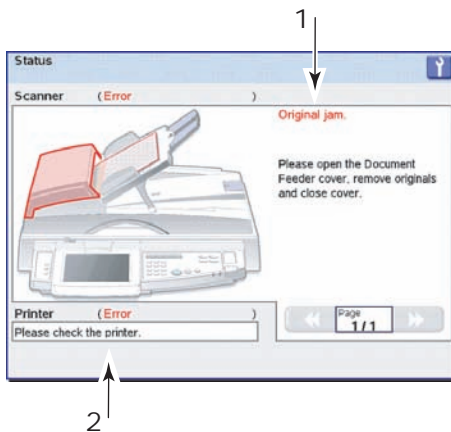

# Appendix D – Media support information

The following tables should be read together and define media sizes in allowable input and output combinations, including Finisher unit punching and stapling options.

Explanations of terms used in the table headings are:

> **B: 2-sided printing (Booklet)**

> **N: N-up printing**

> **F: Fit to page**

> **Paper input locations:**

A: Auto

T1 to T4: Trays 1 to 4

MPT: Multi-purpose Tray

> **Paper output locations:**

FUS: Face up stacker

FDS: Face down stacker

FFUS: Finisher face up stacker

FFDS: Finisher face down stacker

> **Punching options:**

2HT: 2 Hole top

4HT: 4 Hole top

2HLR: 2 Hole left or right

4HLR: 4 Hole left or right

> **Stapling options:**

TL: Top left position

TR: Top right position

T2: Top 2 position

L2: Left 2 position

R2: Right 2 position

SS: Saddle stitch

Symbols used in the table bodies are:

> **Y: Supported i.e. allowable by the MFP**

Y1: Media ejection possible, but no print guarantee

Y2: Short Edge Feed (SEF) only

Y3: Media output route is limited by size and an error message may result

Y4: Feed direction is determined by the print orientation (Portrait/Landscape) and the N-up setting

Y5: Long Edge Feed (LEF) only

> **N: Not supported i.e. not allowable by the MFP**

## Input locations

Media size	B	N	F	A	T1	T2	T3	T4	M
A3	Y	Y	Y	Y	Y	Y	Y	Y	Y
A4	Y	Y	Y	Y	Y	Y	Y	Y	Y
A5	Y	Y	Y	Y	Y	Y	Y	Y	Y
A6	Y	Y	Y	Y	Y	Y	Y	Y	Y
B4	Y	Y	Y	Y	Y	Y	Y	Y	Y
B5	Y	Y	Y	Y	Y	Y	Y	Y	Y
Letter	Y	Y	Y	Y	Y	Y	Y	Y	Y
Legal 14in	Y	Y	Y	Y	Y	Y	Y	Y	Y
Legal 13.5in	Y	Y	Y	Y	Y	Y	Y	Y	Y
Legal 13in	Y	Y	Y	Y	Y	Y	Y	Y	Y
Executive	Y	Y	Y	Y	Y	Y	Y	Y	Y
Tabloid	Y	Y	Y	Y	Y	Y	Y	Y	Y
Tabloid Extra	Y	Y	Y	Y	Y	Y	Y	Y	Y
A3 Nobis	Y	Y	Y	Y	Y	Y	Y	Y	Y
A3 Wide	Y	Y	Y	Y	Y	Y	Y	Y	Y
Index card	N	Y	Y	Y	N	N	N	N	Y
DL	N	Y	Y	Y	N	N	N	N	Y
C4	N	Y	Y	Y	N	N	N	N	Y
C5	N	Y	Y	Y	N	N	N	N	Y
Com-10	N	Y	Y	Y	N	N	N	N	Y
Com-9	N	Y	Y	Y	N	N	N	N	Y
Monarch	N	Y	Y	Y	N	N	N	N	Y
Custom	Y	Y	Y	Y	Y	Y	Y	Y	Y
A4LEF	Y	Y	Y	Y	Y	Y	Y	Y	Y
A4SEF	Y	Y	Y	Y	Y	Y	Y	Y	Y
B5LEF	Y	Y	Y	Y	Y	Y	Y	Y	Y

<b>Media size</b>	<b>B</b>	<b>N</b>	<b>F</b>	<b>A</b>	<b>T1</b>	<b>T2</b>	<b>T3</b>	<b>T4</b>	<b>M</b>
B5SEF	Y	Y	Y	Y	Y	Y	Y	Y	Y
Letter LEF	Y	Y	Y	Y	Y	Y	Y	Y	Y
Letter SEF	Y	Y	Y	Y	Y	Y	Y	Y	Y

## Printer unit output locations

Media size	FUS	FDS
A3	Y	Y
A4	Y	Y
A5	Y	Y
A6	Y	Y
B4	Y	Y
B5	Y	Y
Letter	Y	Y
Legal 14in	Y	Y
Legal 13.5in	Y	Y
Legal 13in	Y	Y
Executive	Y	Y
Tabloid	Y	Y
Tabloid Extra	Y	Y
A3 Nobi	Y	Y
A3 Wide	Y	Y
Index card	Y	N
DL	Y	N
C4	Y	N
C5	Y	N
Com-10	Y	N
Com-9	Y	N
Monarch	Y	N
Custom	Y	Y3
A4LEF	Y	Y
A4SEF	Y	Y
B5LEF	Y	Y



<b>Media size</b>	<b>FUS</b>	<b>FDS</b>
B5SEF	Y	Y
Letter LEF	Y	Y
Letter SEF	Y	Y

## Finisher unit output locations

Media size	Ff U S	FF D S	2 H T	4 H T	2 H L R	4 H L R	T L	T R	T 2	L 2	R 2	S S
A3	Y	Y	Y	Y	Y	Y	Y	Y	Y	Y	Y	Y
A4	Y	Y	Y4	Y5	Y4	Y5	Y4	Y4	Y4	Y4	Y4	Y2
A5	Y	Y	N	N	N	N	N	N	N	N	N	N
A6	Y1	Y1	N	N	N	N	N	N	N	N	N	N
B4	Y	Y	Y	N	Y	N	Y	Y	Y	Y	Y	Y
B5	Y	Y	Y4	N	Y4	N	Y5	Y5	Y5	Y5	Y5	N
Letter	Y	Y	Y4	N	Y4	N	Y4	Y4	Y4	Y4	Y4	Y2
Legal 14	Y	Y	Y	N	Y	N	Y	Y	Y	Y	Y	N
Legal 13.5	Y	Y	Y	N	Y	N	Y	Y	Y	Y	Y	N
Legal 13	Y	Y	Y	N	Y	N	Y	Y	Y	Y	Y	N
Executive	Y	Y	Y	N	Y	N	Y	Y	Y	Y	Y	N
Tabloid	Y	Y	Y	N	Y	N	Y	Y	Y	Y	Y	N
Tabloid Extra	N	N	N	N	N	N	N	N	N	N	N	N
A3 Nobi	N	N	N	N	N	N	N	N	N	N	N	N
A3 Wide	N	N	N	N	N	N	N	N	N	N	N	N
Index card	N	N	N	N	N	N	N	N	N	N	N	N
DL	N	N	N	N	N	N	N	N	N	N	N	N
C4	N	N	N	N	N	N	N	N	N	N	N	N
C5	Y1	N	N	N	N	N	N	N	N	N	N	N
Com-10	N	N	N	N	N	N	N	N	N	N	N	N
Com-9	N	N	N	N	N	N	N	N	N	N	N	N
Monarch	N	N	N	N	N	N	N	N	N	N	N	N
Custom	Y3	Y3	N	N	N	N	N	N	N	N	N	N

<b>Media size</b>	<b>Ff U S</b>	<b>FF D S</b>	<b>2 H T</b>	<b>4 H T</b>	<b>2 H L R</b>	<b>4 H L R</b>	<b>T L</b>	<b>T R</b>	<b>T 2</b>	<b>L 2</b>	<b>R 2</b>	<b>S S</b>
A4LEF	Y	Y	Y4	Y	Y4	Y	Y4	Y4	Y4	Y4	Y4	N
A4SEF	Y	Y	Y4	N	Y4	N	Y4	Y4	Y4	Y4	Y4	Y
B5LEF	Y	Y	Y4	N	Y4	N	Y	Y	Y	Y	Y	N
B5SEF	Y	Y	Y4	N	Y4	N	N	N	N	N	N	N
Letter LEF	Y	Y	Y4	N	Y4	N	Y4	Y4	Y4	Y4	Y4	N
Letter SEF	Y	Y	Y4	N	Y4	N	Y4	Y4	Y4	Y4	Y4	Y

# Appendix E – Auto detection paper sizes

The following tables define which document sizes can be scanned (flatbed or ADF) when using the Auto setting.

*NOTE*

*(a) settings are mutually exclusive with (b) settings and cannot be changed by the user.*

*Changing between a (c) or (d) setting can be carried out by the user.*

## Flatbed (document glass)

Paper type	Paper size (mm)	Paper size (inch)
A3	290 x 420	11.69 x 16.54
A4 (SEF)	210 x 297	8.27 x 11.69
A4 (LEF)	297 x 210	11.69 x 8.27
A5 (SEF) (a)	148 x 210	5.83 x 8.27
A5 (LEF) (a)	210 x 148	8.27 x 5.83
B4	257 x 364	10.12 x 14.33
B5 (SEF)	182 x 257	7.17 x 10.12
B5 (LEF)	257 x 182	10.12 x 7.17
(b)	140 x 216	5.5 x 8.5
(b)	216 x 140	8.5 x 5.5
Letter (SEF)	216 x 279	8.5 x 11
Letter (LEF)	279 x 216	11 x 8.5
Legal13 (c)	216 x 330	8.5 x 13
Legal14 (d)	216 x 356	8.5 x 14
Tabloid	279 x 432	11 x 17

## ADF

<b>Paper type</b>	<b>Paper size (mm)</b>	<b>Paper size (inch)</b>
A3	297 x 420	11.69 x 16.54
A4 (SEF) (a)	210 x 297	8.27 x 11.69
A4 (LEF)	297 x 210	11.69 x 8.27
A5 (SEF) (a)	148 x 210	5.83 x 8.27
B4 (SEF)	257 x 364	10.12 x 14.33
B5 (SEF)	182 x 257	7.17 x 10.12
B5 (LEF)	257 x 182	10.12 x 7.17
(b)	140 x 216	5.5 x 8.5
Letter (SEF) (b)	216 x 279	8.5 x 11
Letter (LEF)	279 x 216	11 x 8.5
Legal13 (c)	216 x 330	8.5 x 13
Legal14 (d)	216 x 356	8.5 x 14
Tabloid	279 x 432	11 x 17

# Appendix F – Scanner unit setup details

This section provides an overview of the setup facilities on your scanner unit.

Press the **SETUP** button on the scanner unit control panel to show the Setup Mode screen with the Setup Main Menu:

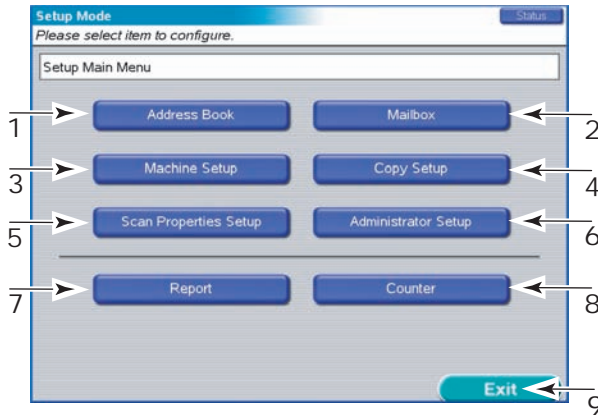

## Setting up address books

Press the Address Book button (1) to gain access to the following:

- > E-Mail Address Book  
Add/Edit/Delete/Search e-mail addresses (up to 500 entries).
- > Import from LDAP Server  
Search for e-mail addresses from LDAP server and import the result into the local address book (up to 500 entries).
- > FTP Server List  
Add/Edit/Delete local FTP server list.  
Set a range of parameters e.g. User ID, Password, Path, for each entry.

Press the OK button to return to the Setup Main Menu.

## Setting up mailboxes

Press the Mailbox button (2) to gain access to the following:

- > Mailbox List

Add/Edit/Delete mailbox entries.

Assign a password to each mailbox.

If a mailbox password has been lost, the mailbox can be deleted by using the Administrator password.

Press the OK button to return to the Setup Main Menu.

## Setting up machine parameters

Press the Machine Setup button (3) to gain access to the following:

- > Power Save Delay Time

Set the time after which power save mode will operate: 5, 15, 30, 60, 240min.

- > Sound Control

- > Key Touch Tone Volume: Set to OFF, Low, High.

- > Buzzer Volume: Set to OFF, Low, High.

Press the Save/Return button to return to the Setup Main Menu.

## Setting up copying parameters

Press the Copy Setup button (4) to gain access to the following:

- > Original Settings

Define default paper size and data type (Mixed, Text or Photo) of original data for the COPY function.

- > Color & Quality

Define default setting for Resolution, Color Mode, Color Presets, Exposure Settings (Lighter/Darker and Contrast), Color Saturation, Sharpness, and Background Removal.

- > Reduce/Enlarge

Define default Reduce/Enlarge Settings.

- > **Layout**  
Define default setting of Image Sides, Book Copy, Margin Shift, and N-up.
- > **Image processing**  
Define default setting of Edge/Center Erase.
- > **Print/Finishing Settings**  
Define default setting of Tray Selection, Face up/down Print Output, Output Order/Collate, Staple Position, and Punch Position.

Press the Save/Return button to return to the Setup Main Menu.

## **Setting up scan properties**

Press the Scan Properties Setup button (5) to gain access to the following:

- > **Original Settings**  
Original Size: Define default paper size of original data for SCAN TO EMail/SCAN TO FTP/SCAN TO MAILBOX/SCAN TO HOLD QUEUE functionality.
- > **Color & Quality**  
Define default setting for Resolution, Color Mode, and Exposure Settings (Lighter/Darker and Contrast).
- > **Image processing**  
Define default setting for Edge/Center Erase Unit.
- > **Image/Compression**  
Define default setting for File Format and Compression Level.

Press the Save/Return button to return to the Setup Main Menu.



## Administrator setup

### NOTE

*The Administrator password is required.*

Press the Administrator Setup button (6) to gain access to the following:

- > Power Save Mode  
Enable/disable power save mode.
- > Password for Administrator  
Set MFP administrator password. The default is "".
- > Access Control  
Enable/disable PIN (Personal Identification Number) authentication. If the PIN authentication is enabled, each user is authenticated by the last 4 digits of ID for Job Accounting. The PIN is provided by the Job Accounting Utility.
- > Scan to E-Mail  
Enable/disable SCAN TO E-MAIL.
- > Scan to FTP  
Enable/disable SCAN TO FTP.
- > Proxy Settings
  - > Server Name: Set FTP proxy server name or IP address.
  - > User Name: Set user name for the proxy server.
  - > Port Number: Set port number of the proxy server.
- > LDAP Settings
  - > Server Name: Set LDAP server name or IP address.
  - > Port Number: Set the port number of LDAP.
  - > Timeout: Set the time out in seconds (10 – 120sec) for the search.
  - > Max. Entries: Set the maximum number of E-Mail addresses that the MFP unit can receive in each search. The Clear button resets this value to the default.

- > Search Root: Set the root DN (Distinguished Name).
- > Attributes: Specify LDAP attribute corresponding to "Name", "Surname", "First Name", and "Mail Address". The specified attributes are used to query. The default attributes are:
  - "cn" for "Name"
  - "sn" for "Surname"
  - "givenname" for "First Name"
  - "mail" for "Mail Address"
- > Additional Filter: Specify the additional filter e.g. "(c=JP)".
- > Authentication: Specify the authentication method for LDAP access.
  - "Anonymous": No authentication
  - "Simple": ID & password authentication. They are sent in plain format. "User ID" and "Password" can be set here in advance, or left blank. If they are not set here, user should set them when E-Mail address search by LDAP is carried out.
  - "Secure Protocol": Authentication method for MS Active Directory. "User ID", "Password" and "Domain" can be set here in advance, or left blank. If they are not set here, user should set them when E-Mail address search by LDAP is carried out.
- > Scanned File Settings
  - > Max. File Size (E-Mail): Specify the maximum image size (0 – 15,000KB) to be sent as an attachment. Clear button resets this value to the default.
  - > Clear File After Scan: Specify the duration before deleting files from Mailboxes or the images referred to via URLs in sent E-Mails. If Manual is selected, the image should be deleted by Delete All Scan Job.
  - > Delete All Scan Job: Delete data from Mailboxes or the images referred to via URLs in sent E-Mails manually.
- > Timer
  - > Copy Reset Timer: Specify the duration(10 – 600 sec in 10 sec intervals) from COPY operation completion until the MFP resets all related settings to their default values.

- > Operation Timer: Specify the duration (10 – 600 sec in 10 sec intervals) from user operation completion until the MFP displays the waiting screen.
- > Job Reset Timer: Specify the duration (10 – 600 sec in 10 sec intervals) from pausing the COPY/SCAN TO process until the MFP cancels the job.
- > Security
  - > Address Book security: If ON is selected and the administrator password is set, the password authentication is carried out before all operations for E-Mail address book/FTP server list and E-Mail address importing operation by LDAP. If OFF is selected, the password authentication is not carried out.
  - > LDAP security: If ON is selected and the administrator password is set, the password authentication is carried out before all operations to access LDAP server. If OFF is selected, the password authentication is not carried out.
  - > Legal Default: Specify the paper size (Legal13 or Legal14) that the MFP uses if it detects a Legal size document when Original Size is set to "Auto".
- > Dealer's Information
  - > Telephone Number, Fax Number, E-Mail Address: Set dealer's information.
  - > Fax Gateway Mail Address: Set the mail address of the Fax Gateway. If it is not set, the "Fax Gateway" function cannot be used.

Press the Save/Return button to return to the Setup Main Menu.

## Generating reports

Press the Report button (7) to gain access to printing the following:

- > Administrator Setup Report (The Administrator password is required.)
- > User Setup Report
- > Job Log Report

- > E-Mail Report
- > FTP Report
- > MFP Statistics Report

Press the OK button to return to the Setup Main Menu.

## Scanner unit counter readings

### *NOTE*

*The Administrator password is required.*

Press the Counter button (8) to display counter values.

- > PAD counter  
Total number of pages handled by the document feeder.
- > Document Feeder (Simplex)  
The number of pages scanned as single-sided.
- > Document Feeder (Duplex)  
The number of pages scanned as double-sided.
- > Flatbed (glass)  
The number of pages scanned on the glass.

### *NOTE*

*Counters return to 0 after 999,999.*

*User cannot clear the counters.*

Press the OK button to return to the Setup Main Menu.

## Setup complete

When you have finished setting up, press the Exit button (9).

# Appendix G– Troubleshooting (network)

Possible network problems with suggested checks are provided below. Further network troubleshooting information is provided in the Fiery Configuration Guide.

## Cannot send e-mail

If you are unable to send e-mail, check that the following are configured correctly.

	category	Item	Comment
Printer unit	Admin Setup> Network Setup> Service Setup> E-mail Setup	Enable E-mail Services	Must be Yes.
		Outgoing server	Must be specified.
		Fiery E-mail Address	Must be specified.
		Admin. E-mail Address	Must be specified.
Scanner unit	Administrator Setup	Scan to E-Mail	Must be Enable.

## Cannot search on LDAP server

If you cannot connect to or search on LDAP server, check that the following are configured correctly.

	category	Item	Comment
Scanner unit	Administrator Setup> LDAP Settings	Server Name	These are site-specific settings and must be specified correctly. Contact the LDAP server administrator if you need help.
		Port Number	
		Search Root	
		Authentication	

In addition, if you select Secure Protocol as the Authentication Method to access the MS Active Directory, check that the following are configured correctly.

	<b>category</b>	<b>Item</b>	<b>Comment</b>
Printer unit	Admin Setup> Network Setup> TCP/IP Setup	DNS Setup	Must be specified correctly, to access DNS server.
	Admin Setup> Server Setup	System Date	Must be adjusted to LDAP server's date.
		System Time	Must be adjusted to LDAP server's time.
		Time Zone	Must be adjusted to LDAP server's time zone.
Scanner unit	Administrator Setup> LDAP Settings> Authentication	Domain	Domain must be registered in DNS server.

## Appendix H – Touch screen setup

This section provides an overview of the control functions available for the touch screen display on the scanner unit.

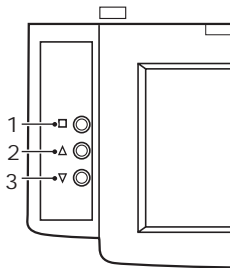

On the scanner unit control panel, press the Menu button (1) to display the OSD then press the Up-arrow (2) or Down-arrow (3) buttons to reach the required function. Press the Menu button, use the Up-arrow and Down-arrow buttons to locate the required option then press the Menu button to set the option and return to the OSD main menu.

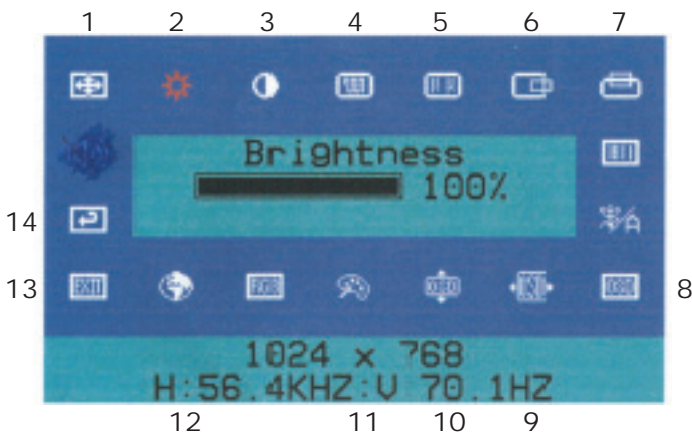

No.	Function	Description
1	Auto Adjust	Automatically adjusts Horizontal Position, Vertical Position, Pixel Clock and Phase for an optimal image. Press the Menu button to execute.
2	Brightness	Adjusts the brightness of the screen.
3	Contrast	Adjusts the difference between the light and dark areas.
4	Clock	Adjusts the video distortion. (Horizontal noise appears on the screen while adjusting the Clock.)
5	Phase	Adjusts the video distortion. (Vertical noise appears on the screen while adjusting the Phase.)
6	Horizontal Position	Moves the display image horizontally. Up-arrow button moves image to right, Down-arrow button moves image to left.
7	Vertical Position	Moves the display image vertically. Up-arrow button moves image upwards, Down-arrow button moves image downwards.
8	OSD Transparency	Adjusts the OSD transparency.
9	OSD H-Position	Adjusts the OSD horizontal position. Up-arrow button moves OSD to right, Down-arrow button moves OSD to left.
10	OSD V-Position	Adjusts the OSD vertical position. Up-arrow button moves OSD upwards, Down-arrow button moves OSD downwards.
11	Switch Color	Adjusts the color temperature.
12	OSD Language	Changes the OSD language.
13	Exit	Exits the OSD menu and saves the values. Press the Menu button to execute.
14	Memory Recall	Restores all settings to factory default values. Press the Menu button to execute.



# Index

## A

- accessories 121
  - installing 121
  - order details 121
- arrow buttons 40

## B

- back button 41

## C

- cancel button 41
- cleaning
  - feed rollers 106
  - LED heads 102
  - printer casing 110
- clearing
  - paper jams 122
  - staple jams 160
- consumables
  - order details 101
  - replacing 100
- control panel
  - adjusting 39
  - controls 40

## D

- display 40
  - Configuration information 42
  - Help information 43
  - Menu information 42
  - messages 167
  - Status information 41

## E

- enter button 41

## F

- features
  - optional 9

## H

- help button 41

## I

- indicator light
  - attention 40
  - ready 40
- interface
  - Ethernet 51, 52
  - parallel 50, 51
  - USB 50, 52

## M

- maintenance items
  - order details 101
  - replacing 100
- menu
  - Admin Setup 169
  - Calibration 169
  - Configuration 169, 170
  - Menus 169, 176
  - Print Information 174
  - Print Pages 169
  - Print Secure Job 169, 176
  - Print Statistics 169
  - Resume Printing 169
  - Shutdown 169
  - Suspend Printing 169
  - System Maintenance 169
  - using 43

## O

- online button 41

## P

- paper
  - duplex printing 28
  - face-down stacker 28
  - face-up stacker 28
  - inputs 26
  - loading 29
  - MP tray 27
  - outputs 26
  - stackers 34
  - trays 27
- paper jams
  - ADF 159
  - avoiding 156
  - duplex 135
  - finisher 140
  - inverter 150
  - side cover 123
  - top cover 127
- printer unit
  - components 17
  - specifications 165
- printing 55
- punch chip box
  - emptying 111

## **R**

recommended media 25  
remote scan 87

## **S**

scan to e-mail 69  
scan to FTP 79  
scan to hold queue 96  
scan to mailbox 88  
scanner unit  
    copy settings 61  
    help 59  
    log in 56  
    log out 57  
    scanning 69  
    status 58  
shutdown/restart button 40  
software 25  
specifications 165

## **T**

troubleshooting 122  
turning  
    off 47  
    on 49

## **U**

unsatisfactory printing 157  
user's guide  
    printing 12