

ML1120/ML1190

**OKI**

MICROLINE 1120

SEL ALARM

SEL

FONT

LF/FF

PITCH

LOAD/EJECT

## User's Guide

ML1120/ML1190



# PREFACE

Every effort has been made to ensure that the information in this document is complete, accurate, and up-to-date. Oki Printing Solutions assumes no responsibility for the results of errors beyond its control. Oki Printing Solutions also cannot guarantee that changes in software and equipment made by other manufacturers and referred to in this guide will not affect the applicability of the information in it. Mention of software products manufactured by other companies does not necessarily constitute endorsement by Oki Printing Solutions.

While all reasonable efforts have been made to make this document as accurate and helpful as possible, we make no warranty of any kind, expressed or implied, as to the accuracy or completeness of the information contained herein.

The most up-to-date drivers and manuals are available from the Oki Printing Solutions web site:

**<http://www.okiprintingsolutions.com>**

Copyright © 2010 Oki Printing Solutions.

Oki, OKI Printing Solutions and Microline are registered trademarks of Oki Electric Industry Co., Ltd.

Microsoft, MS-DOS and Windows are registered trademarks of Microsoft Corporation.

Other product names and brand names are registered trademarks or trademarks of their proprietors.



This product complies with the requirements of the Council Directives 2004/108/EC (EMC), 2006/95/EC (LVD) and 2011/65/EU (ROHS) as amended where applicable on the approximation of the laws of the member states relating to electromagnetic compatibility, low voltage and restriction of hazardous substances.



# CONTENTS

<b>Introduction</b> .....	<b>6</b>
About this guide .....	6
On-line usage .....	7
Printing pages .....	7
<b>Getting started</b> .....	<b>9</b>
Retaining packing materials .....	9
Identifying component parts .....	9
Front view .....	9
Rear view .....	11
Locating your printer .....	12
Powering on your printer .....	12
Producing a test print .....	13
<b>Connecting to a computer</b> .....	<b>15</b>
Interfaces .....	15
Interconnection .....	15
Installing the printer driver .....	16
Printing a test page .....	16
<b>Printing from a computer</b> .....	<b>17</b>
<b>Utilities</b> .....	<b>18</b>
Overview .....	18
Accessing .....	18
Description of utilities .....	18
Installing the utilities .....	19
Windows .....	19
OKI DIPUS (Dot Impact Printer Utilities) .....	19
General information .....	19
How to install .....	19
Additional information .....	19
Status Monitor .....	19
Menu Setup Utility .....	20
Top of Form Setup Utility .....	20
Switch Setup Utility .....	20
<b>Paper handling</b> .....	<b>21</b>
Loading cut sheet paper .....	21
Ejecting cut sheet paper .....	24
Loading continuous forms .....	25
Setting up continuous forms .....	25
Feeding continuous forms .....	25
Tearing off continuous forms .....	31
Aligning the tear-off perforations .....	31

Removing continuous forms . . . . .	32
How to use Bottom Tractor . . . . .	34
Setting the Paper Thickness lever. . . . .	41
<b>Operating instructions . . . . .</b>	<b>42</b>
Control panel . . . . .	42
ML1120 . . . . .	42
ML1190 . . . . .	44
Buttons. . . . .	46
Setting menu values . . . . .	47
Confirming current settings . . . . .	47
Menu setting. . . . .	48
ML1120 . . . . .	49
ML1190 . . . . .	57
Initialising menu settings . . . . .	64
Adjusting TOF position . . . . .	64
Printer speed settings . . . . .	66
Printer impact mode. . . . .	66
Normal speed printing . . . . .	66
High speed printing . . . . .	66
Quiet printing . . . . .	66
Setting TOF position at the place of user's choice . . . . .	67
<b>Troubleshooting . . . . .</b>	<b>68</b>
Clearing paper jams. . . . .	68
Cut sheet paper jammed in printer. . . . .	68
Continuous forms jammed in printer . . . . .	70
Responding to alarm conditions . . . . .	72
Responding to general problems. . . . .	72
<b>Cleaning your printer. . . . .</b>	<b>77</b>
Printer exterior . . . . .	77
Printer interior . . . . .	77
<b>Consumables and accessories . . . . .</b>	<b>79</b>
Consumables. . . . .	79
Changing a ribbon cartridge . . . . .	79
Consumable order information . . . . .	82
<b>Specifications. . . . .</b>	<b>83</b>
ML1120. . . . .	83
ML1190. . . . .	85
<b>Index . . . . .</b>	<b>87</b>
<b>Oki contact details. . . . .</b>	<b>88</b>

## NOTES, CAUTIONS AND WARNINGS.

---

### *NOTE*

*A note provides additional information to supplement the main text.*

---

### **CAUTION!**

**A caution provides additional information which, if ignored, may result in equipment malfunction or damage.**

### **WARNING!**

**A warning provides additional information which, if ignored, may result in a risk of personal injury.**

# INTRODUCTION

Congratulations on purchasing this Oki Printing Solutions printer!

The ML1120 (9-pin) and ML1190 (24-pin) are designed to provide highly reliable letter quality printing and high resolution graphics for the desktop/office printing environment. Both models combine state-of-the-art serial impact dot matrix printing technology with advanced materials and superior construction to provide high performance and versatility in a desktop sized unit. Careful attention to ergonomics and application needs provides user friendly operation for operators of varying technical capabilities.

## ABOUT THIS GUIDE

---

### *NOTE*

*Images used in this manual may include optional features that your printer does not have installed.*

---

This manual is your user's guide (check the web site, [www.okiprintingsolutions.com](http://www.okiprintingsolutions.com), for the most up-to-date version) for your printer and forms part of the overall user support listed below:

- > **This User's Guide:** to help you to become familiar with your printer and make the best use of its many features. Also included are guidelines for troubleshooting and maintenance to ensure that it performs at its best. Additionally, information is provided for adding optional accessories as your printing needs evolve.

This is an electronic document stored on the manuals CD.

- > **Technical Reference Guide:** to provide detailed technical information for programmers and more technical users.

This is an electronic document available on the web site [www.okiprintingsolutions.com](http://www.okiprintingsolutions.com).

- > **Installation Guides:** accompany consumable items and optional accessories to describe how to install them.

These are paper documents that are packaged with the consumables and optional accessories.

- > **On-line Help:** on-line information accessible from the printer driver and utility software.

## ON-LINE USAGE

This guide is intended to be read on screen using an Adobe Acrobat Reader. Use the navigation and viewing tools provided in Acrobat.

You can access specific information in two ways:

- > In the list of bookmarks down the left hand side of your screen, click on the topic of interest to jump to the required topic. (If the bookmarks are not available, use the "[Contents](#)" on page 3.)
- > In the list of bookmarks, click on Index to jump to the Index. (If the bookmarks are not available, use the "[Contents](#)" on page 3.) Find the term of interest in the alphabetically arranged index and click on the associated page number to jump to the page containing the term.

## PRINTING PAGES

The whole manual, individual pages, or sections may be printed. The procedure is:

1. From the toolbar, select File > Print (or press the Ctrl + P keys).

2. Choose which pages you wish to print:
  - (a) [All pages], (1), for the entire manual.
  - (b) [Current page], (2), for the page at which you are looking.

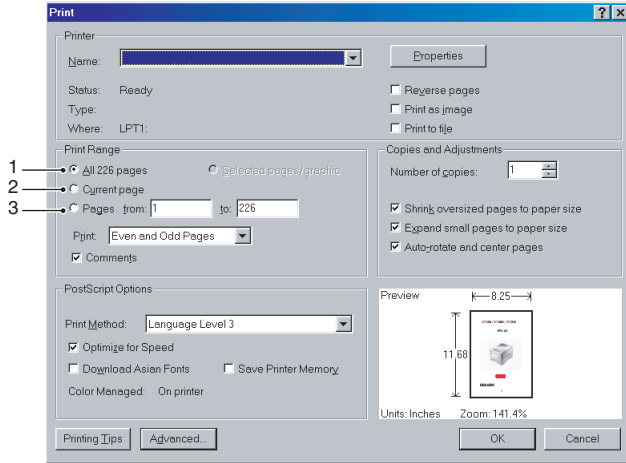

- (c) [Pages from] and [to], (3), for the range of pages you specify by entering their page numbers.
3. Click on OK.



## GETTING STARTED

### WARNING!

If you have not already done so, familiarise yourself with the content of the Installation Safety booklet supplied with your printer.

### RETAINING PACKING MATERIALS

After setting up your printer according to the instructions in the Set-up Guide, retain your packing materials and container in case you ever need to ship or transport your printer.

### IDENTIFYING COMPONENT PARTS

The main parts of your printer are identified and briefly explained below.

#### FRONT VIEW

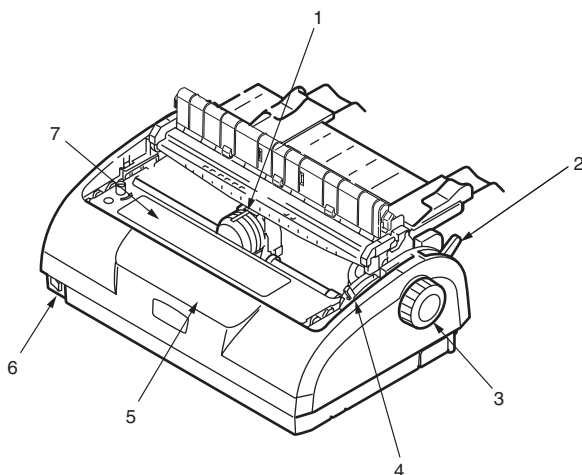

1. Print Head: prints the characters on the paper.
2. Paper Type Lever: set according to the type of paper used - cut sheet or continuous forms.

3. Platen Knob: turn to move or eject the paper.
4. Paper Thickness Lever: set according to the thickness of the paper. There is also a setting to facilitate ribbon replacement.
5. Control Panel: contains button switches and indicators (described in detail later) that allow you to operate the printer.

ML1120

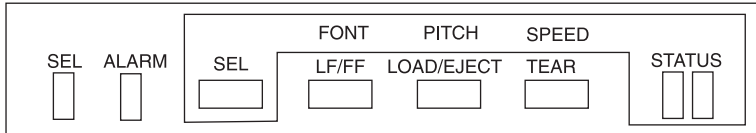

ML1190

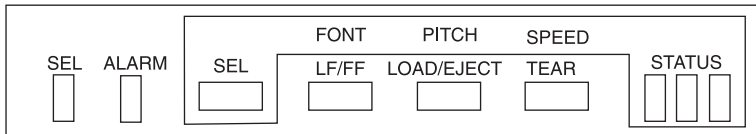

6. Power Switch: to turn the printer power ON/OFF.
7. Ribbon Cartridge: holds the printer ribbon.

## REAR VIEW

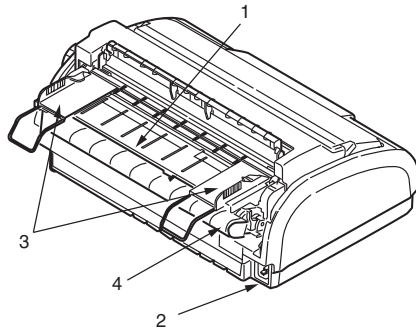

1. Paper Tray: insert cut sheet paper for use by the printer (one sheet at a time)
2. Power connector: connect to printer power cable.
3. Paper Guides: can be adjusted as required to locate the left edge of cut sheet paper.
4. Pin Tractor: to load and feed continuous forms.

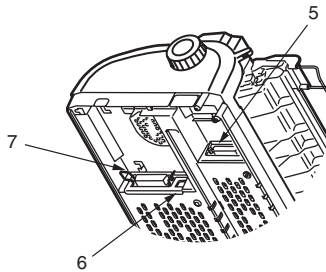

5. Serial connector: connect to serial interface cable.
6. USB connector: connect to USB interface cable.
7. Parallel connector: connect to parallel interface connector.

## LOCATING YOUR PRINTER

- > Select a firm, solid, level surface on which to site your printer.
- > Allow enough space around your printer (e.g. at least 60 cm from any wall) for easy access to the Platen Knob and the various paper feed paths.

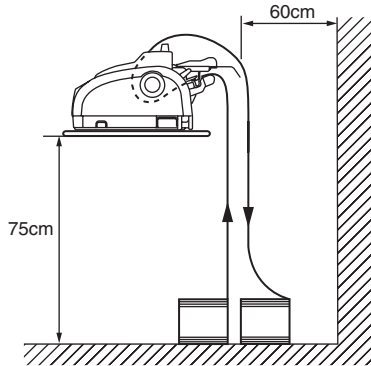

- > Make sure a grounded power outlet is available nearby.

## POWERING ON YOUR PRINTER

1. Ensure that your printer Power Switch is set to OFF.

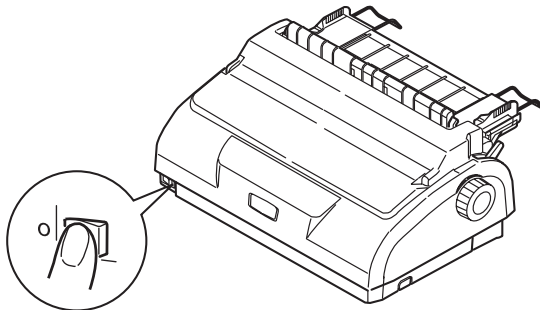

2. Connect the power cable (1) to the power connector (2) on the printer.

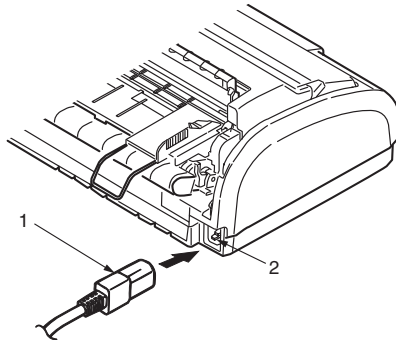

3. Connect the power cable to a 220/240 V AC power outlet and switch on the outlet power.
4. Turn the printer Power Switch to ON.



5. Check that the SEL and STATUS indicators on the control panel illuminate.

## PRODUCING A TEST PRINT

To check that your printer is operational, produce a test print on a sheet of 80 gsm A4 paper (for example) as follows:

### CAUTION!

**Allow at least 5 seconds between turning the printer ON after turning it OFF. A shorter time interval between turning ON/OFF operations may cause printer power failure.**

**Do not turn the printer OFF while it is printing as this may result in damage to the print head.**

1. Turn the printer Power Switch to OFF.
2. Set the Paper Type Lever to cut sheet.
3. Remove the Top Cover and set the Paper Thickness Lever to position 1.
4. Press and hold the LF/FF and the LOAD/EJECT buttons and turn the Power Switch to ON. The amber ALARM indicator should be illuminated to indicate that there is no paper in the printer.
5. With the long side of the paper against the paper guide, insert the paper carefully into the printer. The printer will automatically grip the paper and start the test print.

---

*NOTE*

*If required, you can pause the test print by pressing the SEL button and then resume the test print by again pressing the SEL button.*

---

6. When the test print has completed, the paper is automatically ejected.

---

*NOTE*

*If you want to stop the test print for any reason, press the SEL button followed by the LOAD/EJECT button to eject the paper. Turn the printer Power Switch to OFF.*

---

# CONNECTING TO A COMPUTER

In this section you will interconnect your printer and computer, install the printer driver in your computer and print a test page.

## INTERFACES

Your printer is equipped with three data interfaces:

### CAUTION!

**Do not use more than one of the following data interface methods to connect to your PC.**

- > Parallel: for direct connection to a PC. This port requires a bi-directional (IEEE 1284 compliant) parallel cable.
- > Serial: for direct connection to a PC. This port requires a bi-directional RS232C serial interface cable.
- > USB: for connection to a PC running Windows 98 or above. This port requires a shielded cable less than 5m long conforming to USB version 2.0.

---

#### NOTE

*Interface cables are not supplied with your printer.*

---

## INTERCONNECTION

1. Ensure that both printer and computer are turned OFF.
2. Connect the required interface cable, serial (1), USB (2), or parallel (3), to the printer and then to the computer.

Break off the tabs (4) to allow the cables to sit neatly underneath the printer.

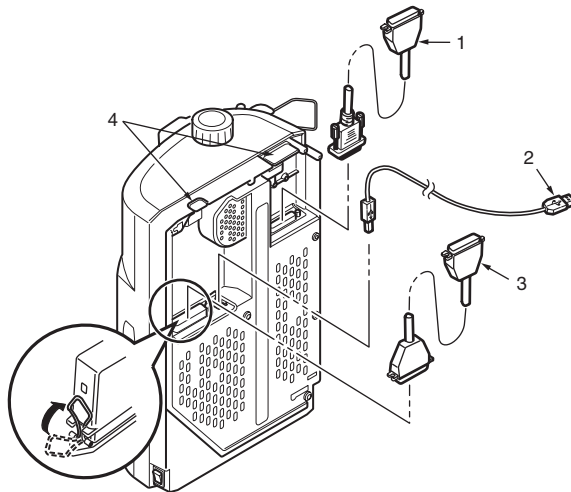

3. Turn ON the printer.
4. Turn ON the computer.

## INSTALLING THE PRINTER DRIVER

Insert the Drivers CD into your computer and follow the on-screen instructions to install the printer driver for use with your printer.

## PRINTING A TEST PAGE

As an example, using Windows XP:

1. Use Start > Printers and Faxes to show the Printers and Faxes window.
2. Highlight the driver for your printer.
3. Use File > Properties to show the Properties window.
4. On the General tab, click the Print Test Page button.
5. Ensure that a test page has printed, verifying your printer - computer setup.



## **P**rinting from a computer

When printing to your printer from, for example, a Windows application on your computer, make your printing selections from the driver windows that appear on screen. These driver windows have been designed to be easy to use and intuitive while supplementary on-line help is available by clicking each window Help button.

# UTILITIES

## OVERVIEW

The following utilities are available for your printer.

### Dot Impact Printer Utilities (OKI DIPUS)

- Status Monitor
- Menu Setup Utility
- Top of Form Setup Utility
- Switch Setup Utility

## ACCESSING

You may access the utilities

via the CD shipped with the printer

Here is a list of the utilities provided on the CD shipped with your printer.

### Dot Impact Printer Utilities (OKI DIPUS)

- Status Monitor
- Menu Setup Utility
- Top of Form Setup Utility
- Switch Setup Utility

## DESCRIPTION OF UTILITIES

### 1. OKI DIPUS (Dot Impact Printer Utilities)

This is a set of utilities that allow you to control the printer from your computer. These utilities support Windows operating systems using parallel, USB, or network connections. See the help for details on using these utilities.

The utilities are:

- Status Monitor
- Menu Setup Utility
- Top of Form Setup Utility
- Switch Setup Utility

## **INSTALLING THE UTILITIES**

### **WINDOWS**

#### **Utilities on the CD**

Load the utilities from the CD supplied with your printer.

## **OKI DIPUS (DOT IMPACT PRINTER UTILITIES)**

### **GENERAL INFORMATION**

This is a set of utilities that allow you to control the printer from your computer. These utilities support Windows operating systems using parallel, USB, or network connections.

The utilities are:

- Status Monitor
- Menu Setup Utility
- Top of Form Setup Utility
- Switch Setup Utility

### **HOW TO INSTALL**

Start setup.exe in the "Service/Utilities/OKI DIPUS" folder of the CD.

### **ADDITIONAL INFORMATION**

See the Help for details on using these utilities.

### **STATUS MONITOR**

The Status Monitor is a small background program that keeps track of the state of your printer. It tells you when the printer is functioning normally, when there is a problem, such as a paper jam or communication error, and when consumables are running low.

Normally, the Status Monitor appears on the task bar as an icon, which changes color to show the printer's status. You can set it to pop up in a window when an alert or error condition occurs.

### **MENU SETUP UTILITY**

This utility lets you change your printer's menu settings from your computer. You can also save frequently-used settings to a file on your computer for quick resetting.

### **TOP OF FORM SETUP UTILITY**

This utility lets you set the top of form from your computer for each available paper path. You can also save frequently-used settings to a file on your computer for quick resetting.

### **BUTTON SETUP UTILITY**

This utility lets you disable buttons on the printer from your computer. It is mainly for use by administrators to keep multiple users from accidentally changing settings on the printer.

# PAPER HANDLING

This section describes how to use cut sheet paper and continuous forms in your printer.

## LOADING CUT SHEET PAPER

1. Ensure that the printer is turned ON.

---

*NOTE*

*If there are any continuous forms in the printer, eject them as described in "Removing continuous forms" on page 32.*

---

2. Ensure the Paper Type Lever (1) is set to Cut Sheet .

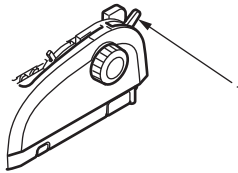

3. Set the left paper margin by adjusting the Paper Guide (1). Position the edge of the Paper Guide (1) at the tip of the Printed Line Marker arrow (2) on the Paper Tray.

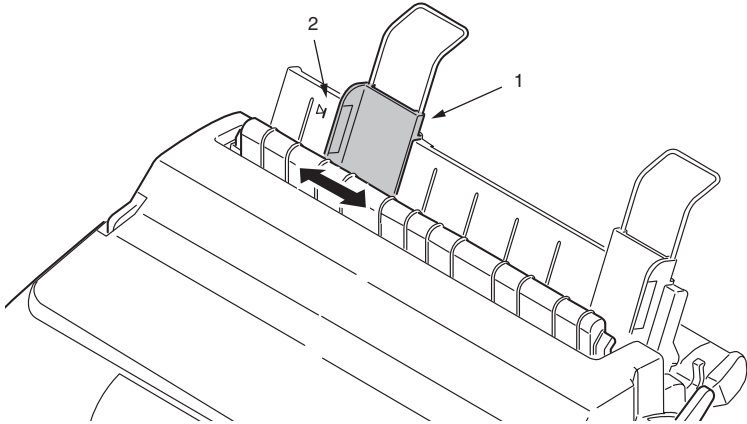

4. Remove the Top Cover and set the Paper Thickness Lever (1) to suit the paper. See "[Setting the Paper Thickness lever](#)" on page 41.

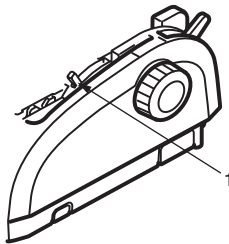

### CAUTION!

If the Paper Thickness Lever setting does not match the paper being used, paper feeding and printing may not work properly.

5. With the printing side facing downwards, into the printer and the left edge aligned with the Paper Guide (1), carefully insert the paper on the Paper Tray (2) into the printer until it is gripped. Insert the paper with both hands and push it in gently.

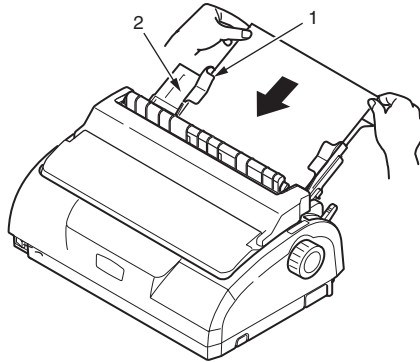

---

**NOTE**

- *When a pasted billing slip is peeled off and used, bending of the sheet may occur after printing (or at the time of feeding) due to the paste remaining on the top of the slip. So, at the time of peeling off, remove the paste and straighten out the curl.*
  - *Crease may occur when thinner media than standard ones like A4 feather paper are used.*
  - *When thin media are used, the sheet may be rolled into the roller after ejecting. Remove the ejected paper before starting the next printing, or the ejected paper may be rolled into the roller.*
  - *Do not print on the printing prohibited portion at the bottom of the paper. Such printing may result in irregular printing, damage to the media or jam.*
  - *Ensure that the paper is accurately aligned along the Paper Guide to avoid the possibility of skew printing.*
  - *When printing an envelope, do not fold up the flap. A flap aligned along the Paper Guide can lead to skew printing.*
-

## EJECTING CUT SHEET PAPER

When the printer reaches the end of the cut sheet page it automatically ejects the page. If required, add another sheet for the printer to continue printing from where it left off.

To eject a cut sheet left in the printer, carry out the following:

1. Press the SEL button to put the printer off-line.
2. Press the LOAD/EJECT button and the paper is ejected to the Paper Tray.

---

### *NOTE*

*Paper longer than A4 length (297 mm) may overlap and possibly fall off the Paper Tray.*

---



## LOADING CONTINUOUS FORMS

### SETTING UP CONTINUOUS FORMS

To avoid paper feeding problems, carry out the following:

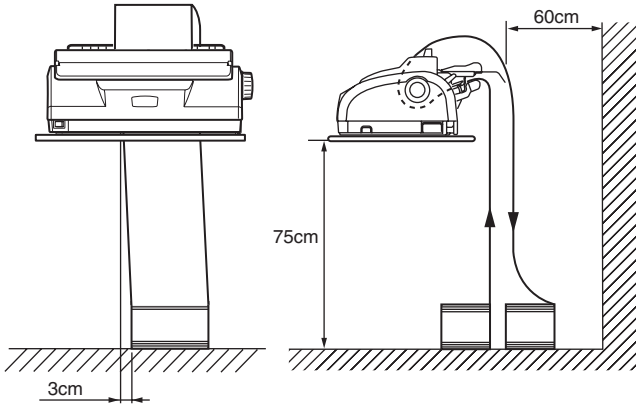

1. Check your printer is on a surface approximately 75 cm above the floor.
2. Position the continuous forms supply directly below the printer, no more than 3 cm left or right of the printer paper path.
3. Ensure the rear of the printer is close to and parallel with the edge of the surface and at least 60 cm from any wall.

### FEEDING CONTINUOUS FORMS

1. Ensure that the printer is turned ON.

---

#### NOTE

If there is a cut sheet in the printer, eject it as described in "[Ejecting cut sheet paper](#)" on page 24.

---

2. Set the Paper Type Lever to Continuous Forms .

3. Remove the Top Cover and set the Paper Thickness Lever (1) to suit the paper. See "[Setting the Paper Thickness lever](#)" on page 41.

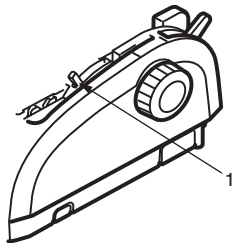

---

**NOTE**

*If the Paper Thickness Lever setting does not match the paper being used, paper feeding and printing may not work properly.*

---

4. Remove the Paper Tray and Input Tray together, by gripping the Input Tray at both sides and pulling it up and away from the printer.

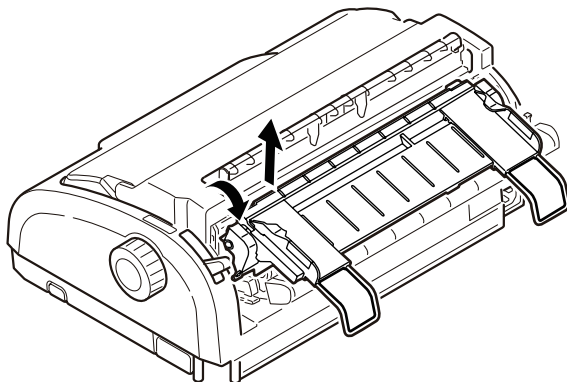

5. Lift the locking lever (1) of the left Pin Tractor and slide the Pin Tractor as required to adjust the paper position.

Press the locking lever back down to lock the Pin Tractor in the desired position.

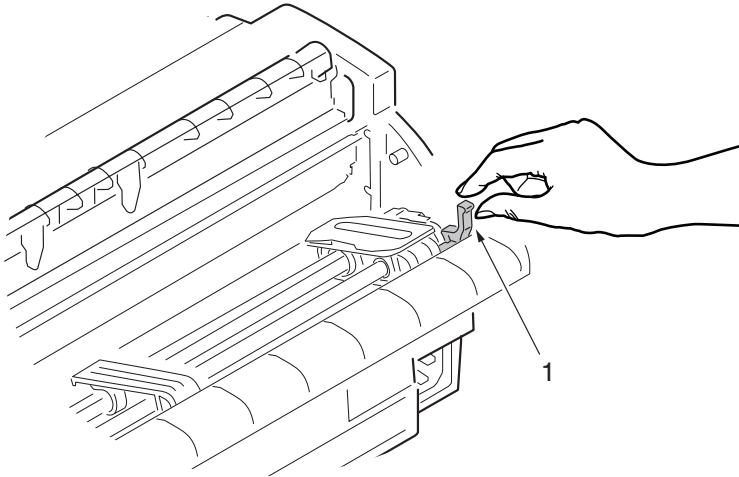

6. Lift the locking lever (1) of the right Pin Tractor and slide the Pin Tractor to the required position to accommodate the width of the continuous forms to be used. Move the rear paper guide (2) to midway between the left (3) and right (4) Pin Tractors.

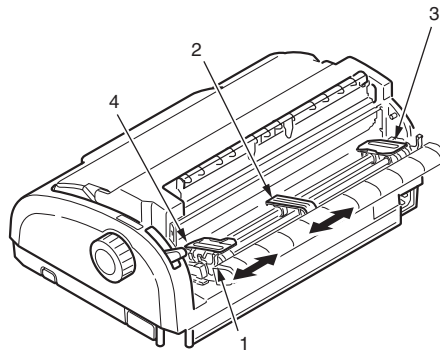

7. Open the left and right Pin Tractor covers and feed the continuous forms in the direction of the arrows, locating the sprocket holes in the forms onto the sprocket pins.

Ensure that the forms are properly aligned on the sprocket pins, then close the covers.

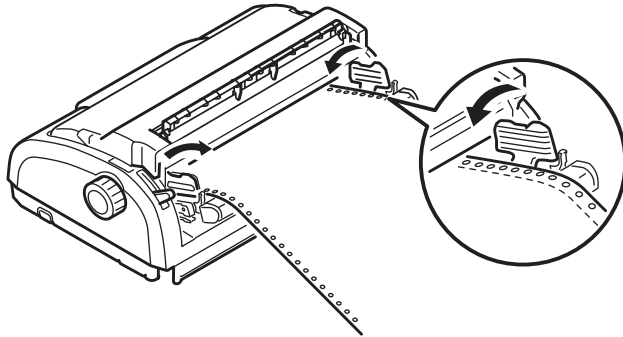

8. Adjust the right Pin Tractor to accommodate the width of the continuous forms, taking care that the forms are held neither too loosely nor too tightly between the Pin Tractors. Press the locking lever down to lock the right Pin Tractor in the desired position.

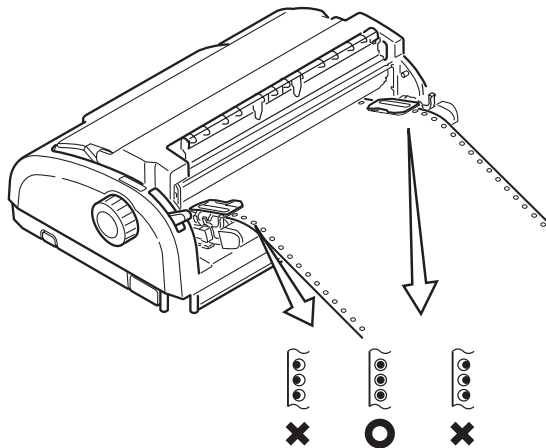

9. Replace the Input Tray and Paper Tray by fitting the Input Tray into the gooves at the back of the printer and pushing gently forward until the tray clips into place.

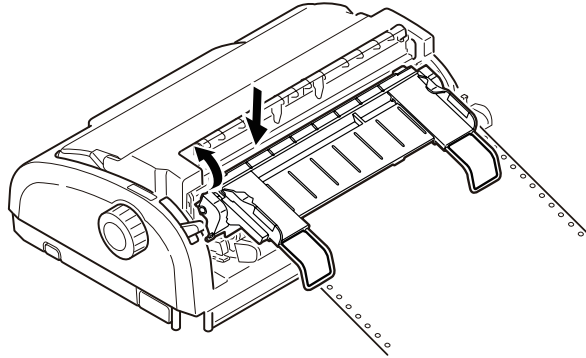

10. Press the LOAD/EJECT button. The continuous forms will be taken into the printer and positioned at the first line print position and the SEL indicator will illuminate.

---

**NOTE**

- *Specific kind of media may affect the accuracy of relining due to passage load of the media. In this case, use the printer with Paper Guide erected.*
- *Specific kind of media may cause slipping and the last sheet may not be ejected. Confirm well before using.*

Paper Guide:  
normal

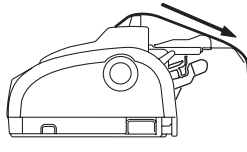

Paper Guide; erected  
(Relining accuracy will be improved.)

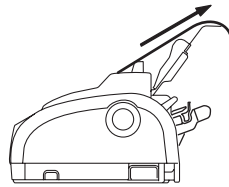

- *When using Bottom Tractor, parts of sheets put together by the stapler may stick together, thus feeding two pages at the same time, resulting in paper jam. In this case, unfasten the pile of sheets before feeding. Further, if jams occur due to the pile of the paper, use of Rear Tractor is recommended.*
- *When continuous paper of 3-4" width is used, move Paper Guide (L) to the middle of the paper.*

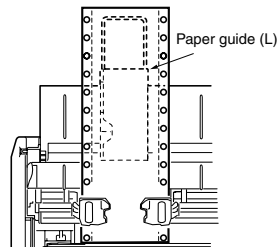

- *Under the circumstance of high temperature and high humidity, the paper become frail and galley of sprocket hole and paper jam tend to occur.*

*When the paper is to be set in Tractor, adjust the position of Tractor so that will not get loose or too tense. (Fit the pin of Tractor with the center of the sprocket hole.)*

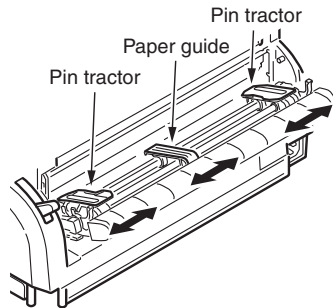

## TEARING OFF CONTINUOUS FORMS

1. With the SEL indicator illuminated, press and hold the LF/FF button to move the continuous form to the next page.
2. Press TEAR to align the tear-off perforations on the form with the paper cutter on the printer.
3. Carefully tear off the forms along the tear-off perforations using the paper cutter as a guide. Using excessive force may result in tearing at a position other than the tear-off perforations.
4. Press the TEAR button to reposition the continuous forms in the printer back to the first line print position.

## ALIGNING THE TEAR-OFF PERFORATIONS

If the tear-off perforations are not aligned with the paper cutter, align them as follows:

1. Remove the Top Cover of your printer.
2. With the SEL indicator illuminated, press and hold the TEAR button to move the tear-off perforations to the paper cutter.

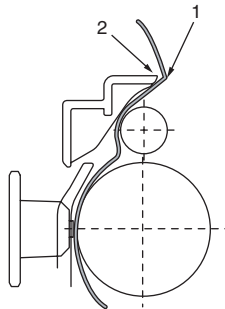

3. Check the position of the tear-off perforations (1) relative to the paper cutter (2).
  - (a) To advance the forms, continue to hold down the TEAR button and then the SEL button.

- (b) To retract the forms, continue to hold down the TEAR button and the LF/FF button.

---

**NOTE**

*If a movement greater than  $\pm 0.18$  mm (1/144 in) for ML1120 and  $\pm 0.14$  mm (1/180 in) for ML1190 is specified, the above adjustment cannot be made.*

---

4. Release the buttons after the tear-off perforations have been aligned with the paper cutter.

## REMOVING CONTINUOUS FORMS

1. Tear off the continuous forms. See ["Tearing off continuous forms" on page 31](#).
2. Press the SEL button to set the printer off-line and reposition the continuous forms in the printer.
3. Press the LOAD/EJECT button to move the front edge of the continuous forms backwards to the Pin Tractors.

---

**NOTE**

*If sprocket holes of the last page of the forms disengage from the sprocket pins, do not attempt to eject the paper to avoid the possibility of a paper jam.*

---

4. Remove the Input Tray by gripping it at both sides and pulling it up and away from the printer.

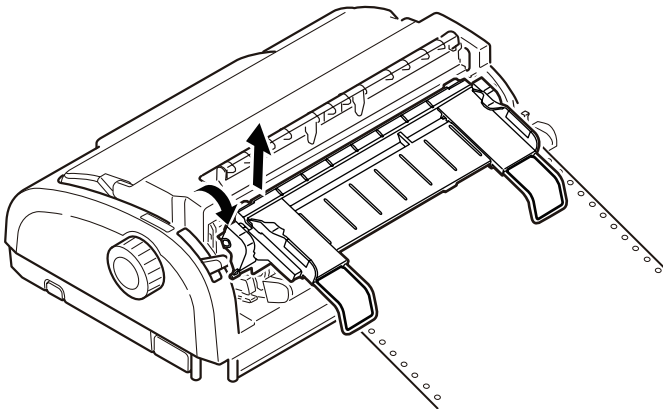



5. Lift the Pin Tractor covers and remove the forms.

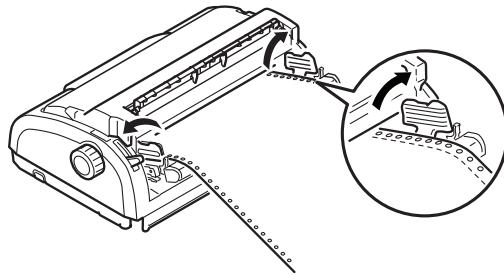

6. Close the Pin Tractor covers.
7. Replace the Input Tray and Paper Tray by fitting the Input Tray into the gooves at the back of the printer and pushing gently forward until the tray clips into place.

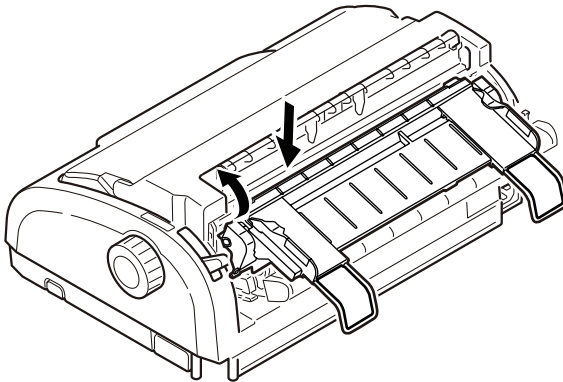

## HOW TO USE BOTTOM TRACTOR

1. Remove the access cover.

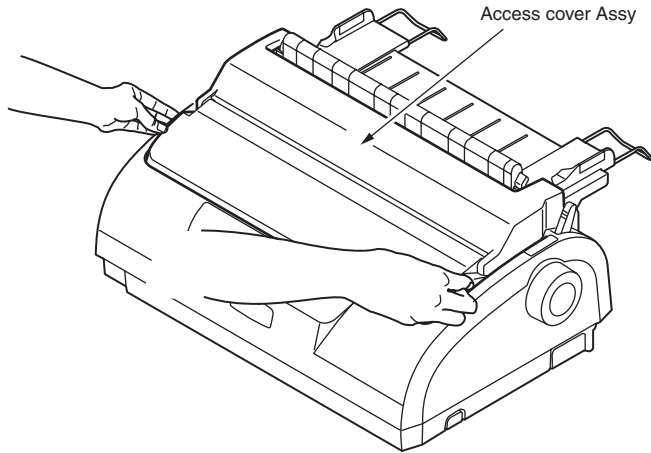

2. Remove the pull up Assy.

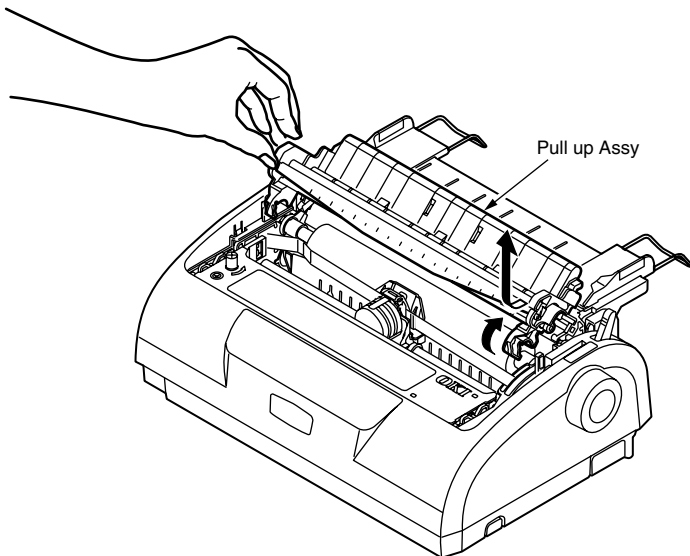

3. Remove the sheet guide Assy.

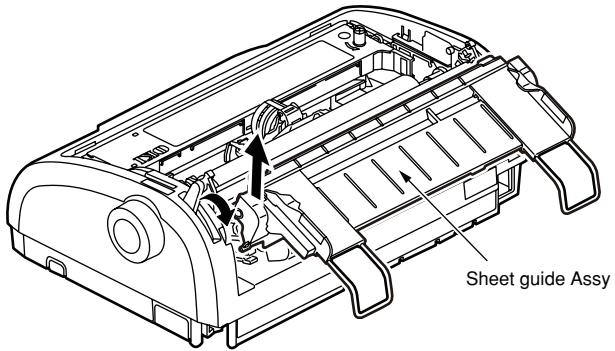

4. Remove the left and right knobs of the tractor Assy.

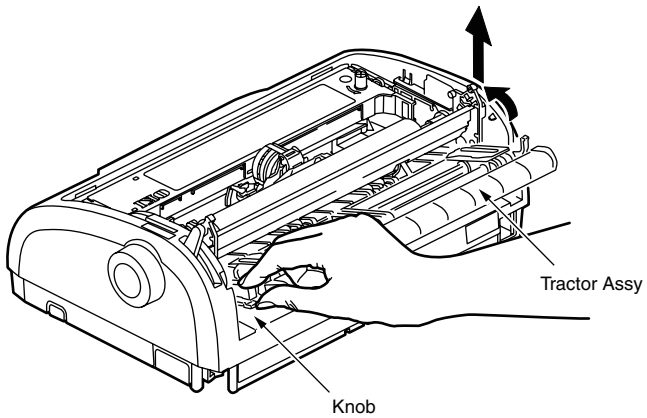

5. Fix the sheet guide Assy.

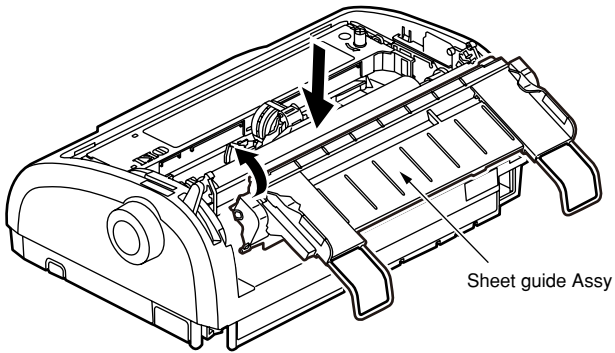

6. Fit the U ditch of the tractor Assy to post, turn it in the direction of using the post as fulcrum and lock it to the printer proper.

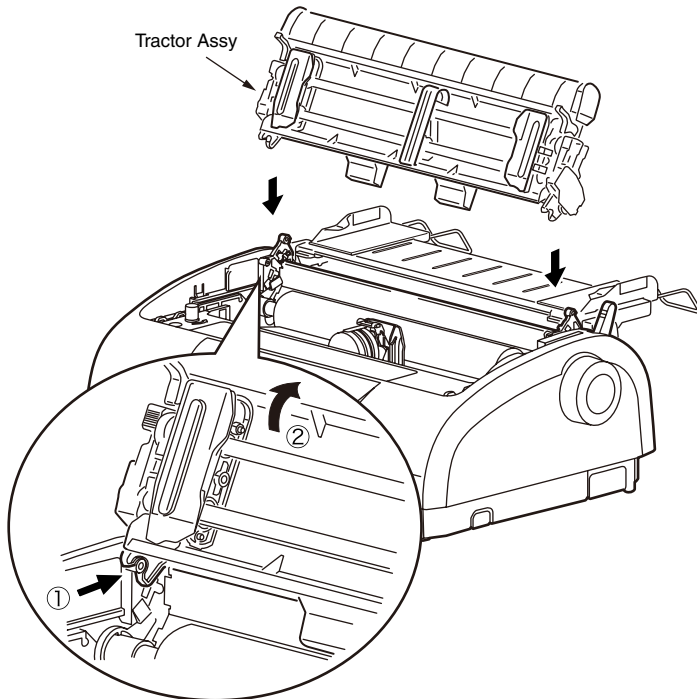

7. Insert the paper from the paper insertion opening as shown in the diagram.

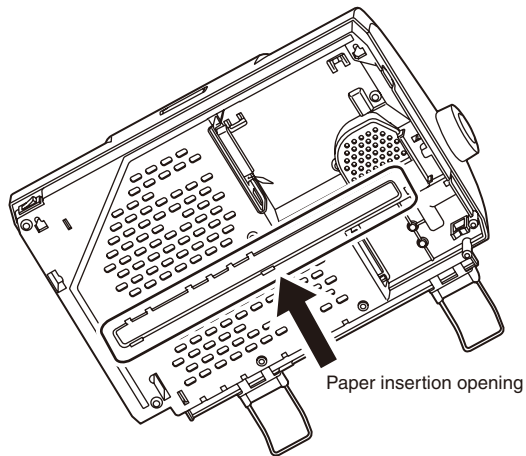

8. Set the paper to the tractor Assy. (As regards the ways of choosing the paper size and setting, see the paper setting of the rear tractor.)

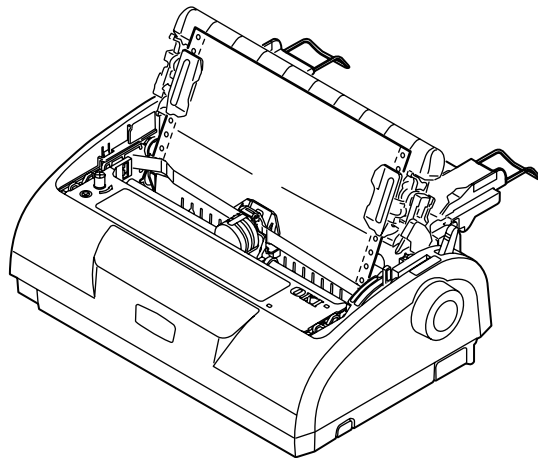

9. Turn the AC switch on, push down the LF/FF switch and align the heading position.

## CAUTION!

In aligning the heading position, if aligned by turning the platen knob in the direction of , the pitch between the first and second lines may get narrower. Be sure to finish aligning by pushing down the LF/FF switch.

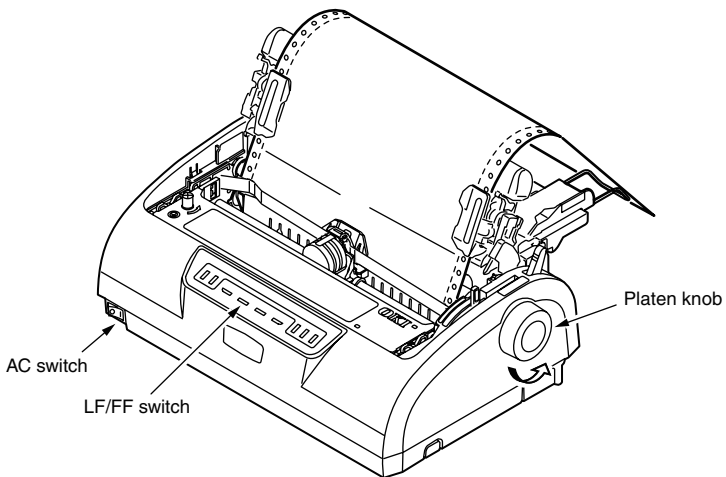

10. Move the cursor in conformity with the width of the paper.

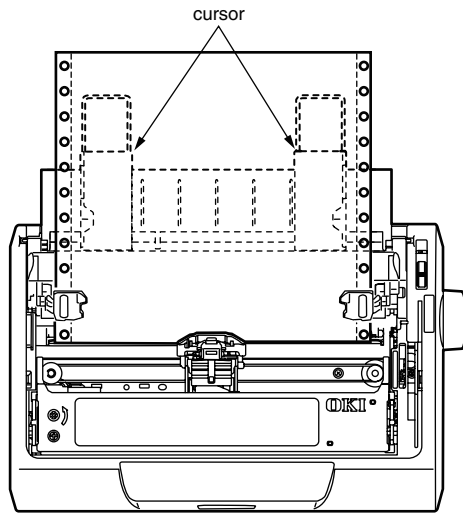

- \* When a sheet of narrow width is to be used, set the cursor as shown in the diagram.

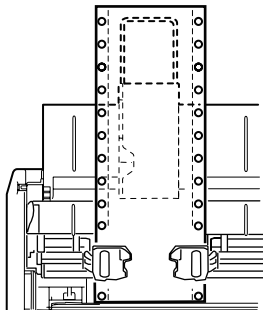

## CAUTION!

When to use the media of narrow width(3-4inches) by bottom tractor, set the media inside the platen. If the media is set outside the platen, a crease may occur to the paper.

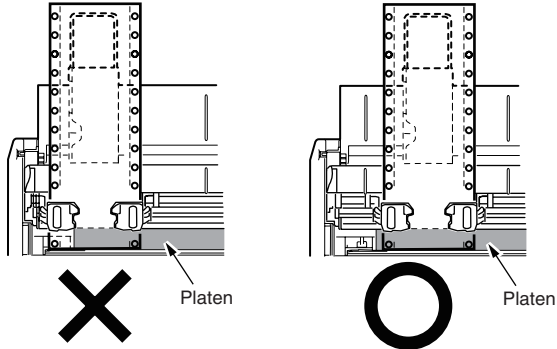

11. Fix the access cover Assy. (The access cover B will not close tightly.)

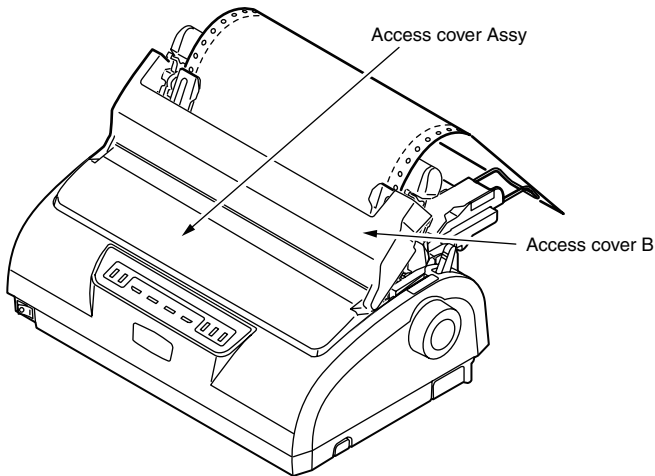



## SETTING THE PAPER THICKNESS LEVER

There are 6 lever positions, the first 5 for printing purposes and the sixth to facilitate ribbon replacement.

Set the Paper Thickness lever for different paper types as follows:

PAPER TYPE	LEVER POSITION				
	1	2	3	4	5 - 6
Cut sheet paper					See below
52 - 80 gsm	X				
81 - 127 gsm		X			
Envelope				X	
Carbon paper or Pressure- sensitive paper (40 gsm)					See below
2 part		X			
3 part		X			
4 part			X		
5 part				X	

Set the Paper Thickness lever for overall paper thickness as follows:

OVERALL PAPER THICKNESS	LEVER POSITION
0.06 - 0.10 mm	1
0.11 - 0.18 mm	2
0.19 - 0.25 mm	3
0.26 - 0.32 mm	4
0.33 - 0.39 mm	5
0.40 - 0.46 mm	6

# OPERATING INSTRUCTIONS





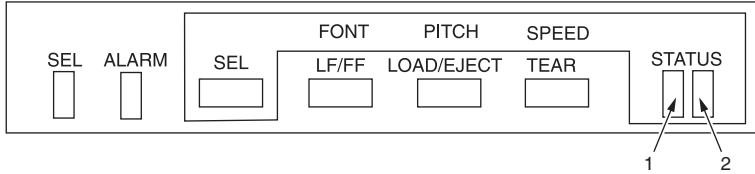

































## CONTROL PANEL

### ML1120



The status/alarm indicators and button switches on the control panel allow you to check printer status and control the printer.

## Indicators

INDICATOR	STATUS	MEANING
 SEL	 ON	Printer is on-line i.e. is available to print
	 OFF	Printer is off-line i.e. is not available to print
	 Flashing	<ul style="list-style-type: none"> <li>When flashing together with the ALARM indicator, printing cannot be resumed at this stage. Turn the power OFF, verify that the carriage moves properly, then turn the power ON again. If the problem is still there after you turn the power ON again, contact your dealer.</li> <li>Indicates Print Suppress status.</li> <li>Indicates Head Thermal Alarm status.</li> <li>Indicates Power Save mode (long-cycle flashing)</li> </ul>
 ALARM	 ON	If printing, indicates lack of paper, i.e. no paper present.
	 OFF	Paper present status
	 Flashing	<ul style="list-style-type: none"> <li>Paper jam alarm status</li> <li>Media switch alarm status</li> <li>When flashing together with the SEL indicator, printing cannot be resumed at this stage. Turn the power OFF, verify that the carriage moves properly, then turn the power ON again. If the problem is still there after you turn the power ON again, contact your dealer.</li> </ul>
  STATUS   ON  OFF  Flashing	Indicates font settings.	
	  : NLQ   : Utility   : HSD   : SSD	
	For character pitch setting:	
	  : 10CPI   : 12CPI   : 15CPI   : 17CPI   : 20CPI   : Proportional	
For print mode setting:		
  : Normal   : High-Speed   : Quiet		

**ML1190**

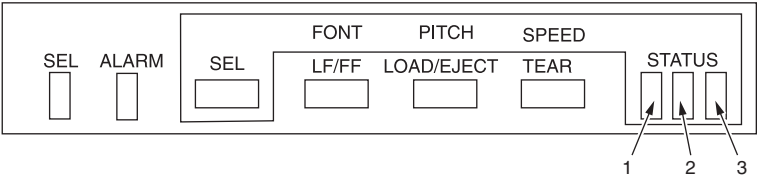

The status/alarm indicators and button switches on the control panel allow you to check printer status and control the printer.

## Indicators

INDICATOR	STATUS	MEANING
<input type="checkbox"/> SEL	<input checked="" type="checkbox"/> ON	Printer is on-line i.e. is available to print
	<input type="checkbox"/> OFF	Printer is off-line i.e. is not available to print
	<input type="checkbox"/> Flashing	<ul style="list-style-type: none"> <li>When flashing together with the ALARM indicator, printing cannot be resumed at this stage. Turn the power OFF, verify that the carriage moves properly, then turn the power ON again. If the problem is still there after you turn the power ON again, contact your dealer.</li> <li>Indicates Print Suppress status.</li> <li>Indicates Head Thermal Alarm status.</li> <li>Indicates Power Save mode (long-cycle flashing)</li> </ul>
<input type="checkbox"/> ALARM	<input checked="" type="checkbox"/> ON	If printing, indicates lack of paper, i.e. no paper present.
	<input type="checkbox"/> OFF	Paper present status
	<input type="checkbox"/> Flashing	<ul style="list-style-type: none"> <li>Paper jam alarm status</li> <li>Media switch alarm status</li> <li>When flashing together with the SEL indicator, printing cannot be resumed at this stage. Turn the power OFF, verify that the carriage moves properly, then turn the power ON again. If the problem is still there after you turn the power ON again, contact your dealer.</li> </ul>
<input type="checkbox"/> <input type="checkbox"/> <input type="checkbox"/> STATUS  <input checked="" type="checkbox"/> ON <input type="checkbox"/> OFF <input type="checkbox"/> Flashing	Indicates font settings. <input type="checkbox"/> <input type="checkbox"/> <input checked="" type="checkbox"/> : LQ Courier <input type="checkbox"/> <input checked="" type="checkbox"/> <input type="checkbox"/> : LQ Roman <input checked="" type="checkbox"/> <input type="checkbox"/> <input type="checkbox"/> : LQ Swiss <input type="checkbox"/> <input type="checkbox"/> <input checked="" type="checkbox"/> : LQ Swiss Bold <input type="checkbox"/> <input checked="" type="checkbox"/> <input type="checkbox"/> : LQ Orator <input checked="" type="checkbox"/> <input type="checkbox"/> <input type="checkbox"/> : LQ Gothic <input type="checkbox"/> <input checked="" type="checkbox"/> <input checked="" type="checkbox"/> : LQ Prestige <input type="checkbox"/> <input checked="" type="checkbox"/> <input type="checkbox"/> : Utility <input checked="" type="checkbox"/> <input type="checkbox"/> <input checked="" type="checkbox"/> : HSD  For character pitch setting: <input type="checkbox"/> <input type="checkbox"/> <input checked="" type="checkbox"/> : 10CPI <input type="checkbox"/> <input checked="" type="checkbox"/> <input type="checkbox"/> : 12CPI <input type="checkbox"/> <input type="checkbox"/> <input checked="" type="checkbox"/> : 15CPI <input type="checkbox"/> <input checked="" type="checkbox"/> <input type="checkbox"/> : 17CPI <input type="checkbox"/> <input checked="" type="checkbox"/> <input checked="" type="checkbox"/> : 20CPI <input type="checkbox"/> <input checked="" type="checkbox"/> <input type="checkbox"/> : Proportional	

## BUTTONS

BUTTON	STATUS	FUNCTION
SEL	On-line	Sets the printer to off-line.
	Off-line	Sets the printer to on-line and disarms the printer.
LF/FF	On-line and off-line	Feeds paper by one line. Holding the button down results in continuous form fed until first line of next page.
LOAD/EJECT	On-line and off-line Continuous Forms mode	Feed paper if it is not fed. If the continuous form is in position, press to retract the form to the Pin Tractors. (If the sprocket holes of the last page of the form disengage from the sprocket pins, do not attempt to eject the paper as a paper jam may result.)
	On-line and off-line Cut sheet manual mode	Ejects the cut sheet
TEAR	On-line and off-line Continuous Forms mode	Delivers the continuous form to the cut position. If the button is pressed again or data is received, the original form position is restored.
	On-line and off-line Cut sheet manual mode	Ineffective
SEL+POWER ON Switch		Enters menu mode.
LOAD/EJECT+SEL	On-line and off-line	Microfeed down 0.18 mm (1/144 in) for ML1120 and 0.14 mm (1/180 in) for ML1190 step.
LOAD/EJECT+LF/FF	On-line and off-line	Microfeed down 0.18 mm (1/144 in) for ML1120 and 0.14 mm (1/180 in) for ML1190 step.
TEAR+SEL	On-line and off-line	Microfeed down 0.18 mm (1/144 in) for ML1120 and 0.14 mm (1/180 in) for ML1190 step at tear-off position only.
TEAR+LF/FF	On-line and off-line	Microfeed down 0.18 mm (1/144 in) for ML1120 and 0.14 mm (1/180 in) for ML1190 step at tear-off position only.
SEL+TEAR	On-line and off-line	Quieter print mode Each press of the button pair progresses the printer through Quieter print mode > High multipart print mode > Normal print mode (Effective only for ML1120)

## SETTING MENU VALUES

The following information explains the printer settings and how you can change them. Printer items and their values are printed for reference.

### CONFIRMING CURRENT SETTINGS

To print the current menu settings, use a cut sheet of A4 paper or continuous forms of width at least 254 mm. In this example, a sheet of A4 paper is used.

1. Set the Paper Type lever to cut sheet mode.
2. To activate menu mode, carry out one of the following:  
While holding down the SEL button set the printer Power Switch to ON.
3. Place the cut sheet on the Paper Tray. The cut sheet passes through the printer. Once ejected, place the cut sheet in the Paper Tray again. The printer will print the first menu option.
4. Press the TEAR button to print out the current menu settings.
5. Exit or proceed to change menu settings:
  - (a) To exit menu settings confirmation, save the current settings and eject the paper, press LOAD EJECT continuously while pressing TEAR and press LF/FF .
  - (b) To change menu settings, see "[Menu setting](#)" on page 48.

## MENU SETTING

---

### *NOTE*

*Before changing menu settings, you may wish to print the current menu settings as in "Confirming current settings" on page 47.*

---

Set menu item values (printed out for reference as you proceed) as follows:

1. Press SEL and switch the printer ON to activate Menu mode.
2. Press SEL button (or TEAR and SEL button together) to step forward (backward) through the menu groups to the required group.
3. Press LF/FF button (or TEAR and LF/FF button together) to step forward (backward) through the menu items to the required item.
4. To change the setting for a selected item, press LOAD/EJECT (or TEAR and LOAD/EJECT button together) through the setting values to the required setting.
5. Repeat steps 2 and 3 as required to change settings for other items.
6. To exit menu setting, press LOAD EJECT continuously while pressing TEAR and press LF/FF to save the new settings and exit menu setting mode.

---

### *NOTE*

*Switching the printer OFF does not save the new settings.*

---



## ML1120

### Menu items and settings

In the menu settings tables below, factory default settings are shown in bold.

MENU	ITEM	FUNCTION	SETTING
Printer control menu	Emulation Mode	Select EPSON mode, IBM mode, or ML mode.	IBM <b>EPSON</b> ML
Font menu	Print Mode	Select quality of ANK characters.	NLQ Courier NLQ Gothic DRAFT <b>Utility</b>
	Draft Mode	Select HSD or SSD.	<b>HSD</b> SSD
	Pitch	Select character pitch.	<b>10 CPI</b> , 12 CPI, 15 CPI, 17.1 CPI, 20 CPI
	Proportional Spacing	Select whether to use proportional spacing or not.	Yes <b>No</b>
	Style	Select either font style.	<b>Normal</b> , Italics
	Size	Select the character scale size.	<b>Single</b> , Double
Symbol sets menu	Character Set	Select either ANK character code table.	Standard Line Graphics Block Graphics (displayed for ML emulation only)  <b>Set I</b> Set II (displayed for IBM and EPSON emulation only)
	Language Set	Select a language character set.	<b>American</b> , French, German, British, Danish I, Swedish, Italian, Spanish I, Japanese, Norwegian, Danish II, Spanish II, Latin American, French Canadian, Dutch, Publisher
	Zero Character	Select either print font pattern to receive a zero character located at 30H in ANK code or at AA30H in a single-byte code.	<b>Unslashed</b> Slashed

MENU	ITEM	FUNCTION	SETTING
Symbol sets menu	Code Page	Select a code page.	<b>USA</b> Canada French Multilingual Portugal Norway BRASCII Abicomp Multilingual 858 ISO 8859-15
Rear feed menu	Line Spacing	Select line feed pitch.	<b>6 LPI</b> 8 LPI
	Form Tear-Off	Select manual or auto as the method to advance a continuous form to the form tear-off position.	<b>Manual</b> 0.5 sec 1.0 sec 2.0 sec
	Skip Over Perforation	Select whether to skip over perforation or not. (When a skip over perforation setup command is received, the received command is given priority.)	25.4 mm(1 ") <b>No</b>
	Page Length	Select the length of a continuous form.	<b>279.4 mm(11 ")</b> 296.3 mm(11 2/3 ") 304.8 mm (12 ") 355.6 mm(14 ") 431.8 mm(17 ") 76.2 mm(3 ") 82.6 mm(3.25 ") 84.7 mm(10/3 ") 88.9 mm(3.5 ") 93.1 mm(11/3 ") 101.6 mm(4 ") 127.0 mm(5 ") 139.7 mm(5.5 ") 152.4 mm(6 ") 177.8 mm(7 ") 203.2 mm(8 ") 215.9 mm(8.5 ")
	Cut position adjust	Select an adjustment value for the position to cut the end of a continuous form. (In 1/144 in increments)	-20 - -1 <b>0</b> +20 - +1
	TOF adjust (continuous)	Select an adjustment value for the reference position in regard to the TOF position of a continuous form.  The position moves to the rear of the form by [+] and to the top of the form by [-] in 1/144 in increments.	-20 - -1 <b>0</b> +20 - +1

MENU	ITEM	FUNCTION	SETTING
Rear feed menu	Continuous paper top of form	Select the reference position for the TOF position when auto loading continuous form paper from the rear of the printer. (Up to the mid-section of characters in the first line.)	2.12 mm (1/12 ") 4.23 mm (1/6 ") 6.35 mm (1/4 ") 8.47 mm (1/3 ") 10.58 mm (5/12 ") 12.70 mm (1/2 ") 14.82 mm (7/12 ") 16.93 mm (2/3 ") 19.05 mm (3/4 ") 21.17 mm (5/6 ") <b>23.28 mm (11/12 ")</b> 25.40 mm (1 ") 27.52 mm (13/12 ") Use top of form
Bottom feed menu	Line Spacing	Select line feed pitch.	<b>6 LPI</b> 8 LPI
	Skip Over Perforation	Select whether to skip over perforation or not. (When a skip over perforation setup command is received, the received command is given priority.)	25.4 mm(1 ") <b>No</b>
	Page Length	Select the length of a continuous form.	<b>279.4 mm(11 ")</b> 296.3 mm(11 2/3 ") 304.8 mm (12 ") 355.6 mm(14 ") 431.8 mm(17 ") 76.2 mm(3 ") 82.6 mm(3.25 ") 84.7 mm(10/3 ") 88.9 mm(3.5 ") 93.1 mm(11/3 ") 101.6 mm(4 ") 127.0 mm(5 ") 139.7 mm(5.5 ") 152.4 mm(6 ") 177.8 mm(7 ") 203.2 mm(8 ") 215.9 mm(8.5 ")

MENU	ITEM	FUNCTION	SETTING
Top feed menu	Line Spacing	Select line feed pitch.	<b>6 LPI</b> 8 LPI
	Page Length	Select the page length of cut paper.	279.4 mm(11 ") <b>296.3 mm(11 2/3 ")</b> 304.8 mm (12 ") 355.6 mm(14 ") 431.8 mm(17 ") 76.2 mm(3 ") 82.6 mm(3.25 ") 84.7 mm(10/3 ") 88.9 mm(3.5 ") 93.1 mm(11/3 ") 101.6 mm(4 ") 127.0 mm(5 ") 139.7 mm(5.5 ") 152.4 mm(6 ") 177.8 mm(7 ") 203.2 mm(8 ") 215.9 mm(8.5 ")
	Top feed wait time	Select the waiting time between setting paper on the tray and feeding it while the printer is waiting for paper to be fed in cut-paper manual feed mode.	Invalid 0.5 sec <b>1.0 sec</b> 2.0 sec
	Page length control	Control the page length of cut paper.	by MENU setting <b>by Actual page length</b>
	Cut sheet auto eject Position	Select a printable area at the bottom of cut sheets of paper in cut-paper mode (the character centre position).	<b>6.35 mm (3/12 ")</b> 12.70 mm(6/12 ") 14.82 mm (7/12 ")
	TOF adjust (Cut Sheet)	Select an adjustment value for the reference position in regard to the TOF position of cut-paper/passbooks.  The position moves to the rear of the form by [+] and to the top of the form by [-] in 1/144 in increments.	-20 - -1 <b>0</b> +20 - +1

MENU	ITEM	FUNCTION	SETTING
Top feed menu	Cut sheet top of form	Select the reference position for the TOF position when feeding cut-paper in manual mode. (Up to the mid-section of characters in the first line.)	2.12 mm (1/12 ") 4.23 mm (1/6 ") 6.35 mm (1/4 ") 8.47 mm (1/3 ") 10.58 mm (5/12 ") 12.70 mm (1/2 ") 14.82 mm (7/12 ") 16.93 mm (2/3 ") 19.05 mm (3/4 ") 21.17 mm (5/6 ") <b>23.28 mm (11/12 ")</b> 25.40 mm (1 ") 27.52 mm (13/12 ") Use top of form
	Cut sheet LF adjust	Adjust a line feed amount in cut-paper mode.	-14 - -1 <b>0</b> +14 - +1
Set-up menu	Graphics	Select the printing direction when bit image graphics print data exists in a line.	<b>Bi-directional</b> Uni-directional
	7 or 8 Bits Graphics	Set the graphics data unit to 7 or 8 bits. (ML emulation only)	<b>8</b> <b>7</b>
	Receive buffer size	Select size of the received buffer.	1line 32 K <b>64 K</b>
	Paper out override	Select whether to detect paper end or not.	<b>No</b> Yes
	Print Registration 1	Adjust the print starting position on printing in the reverse direction. (The position moves to the right or left in 1/720 in increments.)	-10 - -1 <b>0</b> +10 - +1
	Print Registration 2	Adjust the print starting position on printing in the reverse direction. (The position moves to the right or left in 1/720 in increments.)	-10 - -1 <b>0</b> +10 - +1
	Print Registration 3	Adjust the print starting position on printing in the reverse direction. (The position moves to the right or left in 1/720 in increments.)	-10 - -1 <b>0</b> +10 - +1

MENU	ITEM	FUNCTION	SETTING
Set-up menu	7 or 8 Bits Data Word	Set the character code and graphics data units to 7 or 8 bits. (ML emulation only)	<b>8</b> 7
	Operator panel function	Select full or limited operation.	<b>Full operation</b> Limited operation
	Reset inhibit	Set whether to enable or disable an initial command.	<b>No</b> Yes
	Print suppress effective	Set whether to enable or disable a print suppress setup command.	<b>Yes</b> No
	Auto LF	Select whether to perform auto LF operation or not upon receiving a CR code.	Yes <b>No</b>
	Auto CR	Select whether to perform auto CR operation upon receiving a carriage return command. (IBM emulation only)	Yes <b>No</b>
	Print DEL Code	Set whether 7FH code is printed with DEL mark or not. (ML emulation only)	<b>No</b> Yes
	SI select pitch (10 CPI)	Set how to handle an SI command received in 10 CPI mode. (IBM emulation only)	15 CPI <b>17.1 CPI</b>
	SI select Pitch (12 CPI)	Set how to handle an SI command received in 12 CPI mode. (IBM emulation only)	<b>12 CPI</b> 20 CPI
	Time out print	Select valid or invalid.	<b>Valid</b> Invalid
	Auto Select	Select whether to automatically set Select Mode after paper feeding or not.	<b>Yes</b> No
	Host Interface	Select interface settings.	<b>Auto Interface</b> Parallel USB Serial

MENU	ITEM	FUNCTION	SETTING
Set-up menu	I/F Time out	Select timeout time for auto interfacing.	<b>15 sec</b> 30 sec 45 sec 1 min 2 min 3 min 4 min 5 min
	ESC SI Pitch	Set the contents of ESC SI commands. (IBM emulation only)	<b>17.1 CPI</b> 20 CPI
	Print Style	Set quiet printing and print speed.	<b>Normal</b> High Speed Quiet
	Select quiet mode	Select the type of quiet mode.	<b>Mode 1</b> Mode 2
	Reverse Feed Control	Set reverse feeding.	<b>TOF stop</b> TOF over
	Centering position (continuous)	Set the centering position for the print head by the number of characters of 10CPI ANK.	<b>Default</b> Mode1 Mode2
	Centering position (cut sheet)	Set the centering position for the print head by the number of characters of 10CPI ANK.	<b>Default</b> Mode1 Mode2
	Power Save Time	Select the time to enter the Power Save mode.	<b>5 min</b> 10 min 15 min 30 min 60 min
Paper End	Select whether a printer status where no paper is loaded is set to SEL or DESEL.	<b>On-line</b> Off-line	

MENU	ITEM	FUNCTION	SETTING
Parallel I/F	I-Prime	Set I-Prime signal control of the Centronics interface.	Invalid <b>Buffer Print</b> Buffer Clear
	Auto Feed XT	Set whether to enable or disable Auto Feed XT signal of the Centronics interface. (EPSON emulation only)	Valid <b>Invalid</b>
	Bi-Direction	Set whether to enable or disable Two-way communication of the Centronics interface.	<b>Enable</b> Disable
Serial I/F	Parity	Set parity.	<b>None</b> Odd Even Ignore
	Serial Data 7/8 Bits	Set serial data length.	<b>8 bit</b> 7 bit
	Protocol	Set protocols.	<b>DTR</b> X-ON/X-OFF DTR & X-ON/X-OFF
	Diagnostic Test	Set/Cancel loop testing of the serial interface.	<b>No</b> Yes
	Baud Rate	Set the transmission speed of the serial interface.	9,600 bps 4,800 bps 2,400 bps 1,200 bps 600 bps 300 bps <b>19,200 bps</b>
	DTR Signal	Set whether to switch the DTR signal of the serial interface by Select/Deselect or hold it after power-on.	<b>Ready on Power UP</b> Ready on Select
	Busy Time	Set the minimum time it takes to switch from a busy state to a ready state.	<b>0.2 sec</b> 1.0 sec



## ML1190

### Menu items and settings

In the menu settings tables below, factory default settings are shown in bold.

MENU	ITEM	FUNCTION	SETTING
Printer control menu	Emulation Mode	Select EPSON LQ mode, IBM PPR mode, or IBM AGM mode.	<b>EPSON LQ</b> IBM PPR IBM AGM
Font menu	Print Mode	Select quality of ANK characters.	<b>LQ Courier</b> LQ Roman LQ Swiss LQ Swiss Bold LQ Orator LQ Gothic LQ Prestige Utility HSD
	Pitch	Select character pitch.	<b>10 CPI</b> , 12 CPI, 15 CPI, 17.1 CPI, 20 CPI
	Proportional Spacing	Select whether to use proportional spacing or not.	Yes <b>No</b>
	Style	Select either font style.	<b>Normal</b> , Italics
	Size	Select the character scale size.	<b>Single</b> , Double
Symbol sets menu	Character Set	Select either ANK character code table.	<b>Set I</b> Set II
	Language Set	Select a language character set.	<b>American</b> , French, German, British, Danish I, Swedish, Italian, Spanish I, Japanese, Norwegian, Danish II, Spanish II, Latin American, French Canadian, Dutch, Publisher
	Zero Character	Select either print font pattern to receive a zero character located at 30H in ANK code or at AA30H in a single-byte code.	Unslashed <b>Slashed</b>

MENU	ITEM	FUNCTION	SETTING
Symbol sets menu	Code Page	Select a code page.	<b>USA</b> Canada French Multilingual Portugal Norway BRASCII Abicomp Multilingual 858 ISO 8859-15
Rear feed menu	Line Spacing	Select line feed pitch.	<b>6 LPI</b> 8 LPI
	Form Tear-Off	Select manual or auto as the method to advance a continuous form to the form tear-off position.	<b>Manual</b> 0.5 sec 1.0 sec 2.0 sec
	Skip Over Perforation	Select whether to skip over perforation or not. (When a skip over perforation setup command is received, the received command is given priority.)	25.4 mm(1 ") <b>No</b>
	Page Length	Select the length of a continuous form.	<b>279.4 mm(11 ")</b> 296.3 mm(11 2/3 ") 304.8 mm (12 ") 355.6 mm(14 ") 431.8 mm(17 ") 76.2 mm(3 ") 82.6 mm(3.25 ") 84.7 mm(10/3 ") 88.9 mm(3.5 ") 93.1 mm(11/3 ") 101.6 mm(4 ") 127.0 mm(5 ") 139.7 mm(5.5 ") 152.4 mm(6 ") 177.8 mm(7 ") 203.2 mm(8 ") 215.9 mm(8.5 ")
	Cut position adjust	Select an adjustment value for the position to cut the end of a continuous form. (In 1/180 in increments)	-30 - -1 <b>0</b> +30 - +1
	TOF adjust (continuous)	Select an adjustment value for the reference position in regard to the TOF position of a continuous form.  The position moves to the rear of the form by [+] and to the top of the form by [-] in 1/180 in increments.	-30 - -1 <b>0</b> +30 - +1

MENU	ITEM	FUNCTION	SETTING
Rear feed menu	Continuous paper top of form	Select the reference position for the TOF position when auto loading continuous form paper from the rear of the printer. (Up to the mid-section of characters in the first line.)	2.12 mm (1/12 ") 4.23 mm (1/6 ") 6.35 mm (1/4 ") 8.47 mm (1/3 ") 10.58 mm (5/12 ") 12.70 mm (1/2 ") 14.82 mm (7/12 ") 16.93 mm (2/3 ") 19.05 mm (3/4 ") 21.17 mm (5/6 ") <b>23.28 mm (11/12 ")</b> 25.40 mm (1 ") 27.52 mm (13/12 ") Use top of form
Bottom feed menu	Line Spacing	Select line feed pitch.	<b>6 LPI</b> 8 LPI
	Skip Over Perforation	Select whether to skip over perforation or not. (When a skip over perforation setup command is received, the received command is given priority.)	25.4 mm(1 ") <b>No</b>
	Page Length	Select the length of a continuous form.	<b>279.4 mm(11 ")</b> 296.3 mm(11 2/3 ") 304.8 mm (12 ") 355.6 mm(14 ") 431.8 mm(17 ") 76.2 mm(3 ") 82.6 mm(3.25 ") 84.7 mm(10/3 ") 88.9 mm(3.5 ") 93.1 mm(11/3 ") 101.6 mm(4 ") 127.0 mm(5 ") 139.7 mm(5.5 ") 152.4 mm(6 ") 177.8 mm(7 ") 203.2 mm(8 ") 215.9 mm(8.5 ")

MENU	ITEM	FUNCTION	SETTING
Top feed menu	Line Spacing	Select line feed pitch.	<b>6 LPI</b> 8 LPI
	Page Length	Select the page length of cut paper.	279.4 mm(11 ") <b>296.3 mm(11 2/3 ")</b> 304.8 mm (12 ") 355.6 mm(14 ") 431.8 mm(17 ") 76.2 mm(3 ") 82.6 mm(3.25 ") 84.7 mm(10/3 ") 88.9 mm(3.5 ") 93.1 mm(11/3 ") 101.6 mm(4 ") 127.0 mm(5 ") 139.7 mm(5.5 ") 152.4 mm(6 ") 177.8 mm(7 ") 203.2 mm(8 ") 215.9 mm(8.5 ")
	Top feed wait time	Select the waiting time between setting paper on the tray and feeding it while the printer is waiting for paper to be fed in cut-paper manual feed mode.	Invalid 0.5 sec <b>1.0 sec</b> 2.0 sec
	Page length control	Control the page length of cut paper.	<b>by MENU setting</b> by Actual page length
	Cut sheet auto eject Position	Select a printable area at the bottom of cut sheets of paper in cut-paper mode (the character centre position).	<b>6.35 mm (3/12 ")</b> 12.70 mm(6/12 ") 14.82 mm (7/12 ")
	TOF adjust (Cut Sheet)	Select an adjustment value for the reference position in regard to the TOF position of cut-paper/passbooks.  The position moves to the rear of the form by [+] and to the top of the form by [-] in 1/180 in increments.	-30 - -1 <b>0</b> +30 - +1

MENU	ITEM	FUNCTION	SETTING
Top feed menu	Cut sheet top of form	Select the reference position for the TOF position when feeding cut-paper in manual mode. (Up to the mid-section of characters in the first line.)	2.12 mm (1/12 ") 4.23 mm (1/6 ") 6.35 mm (1/4 ") 8.47 mm (1/3 ") 10.58 mm (5/12 ") 12.70 mm (1/2 ") 14.82 mm (7/12 ") 16.93 mm (2/3 ") 19.05 mm (3/4 ") 21.17 mm (5/6 ") <b>23.28 mm (11/12 ")</b> 25.40 mm (1 ") 27.52 mm (13/12 ") Use top of form
	Cut sheet LF adjust	Adjust a line feed amount in cut-paper mode.	-14 - -1 <b>0</b> +14 - +1
Set-up menu	Graphics	Select the printing direction when bit image graphics print data exists in a line.	<b>Bi-directional</b> Uni-directional
	Receive buffer size	Select size of the received buffer.	1line 32 K <b>64 K</b>
	Paper out override	Select whether to detect paper end or not.	<b>No</b> Yes
	Print Registration 1	Adjust the print starting position on printing in the reverse direction. (The position moves to the right or left in 1/720 in increments.)	-10 - -1 <b>0</b> +10 - +1
	Print Registration 2	Adjust the print starting position on printing in the reverse direction. (The position moves to the right or left in 1/720 in increments.)	-10 - -1 <b>0</b> +10 - +1
	Print Registration 3	Adjust the print starting position on printing in the reverse direction. (The position moves to the right or left in 1/720 in increments.)	-10 - -1 <b>0</b> +10 - +1
	Print Registration 4	Adjust the print starting position on printing in the reverse direction. (The position moves to the right or left in 1/720 in increments.)	-10 - -1 <b>0</b> +10 - +1

MENU	ITEM	FUNCTION	SETTING
Set-up menu	Operator panel function	Select full or limited operation.	<b>Full operation</b> Limited operation
	Reset inhibit	Set whether to enable or disable an initial command.	<b>No</b> Yes
	Print suppress effective	Set whether to enable or disable a print suppress setup command.	<b>Yes</b> No
	Auto LF	Select whether to perform auto LF operation or not upon receiving a CR code.	Yes <b>No</b>
	Auto CR	Select whether to perform auto CR operation upon receiving a carriage return command. IBM PPR and IBM AGM emulation only	Yes <b>No</b>
	SI select pitch (10 CPI)	Set how to handle an SI command received in 10 CPI mode. IBM PPR and IBM AGM emulation only	15 CPI <b>17.1 CPI</b>
	SI select Pitch (12 CPI)	Set how to handle an SI command received in 12 CPI mode. IBM PPR and IBM AGM emulation only	<b>12 CPI</b> 20 CPI
	Time out print	Select valid or invalid.	<b>Valid</b> Invalid
	Auto Select	Select whether to automatically set Select Mode after paper feeding or not.	<b>Yes</b> No
	Host Interface	Select interface settings.	<b>Auto Interface</b> Parallel USB Serial
	I/F Time Out	Select timeout time for auto interfacing.	<b>15 sec</b> 30 sec 45 sec 1 min 2 min 3 min 4 min 5 min

MENU	ITEM	FUNCTION	SETTING
Set-up menu	Print Style	Set quiet printing.	<b>Normal</b> Quiet
	Centering position (continuous)	Set the centering position for the print head by the number of characters of 10CPI ANK.	<b>Default</b> Mode1 Mode2
	Centering position (cut sheet)	Set the centering position for the print head by the number of characters of 10CPI ANK.	<b>Default</b> Mode1 Mode2
	Power Save Time	Select the time to enter the Power Save mode.	<b>5 min</b> 10 min 15 min 30 min 60 min
	Paper End	Select whether a printer status where no paper is loaded is set to SEL or DESEL.	<b>On-line</b> Off-line
Parallel I/F	I-Prime	Set I-Prime signal control of the Centronics interface.	Invalid <b>Buffer Print</b> Buffer Clear
	Auto Feed XT	Set whether to enable or disable Auto Feed XT signal of the Centronics interface. (EPSON emulation only)	Valid <b>Invalid</b>
	Bi-Direction	Set whether to enable or disable Two-way communication of the Centronics interface.	<b>Enable</b> Disable
Serial I/F	Parity	Set parity.	<b>None</b> Odd Even Ignore
	Serial Data 7/8 Bits	Set serial data length.	<b>8 bit</b> 7 bit
	Protocol	Set protocols.	<b>DTR</b> X-ON/X-OFF DTR & X-ON/X-OFF
	Diagnostic Test	Set/Cancel loop testing of the serial interface.	<b>No</b> Yes

MENU	ITEM	FUNCTION	SETTING
Serial I/F	Baud Rate	Set the transmission speed of the serial interface.	<b>9,600 bps</b> 4,800 bps 2,400 bps 1,200 bps 600 bps 300 bps 19,200 bps
	DTR Signal	Set whether to switch the DTR signal of the serial interface by Select/Deselect or hold it after power-on.	<b>Ready on Power UP</b> Ready on Select
	Busy Time	Set the minimum time it takes to switch from a busy state to a ready state.	<b>0.2 sec</b> 1.0 sec

### INITIALISING MENU SETTINGS

To restore the menu settings to their initial values, carry out the steps below.

---

#### NOTE

*The values adjusted by the Adjustment menus are not initialised by the following procedure.*

---

1. Set the Power Switch to OFF.
2. Press and hold down the SEL and LF/FF buttons together and then set the Power Switch to ON.

### ADJUSTING TOF POSITION

Use the following procedure to set TOF to accord with the reference position (23.28 mm (11/12 in)). The reference position refers to the first line of the paper i.e. the position to which the printer feeds the paper when automatically loading the paper.

---

#### NOTE

*Adjusting of TOF can be done in cut sheet mode or continuous forms mode.*

---



1. Print out the menu settings of the printer as in "[Confirming current settings](#)" on page 47 and confirm that the TOF (in cut sheet mode or continuous forms mode) is 23.28 mm (11/12 in).
2. Set the Paper Type lever to the required paper type.
3. When continuous forms are used, place the paper on the Pin Tractor.  
For cut sheet mode, do not insert the paper at this stage.
4. In continuous forms mode, press the LOAD/EJECT button.  
In cut sheet mode, place the paper in the Paper Tray and press LOAD/EJECT.
5. Press the following buttons to adjust the first printing line:  
To feed the paper forward by a small amount, press and hold down the LOAD/EJECT button and then press the SEL button.  
To feed the paper backward by a small amount, press and hold down the LOAD/EJECT button and then press the LF/FF button.

---

*NOTE*

*If the specified correction range is more than +- 3.53 mm (20/144 in) for ML1120 and +- 4.23 mm (30/180 in) for ML1190, the paper cannot be moved.*

---

When the paper is positioned at the required TOF, release the buttons in Step 5 above.

---

*NOTE*

*Do not turn the Platen Knob or switch off the printer during the above procedure.*

---

## PRINTER SPEED SETTINGS

### PRINTER IMPACT MODE

When switched ON, the printer enters the impact mode selected in the menu. You can change this to normal speed, high speed and quiet printing without using the menus as follows.

(This function is enable for ML1120.)

### NORMAL SPEED PRINTING

Use this for standard file printing operations.

1. Ensure the SEL indicator is illuminated.
2. Hold down the SEL button and press the TEAR button.  
Status Indicator 1 turns off and Status Indicator 2 is illuminated.

### HIGH SPEED PRINTING

Use this for high speed printing.

1. Ensure the SEL indicator is illuminated.
2. Hold down the SEL button and press the TEAR button.  
Status Indicator 1 is illuminated and Status Indicator 2 turns off.

(High speed printing is applied only to the print of NLQ.)

### QUIET PRINTING

Use this for quieter printing.

1. Ensure the SEL indicator is illuminated.
2. Hold down the SEL button and press the TEAR button.  
Status Indicator 1 and Status Indicator 2 are illuminated.

## SETTING TOF POSITION AT THE PLACE OF USER'S CHOICE

TOF position can be set at the place of user's choice. The reference position refers to the first line of the paper i.e. the position to which the printer feeds the paper when automatically loading the paper.

---

### NOTE

*Adjusting of TOF can be done in cut sheet mode or continuous forms mode.*

---

1. Move Paper Lever to the position of the paper to be set.
2. Continuous paper: Set the paper in Pin Tractor.  
Single sheets: Do not insert the paper.
3. Continuous paper: Push the LOAD/EJECT button and the paper will be fed to the printer  
Single sheets: Set the paper in the tray and the paper will be fed to the printer.
4. Switch to the off line.
5. Push the LOAD/EJECT button continuously and adjust the position of printing start by combining the following buttons.  
Forward (minute reline): LOAD/EJECT button + SEL button  
Rear (minute reline): LOAD/EJECT button + LF/FF button

---

### NOTE

*The range set for TOF is between 2.12mm(1/12 in) and 368/4mm(14.5 in). Outside the range, the paper can not be moved.*

---

When the paper is positioned at the required TOF, release the buttons in Step 5 above.

To save this position as the TOF, press and hold down the LOAD/EJECT and the LF/FF buttons together for 3 seconds under the Select condition.

---

### NOTE

*Do not turn the Platen Knob or switch off the printer during the above procedure.*

---

# TROUBLESHOOTING

## CLEARING PAPER JAMS

### CUT SHEET PAPER JAMMED IN PRINTER

#### **WARNING!**

**Do not carry out any operations inside the printer with the Power Switch set to ON.**

1. Set the Power Switch to OFF.
2. Remove the Top Cover.

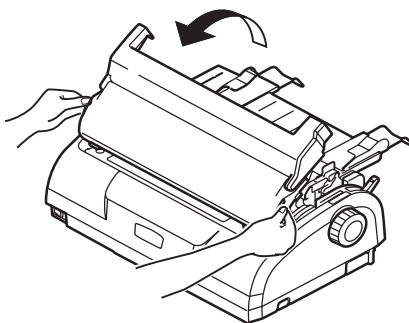

3. Set the Paper Thickness lever to the Replace Ribbon position (position 6).

#### **WARNING!**

**The Print Head may be hot after printing. Allow it to cool before touching it.**

4. Remove the ribbon cartridge. See "Changing a ribbon cartridge" on page 79.

5. Move the Print Head away from the paper.

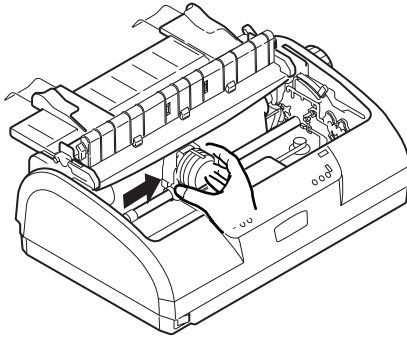

6. Rotate the Platen Knob in the relevant direction and pull the cut sheet out from the top of the printer.
7. If a paper fragment remains inside the printer:
  - (a) use tweezers to grip and extract it or
  - (b) insert a triple folded sheet from the Paper Tray and turn the Platen Knob to pass the folded sheet through and push out the paper fragment.



8. When the paper jams are cleared, replace the ribbon cartridge and replace the printer Top Cover.

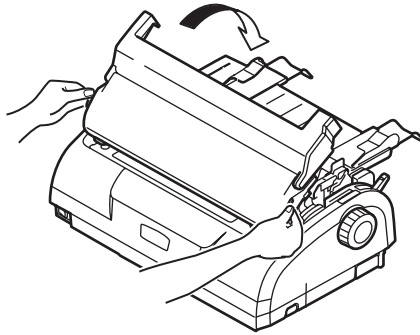

9. Set the Power Switch to ON.

#### CONTINUOUS FORMS JAMMED IN PRINTER

### WARNING!

**Do not carry out any operations inside the printer with the Power Switch set to ON.**

1. Set the Power Switch to OFF.
2. Tear off any unprinted continuous forms.
3. Remove the Paper Tray and Input Tray together, by gripping the Input Tray at both sides and pulling it up and away from the printer.

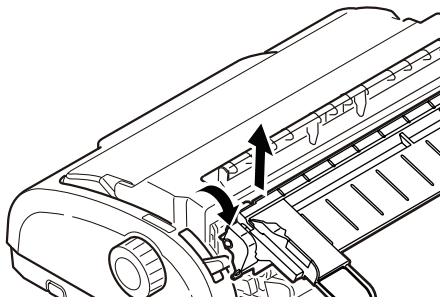

4. Raise each Pin Tractor cover and remove the continuous forms from the Pin Tractors.

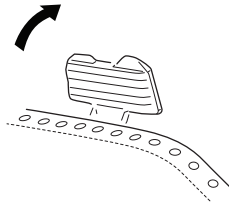

5. Rotate the Platen Knob and remove the forms from the front of the printer.
6. If a form fragment remains inside the printer, place two or three forms in a stack on the Pin Tractors and turn the Platen Knob to push the fragment out of the printer.
7. When the paper jams are cleared, replace the Input Tray and Paper Tray by fitting the Input Tray into the gooves at the back of the printer and pushing gently forward until the tray clips into place.

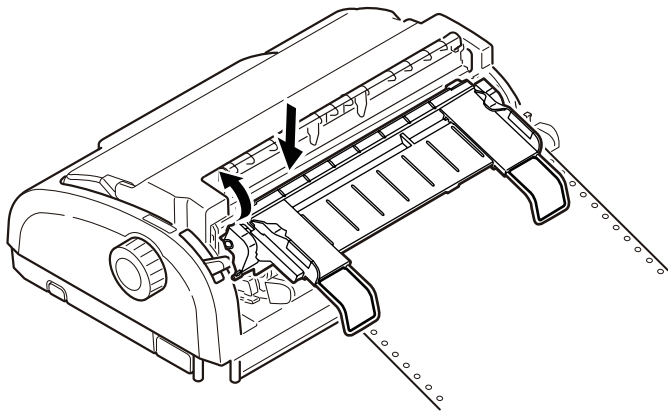

8. Set the Power Switch to ON.

## RESPONDING TO ALARM CONDITIONS

Use the following table for guidance on how to respond to indicated alarm conditions.

INDICATOR		ALARM MEANINGS AND ACTIONS
SEL	ALARM	
OFF	ON	Paper has run out. Add paper and press the SEL button.
OFF	Flashing	The Paper Type lever is wrongly set for the type of paper in use. Press the SEL button and set the Paper Type lever to the correct position.
OFF	Flashing	Problem with cut sheet feeding. Remove the cut sheet.
OFF	Flashing	Print data is received but printing does not start because no paper is being fed. Insert paper.
Flashing	Flashing	Printing cannot be resumed at this stage. Turn the power OFF, verify that the carriage moves properly, then turn the power ON again. If the problem is still there after you turn the power ON again, contact your dealer.

## RESPONDING TO GENERAL PROBLEMS

Use the following table to help you to identify symptoms with possible causes and take suggested remedial actions.

PROBLEM	CAUSE	ACTION
<b>No power</b>		
No power	The power cable is not properly connected.	Check the power cable is properly connected at both power outlet and printer.
	Power outlet problem or power outage.	Plug another appliance into this outlet to check if it works.
<b>No printing takes place</b>		
SEL indicator is unlit.	The printer driver is not installed properly.	Re-install the printer driver correctly.
	The printer has just stopped printing.	Press the SEL button.
	There is no paper in the printer.	Load paper.



<b>PROBLEM</b>	<b>CAUSE</b>	<b>ACTION</b>
SEL indicator is illuminated but no printing takes place.	Interface cable is disconnected.	Reconnect the interface cable.
	Wrong interface cable has been used.	Use correct interface cable.
The print head is moving but no printing takes place.	The ribbon cartridge has not been installed.	Install the ribbon cartridge.
<b>Print position offset</b>		
The horizontal printing position is offset.	The start position may change after the printer is powered on.	When the printer is powered ON, switch from off-line mode to on-line mode by pressing the SEL button. Reset the start position. You must set the Power Switch to OFF before you change the start position.
<b>Printing slows down</b>		
Print direction changes suddenly to unidirectional.	When the print head overheats, the printer automatically starts unidirectional split printing.	When the print head temperature drops sufficiently, the printer will return to its original operation.
<b>PE warning</b>		
The print carriage does not operate.	There is contamination on the carriage shaft.	Clean any paper dust and contamination from the carriage with a dry cloth.
<b>Print blurring</b>		
The characters are too pale to display properly on the paper.	The Paper Thickness lever position does not match the paper.	Correct the Paper Thickness lever setting.
	The printer is set to print at high speed.	Set the speed to normal.
	The ribbon has reached its end of life.	Replace the ribbon by a new one.
	The ribbon cartridge is not installed correctly.	Reinstall the ribbon cartridge correctly.
	The ribbon has been wound incorrectly.	Replace the ribbon cartridge by a new one.
	The ribbon is not transferring properly.	Replace the ribbon cartridge by a new one.
A line of print is missing.	Broken wire pins.	Contact your dealer.

PROBLEM	CAUSE	ACTION
<b>The printout differs from the screen display.</b>		
Printout of completely different characters or symbols.	Incorrect print setup for the user application.	Reselect print setup for the applications according to priority.
	The application control codes for the previous print operation are still enabled.	Initialise the printer.
	The input application control signal is not correct.	Print in hex dump mode and verify the data content. Make corrections in the application.
	The interface cable is not properly connected.	Reconnect the cable correctly.
Too high or too low TOF (where printing starts).	The TOF is not correctly selected.	Initialise the printer.
		Select correct TOF for cut sheet and continuous forms.
		Select the first-line print position and adjust the paper top position.
		Reselect the margin correctly in the application.
Too large or small left and/or right margins.	The left or right margin is not correctly selected.	Incorrect positions of the Paper Guide or Pin Tractors. Select and adjust the position again depending on the paper type.
		Reselect the left and right margins correctly in the application.
When continuous forms are used, the content of a single form is printed on two forms.	The paper length selected in the application does not match the physical paper length.	Match the paper length selected in the application with the physical paper length in use.
When cut sheets are used, the content of a single sheet is printed on two sheets.	The paper setting selected in the application does not match the physical paper size.	Match the paper setting selected in the application with the physical paper in use.
	It does not match the lines per page as the printer automatically detected.	Leave enough top and bottom margin in the application. Correct the cut sheet LF adjustment.
The content of a single line is printed in two lines.	The left and/or right margins are not correctly selected.	Reselect the left and right margins correctly in the application.
When continuous forms are used, several blank lines appear in the printout.	Tear-off perforation spacing is selected.	Cancel tear-off perforation spacing.

<b>PROBLEM</b>	<b>CAUSE</b>	<b>ACTION</b>
Broken and uneven vertical lines.	This may happen in bidirectional printing.	Use Print Registration in the adjustment mode to adjust.
Too large or small line spacing.	Line spacing is not selected correctly.	Reselect line spacing correctly in the application.
<b>Split print</b>		
Blanks appear in graphic printout.	This is a paper feed error, which is especially notable in printing regular characters.	This is not a failure.
Blanks or deformed characters appear in double height type or other extended types.	This is a paper feed error due to line feeding in printing a single character.	This is not a failure. Use the printer's built-in fonts when you print important documents or bills.
<b>Improper cut sheet feed</b>		
No paper feed.	Sheets are located off the paper guide.	Load sheets with their left edges against the paper guide.
	Sheets are not loaded to the end.	Load sheets to the end.
The platen rotates without paper feed, or continuous forms instead of cut sheets are fed.	Sheets are not loaded to the end.	Load sheets to the end.
	The printer is in the continuous forms mode.	Eject the continuous forms and select cut sheet mode for the printer.
Paper distortion.	Sheets are not loaded to the end, or they are not inserted straight.	Load sheets to the end.
	Paper with wrinkles, folds or other defects.	Change paper.
	Paper not specified for the printer.	Use paper types specified for the printer.
Unable to eject.	The LF/FF button is pressed.	Press the LOAD/EJECT button.
<b>Improper continuous forms feed.</b>		
No line feed, and no paper feed.	Paper is off the Pin Tractors.	Reload paper correctly.
	The adjust lever position does not match the paper type.	Set the adjust lever to the correct position.

PROBLEM	CAUSE	ACTION
Paper distortion or jam.	Forms are loaded with their left holes out of line with the right ones.	Load forms with their left holes in line with the right ones.
	Inadequate distance between the left and right Pin Tractors, making for loose paper.	Relocate the Pin Tractors to tighten the paper.
	Paper movement is blocked.	Remove the blockage.
	Paper source is too far from the printer.	Move the paper source nearer to the printer.
	Paper not specified for the printer.	Use paper types specified for this printer.
Several blank lines appear in the printout.	Skip over perforation spacing is selected.	Cancel the skip over perforation spacing.
The selected skip over perforation spacing does not match the physical tear-off perforation positions.	The paper length selected in the application does not match the physical paper length.	Match the paper length selected in the application with the physical paper length in use.  Select the paper length in number of lines in the application.
<b>Abnormal switchover between cut sheet and continuous forms modes.</b>		
No cut sheet feed.	The printer is in continuous forms mode.	Set the Paper Type lever to cut sheet mode.
No continuous forms feed.	The printer is in cut sheet mode.	Set the Paper Type lever to continuous forms mode.
Paper feed operations for both cut sheets and continuous forms are actuated.	The cut sheet is not ejected.	Eject the cut sheet.

## CLEANING YOUR PRINTER

To keep your printer in good operating condition, you are advised to clean it regularly.

### WARNING!

**Set the printer Power Switch to OFF and disconnect the power cable from the printer before cleaning the printer.**

## PRINTER EXTERIOR

### CAUTION!

**Keep the Top Cover closed to avoid the possibility of detergent entering the printer**

Clean the exterior of the printer as required, but at least every six months or 300 hours of operation, whichever comes first.

1. Moisten a piece of cotton cloth with diluted neutral detergent and carefully wipe the printer exterior.

## PRINTER INTERIOR

### WARNING!

**As the print head becomes hot during printing, allow it to cool before carrying out any cleaning inside the printer.**

**Do not use any flammable solvents for cleaning the printer to avoid any risk of fire or electric shock.**

Clean the interior of the printer every 6 months or 300 hours of operation, whichever comes first.

Using a soft cloth, cotton swabs and a vacuum cleaner, clean the interior of the printer as follows:

WHERE TO CLEAN	WHAT TO CLEAN
The carriage and the area around it	Clean and remove paper waste, dirt, dust and ribbon shreds.
The paper travel surface	

**CAUTION!**

**When you clean the interior of the printer with a vacuum cleaner, do not attempt to clean any parts smaller than the suction nozzle.**

**Do not clean any interior working parts with the suction nozzle to avoid possible damage to the printer.**

# CONSUMABLES AND ACCESSORIES

## CONSUMABLES

When the printed image becomes faint or incomplete, replace the ribbon cartridge.

### CHANGING A RIBBON CARTRIDGE

#### CAUTION!

**Only use genuine Oki Original consumables to ensure the best quality and performance from your hardware. Non-Oki Original products may damage your printer's performance and invalidate your warranty.**

#### WARNING!

**Do not change the ribbon cartridge with the Power Switch set to ON.**

1. Set the Power Switch to OFF.
2. Set the Paper Thickness lever to Replace Ribbon (position 6).
3. Remove the Top Cover.

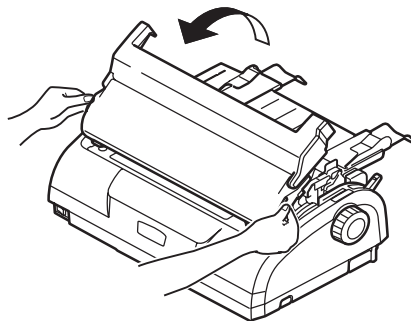

## WARNING!

The print head and area around it may be hot after printing.  
Allow it to cool down before touching it.

4. Grip the ribbon cartridge with your fingers at each end and slope it up and out to remove it from the carriage.

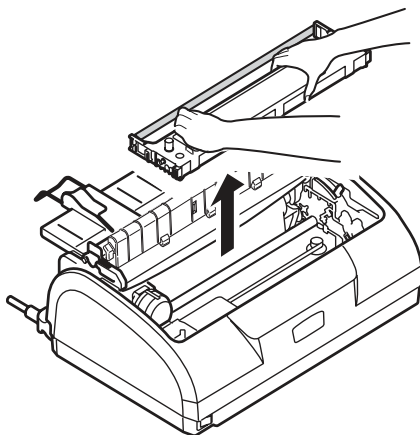

5. Dispose of the cartridge in accordance with your local guidelines.
6. Remove the new ribbon cartridge from its wrapping and note the position of the Ribbon Guide (1), blue Knob (2) and Pin (3).

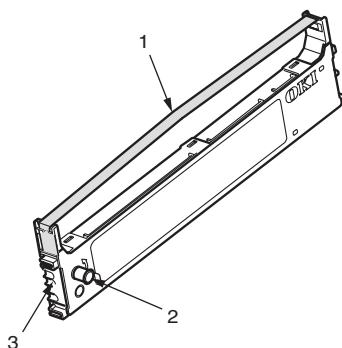



7. In the direction indicated by the arrows, insert the pins at both ends of the ribbon cartridge into the U grooves in the printer until the ribbon cartridge is fully locked.

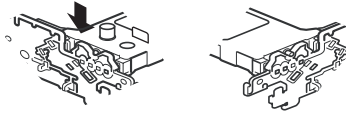

---

**NOTE**

*It may be easier to mount the ribbon cartridge in place if you align it with the topside of the grooves. Also, a slightly loose ribbon may make it easier to mount the ribbon cartridge.*

---

8. Hold the ribbon cartridge with your fingers pressing on its ribbon guide and slope it upward and inward along the guide rails until the ribbon guide comes in line with the U slot at the top of the cartridge.
9. Turn the blue knob anticlockwise (in the direction of the arrow) to wind up the ribbon.

**CAUTION!**

**Do not turn the knob clockwise as the ribbon might jam.  
Make sure that the ribbon is not twisted or damaged when it goes through the gap between the Print Head and the ribbon guide.**

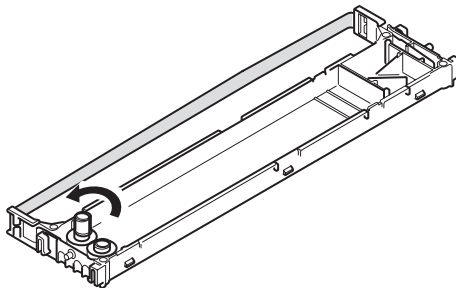

10. Replace the Top Cover.

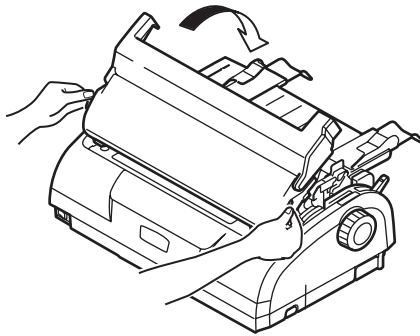

11. Set the Paper Thickness lever to match the paper being used.  
(See "Setting the Paper Thickness lever" on page 41.)
12. Set the printer Power Switch to ON.

#### CONSUMABLE ORDER INFORMATION

ITEM	LIFE	ORDER NO.
Ribbon cartridge (Black)	4 million characters	43571806

# SPECIFICATIONS

## ML1120

ITEM	SPECIFICATION
Product Name	ML1120
Model No.	D22400B
Print method	Impact dot matrix
Print head	9 pins, 0.3 mm (0.0118 in) diameter
Print direction	Bi-directional, short-line-seeking printing
Print speed High Speed Draft (HSD) Letter Quality (LQ) Utility	333 cps @ 10 cpi 62.5 cps @ 10 cpi 250 cps @ 10 cpi
Line Feed (LF) time	Approximately 52 ms per line for LF of 4.23 mm (1/6 in)
Form Feed (FF) speed	Approximately 101.6 mm/s (4.0 in/s)
Paper feed control	Paper feed: yes Vertical tab: yes Direct line feed: yes
Duplication capability	Continuous forms: the original page +4 more pages (total maximum paper thickness less than 0.325 mm) Cut sheet: the original page +4 more pages (total maximum paper thickness less than 0.325 mm)
Feeding direction	Feed forward Feed backward
Feeding mode	Friction feed mode (top) Pin tractor feed mode (rear)
Continuous forms tape tail detection method	Detected when remaining paper is approximately 46 mm long. It can, however, print till about 6 mm from the paper bottom (measured at the centre of the characters).  (The print accuracy of the last page cannot be guaranteed.)
Character sets	Standard ASCII Epson (Italics/Graphics) IBM (Set1/Set2) ML Foreign Code Page
Media	See "Setting the Paper Thickness lever" on page 41.

ITEM	SPECIFICATION
Original OKI cartridge ribbon Ink color Ribbon life	Black 4 million characters (Utility mode)
Print head life	200 million characters (Utility mode)
Dimensions	349 mm (W) x 150 mm (H) x 232 mm (D) with platen knob installed
Weight	Approximately 4.4 kg
Power rating Voltage Frequency	220 - 240V $\pm$ 10% 50/60 Hz $\pm$ 1 Hz
Power consumption Operation (ISO/IEC10561 letter pattern) Powersave mode	33 W or less 2.5 W or less
Power cable	3 - core AC power cable, approximately 1.8 m length
Interfaces	Bi-directional parallel, IEEE1284-1994 USB 2.0 RS-232C
Dust and corrosion	Use the printer in a general office environment.
Environmental conditions Operating Storage	5°C to 35°C, 20% to 80% RH (Testing condition for print precision: 15°C to 30°C, 40% to 70%RH) -10°C to 50°C, 5% to 95% RH When the printer is stored, it should be in its original packaging, with no moisture formation.
Standard usage Average power on time Average printing time	200 h/month 50 h/month (text density on page: 35%)
Noise level	The acoustic noise of this product is less than 55 dB (A) as measured in accordance with EN ISO 7779.

## ML1190

ITEM	SPECIFICATION
Product Name	ML1190
Model No.	D22410B
Print method	Impact dot matrix
Print head	24 pins, 0.2 mm (0.0079 in) diameter
Print direction	Bi-directional, short-line-seeking printing
Print speed High Speed Draft (HSD) Letter Quality (LQ) Utility	333 cps @ 10 cpi 83 cps @ 10 cpi 250 cps @ 10 cpi
Line Feed (LF) time	Approximately 47 ms per line for LF of 4.23 mm (1/6 in)
Form Feed (FF) speed	Approximately 109.2 mm/s (4.3 in/s)
Paper feed control	Paper feed: yes Vertical tab: yes Direct line feed: yes
Duplication capability	Continuous forms: the original page +4 more pages (total maximum paper thickness less than 0.325 mm) Cut sheet: the original page +4 more pages (total maximum paper thickness less than 0.325 mm)
Feeding direction	Feed forward Feed backward
Feeding mode	Friction feed mode (top) Pin tractor feed mode (rear)
Continuous forms tape tail detection method	Detected when remaining paper is approximately 46 mm long. It can, however, print till about 6 mm from the paper bottom (measured at the centre of the characters). (The print accuracy of the last page cannot be guaranteed.)
Character sets	Standard ASCII Epson (Italics/Graphics) IBM (Set1/Set2) ML Foreign Code Page
Media	See "Setting the Paper Thickness lever" on page 41.
Original OKI cartridge ribbon Ink color Ribbon life	Black 4 million characters (Utility mode)
Print head life	200 million characters (Utility mode)

ITEM	SPECIFICATION
Dimensions	349 mm (W) x 150 mm (H) x 232 mm (D) with platen knob installed
Weight	Approximately 4.4 kg
Power rating Voltage Frequency	220 - 240V $\pm$ 10% 50/60 Hz $\pm$ 1 Hz
Power consumption Operation (ISO/IEC 10561 letter pattern) Powersave mode	41 W or less 2.5 W or less
Power cable	3 - core AC power cable, approximately 1.8 m length
Interfaces	Bi-directional parallel, IEEE1284-1994 USB 2.0 RS-232C
Dust and corrosion	Use the printer in a general office environment.
Environmental conditions Operating Storage	5°C to 35°C, 20% to 80% RH (Testing condition for print precision: 15°C to 30°C, 40% to 70%RH) -10°C to 50°C, 5% to 95% RH When the printer is stored, it should be in its original packaging, with no moisture formation.
Standard usage Average power on time Average printing time	200 h/month 50 h/month (text density on page: 35%)
Noise level	The acoustic noise of this product is less than 53 dB (A) as measured in accordance with EN ISO 7779.

# INDEX

## A

alarm indications.....	62
aligning perforations.....	28

## B

buttons.....	37
--------------	----

## C

cleaning	
exterior.....	67
interior.....	67

## D

drivers.....	16
--------------	----

## E

ejecting paper	
continuous forms.....	28
cut sheet.....	23

## F

fault finding.....	62
--------------------	----

## I

indicators.....	34
interface	
parallel.....	15
serial.....	15
USB.....	15

## L

loading paper	
continuous forms.....	24
cut sheet.....	21

## M

menu settings	
changing.....	39
confirming.....	38
initialising.....	55
list.....	40

## N

normal speed printing.....	57
----------------------------	----

## P

paper jams	
continuous forms.....	60
cut sheet.....	58
printer	
control panel.....	33
location.....	12
parts.....	9
test print.....	13

printing files.....	17
---------------------	----

## Q

quiet printing.....	57
---------------------	----

## R

ribbon	
changing.....	69
ordering.....	72

## S

setting paper thickness.....	31
specifications.....	73
switching ON.....	12

## T

test page.....	16
TOF	
saving.....	55
setting.....	55

## U

user guide	
list.....	6
printing.....	7

## OKI CONTACT DETAILS

**Oki Data (Singapore) Pte. Ltd.**  
438 A Alexandra Road #02-11/12,  
Lobby 3, Alexandra Technopark  
Singapore (119967)

Tel:(65) 6221 3722  
Fax:(65) 6594 0609  
<http://www.okidata.com.sg>

**Oki Systems (Thailand) Ltd.**  
1168/79, 81-82 Lumpini Tower,  
27th Floor, Rama IV Road,  
Tungmahamek, Sathorn  
Bangkok 10120,  
Thailand

Tel:(+662) 679 9235  
Fax:(+662) 679 9245  
<http://www.okisysthai.com>

**OkiData (Australia) Pty. Ltd.**  
Level1 67 Epping Road, Macquarie Park  
NSW 2113, Australia

Tel: +61 2 8071 0000  
(Support Tel: 1800 807 472)  
Fax:+61 2 8071 0010  
<http://www.oki.com.au>

**Comworth Systems Ltd.**  
8 Antares Place Rosedale,  
Auckland 0632, New Zealand

Tel:(64) 9 477 0500  
Fax:(64) 9 477 0549  
<http://www.comworth.co.nz>

**OkiData(S) P Ltd. Malaysia Rep Office**  
Suite 21.03, 21st Floor Menara IGB,  
Mid Valley City,  
Lingkaran Syed Pura 59200,  
Kuala Lumpur, Malaysia

Tel:(60) 3 2287 1177  
Fax:(60) 3 2287 1166



