

FEATURES

- High Output Voltage: >7.5Vpp
- Output Crossing Point Control Function
- Output Amplitude Control Function
- Integrated Bias Inductor

FUNCTION DIAGRAM

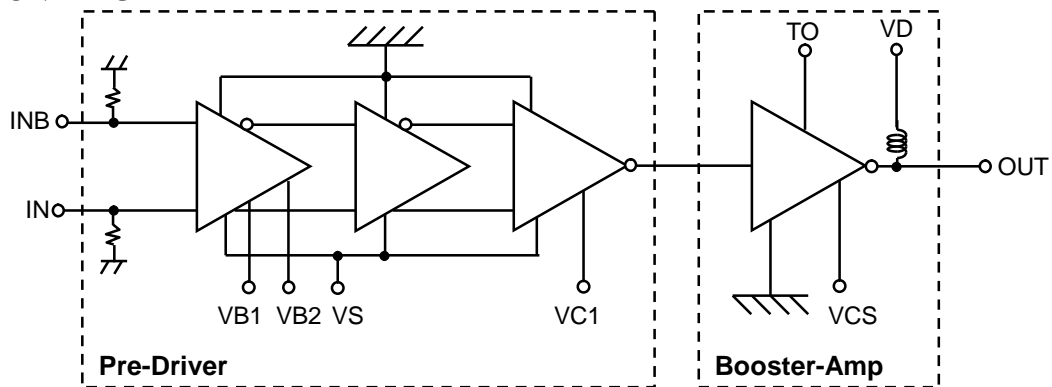

ABSOLUTE MAXIMUM RATINGS

Parameter	Symbol	Min	Max	Unit
Supply Voltage ^{*1}	VS	-6.5	0.3	V
Crossing Point Control Voltage	VB1	VS-4.5 (Min. -6.5)	VS+2.4 (Max. 0.3)	V
Crossing Point Reference Voltage	VB2	VS-4.5 (Min. -6.5)	VS+2.4 (Max. 0.3)	V
Internal Amplitude Control Voltage	VC1	-6.5	VS+1.2 (Max. 0.3)	V
Cascode FET Gate Voltage	VCS	-0.2	0.2 x VD	V
DC Bias for Output Stage Amplifier ^{*2}	VD	0	6.5	V
Allowable Current of Output Stage Amplifier	ID_MAX		380	mA
Allowable Maximum Output Amplitude	Vo_MAX		9.5	Vpp
Operating Temperature at Package Base	Ts	-10	100	°C
Storage Temperature	Tst	-40	125	°C

*1 Keep VS below 0V, during power of VD supplied.

*2 Assuming None-Return-Zero(NRZ) signal format.

RECOMMENDED OPERATING CONDITIONS

Parameter	Symbol	Min	Typ	Max	Unit
Supply Voltage	VS	-5.46		-4.94	V
Crossing Point Control Voltage	VB1	VS+0.8		VS+1.7	V
Crossing Point Reference Voltage	VB2	-4.2	-3.95	-3.7	V
Internal Amplitude Control Voltage	VC1	VS		VS+1.0	V
Cascode FET Gate Voltage	VCS	0		0.17 x VD	V
DC Bias for Output Stage Amplifier ^{*1,2}	VD	0.5		6.0	V
Operating Temperature at Package Base	Ts	-5		85	°C
Input Interface ^{*3}	AC coupled (External blocking capacitor is required)				
Output Interface ^{*4}	AC coupled (External blocking capacitor is required)				

*1 Output Amplitude can be tuned by control voltage VD.

*2 External inductor for low frequency is required.

*3 NRZ signal format with 50Ω source and load impedance.

ELECTRICAL CHARACTERISTICS

Parameter	Symbol	Condition	Min	Typ	Max	Unit
Maximum Input Data Rate			11.3			Gbps
Supply Current of VS	I _{SS}	VC1=VS+1V, VCS=0.7V, Crossing Point(Xp)=50%		110		mA
Supply Current of VD	I _D	VC1=VS+1V, VCS: Open, Xp=50%		320		mA
Power Consumption	P _{wr}	Vo=6V _{pp} , VC1=VS+1V, VCS: Open, Xp=50%		1.5		W
Input Amplitude	V _{in}	Differential (AC Coupled)	0.2		0.75	V _{pp}
		Single-Ended (AC Coupled)	0.4		1	V _{pp}
Output Amplitude (Max)	V _o (Max)	VD=6V, VC1=VS+1V, VCS=0.7V, Xp=50%	7.5			V _{pp}
Output Amplitude (Min)	V _o (Min)	Xp=50%		4.5		V _{pp}
Output Rise/Fall Time	Tr/Tf	20%-80%			40	ps
Input Return Loss	S11	100kHz-10 GHz		13		dB
Output Return Loss	S22	100kHz-10 GHz		13		dB

PACKAGE DIMENSIONS

(Top View)

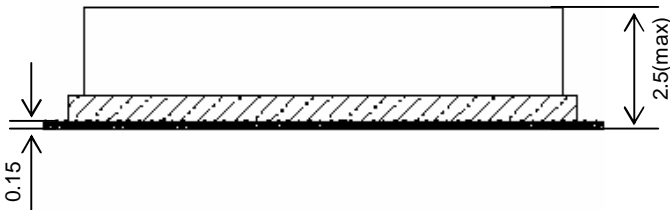
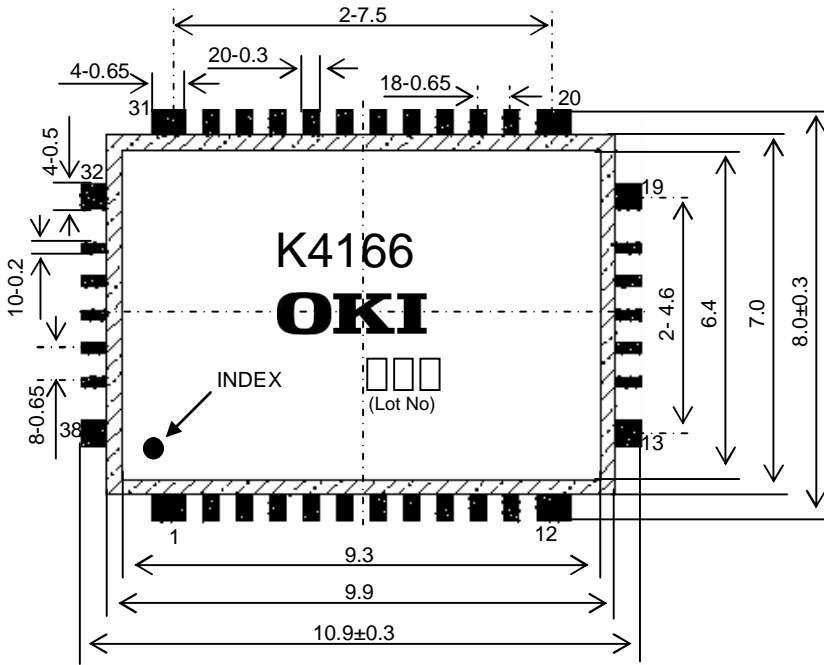

(Bottom View)

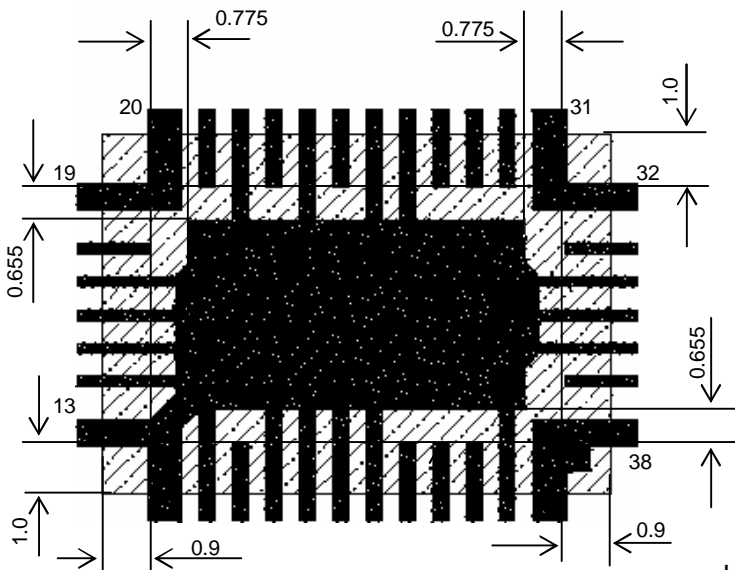

Unit: mm

This package is non-hermetic.

PIN ASSIGNMENT

No.	Symbol	Note
1	GND	Ground
2	GND	Ground
3	VC1	Internal Amplitude Control Port
4	GND	Ground
5	VCS	Cascode FET Gate Bias Port
6	GND	Ground
7	GND	Ground
8	GND	Ground
9	GND	Ground
10	VD	Output Stage Amplifier DC Bias Port
11	GND	Ground
12	GND	Ground
13	GND	Ground
14	GND	Ground
15	GND	Ground
16	GND	Ground
17	GND	Ground
18	Out	Signal Output Port
19	GND	Ground
20	GND	Ground
21	GND	Ground
22	GND	Ground
23	GND	Ground
24	GND	Ground
25	TO	Output Termination Port
26	GND	Ground
27	GND	Ground
28	VS	Supply Voltage Port
29	VB2	Crossing Point Reference Port
30	VB1	Crossing Point Control Port
31	GND	Ground
32	GND	Ground
33	INB	Inverted Input Port
34	GND	Ground
35	GND	Ground
36	GND	Ground
37	IN	Signal Input Port
38	GND	Ground

TYPICAL APPLICATION

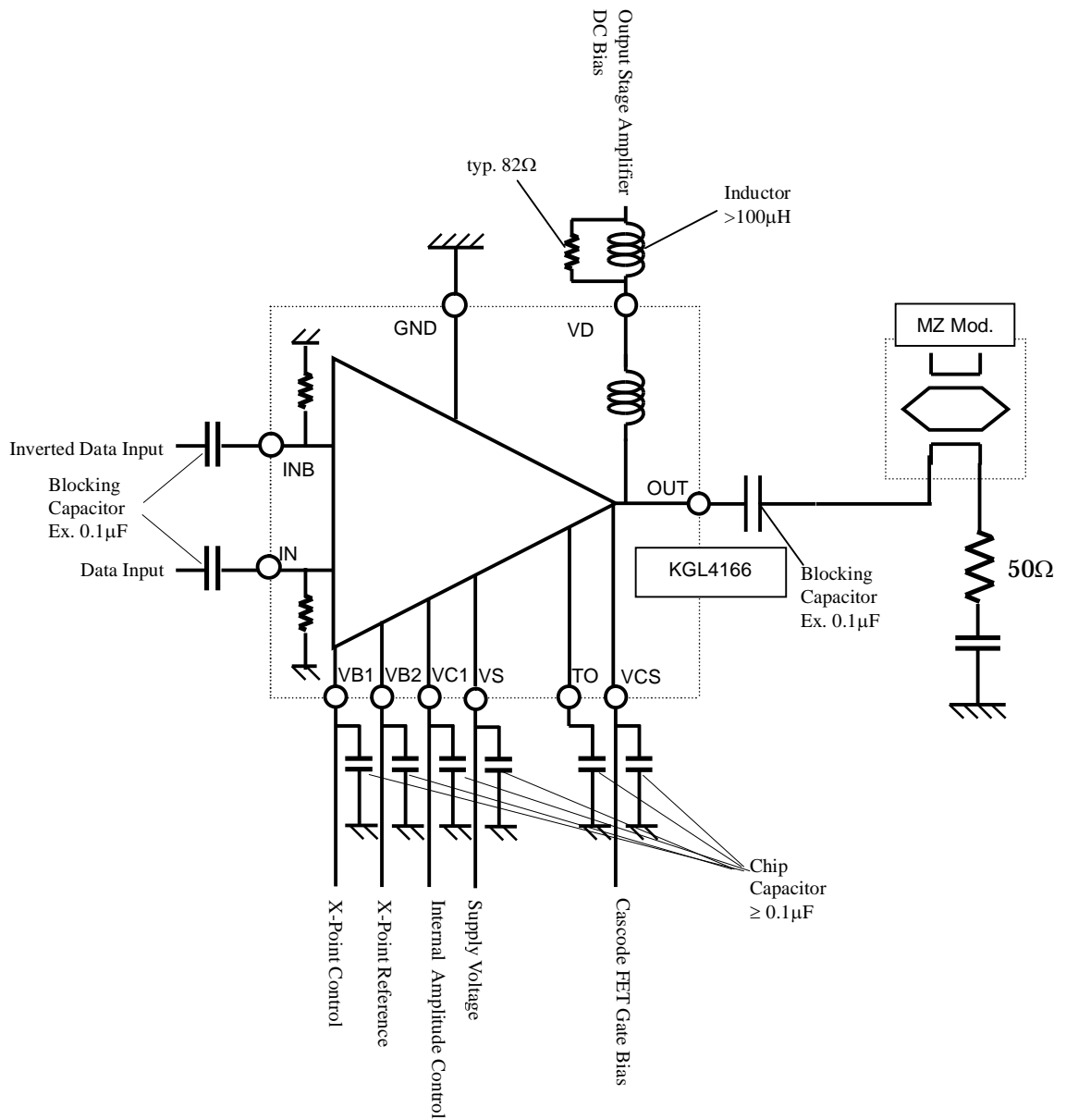

TO port: Do not connect any voltage sources or grounds.

APPLICATION NOTE

1. For stable operation;
 - a) To prevent a dependence of the output crossing point on the supply voltage VS,
 - Case 1 : VB2 is open
 - VB2 is biased at about $0.76 \times VS$ ($-3.95V@VS=-5.2V$) by the internal circuit.
 - Control VB1, so that the voltage difference "VB1-VB2" is constant.
 - Case 2 : VB2 is biased
 - Bias VB2 at about $-3.95V$ by using the external voltage source independent of VS.
 - Control VB1 by using the external voltage source independent of VS.
 - b) To prevent a dependence of "Output amplitude" on the supply voltage VS
 - Control the voltage of "VC1", so that the voltage difference "VC1-VS" is constant.
2. Power-up/shut-down sequence;
 - Power-up sequence:
 - Set input signals (IN/INB) on
 - Set VB1, VB2 (if required) and VC1 on (Don't care about the order)
 - Set VS on
 - Set VD on
 - Set VCS on
 - Shut-down sequence:
 - Set VCS off
 - Set VD off
 - Set VS off
 - Set VB1, VB2 (if required), VC1 off (Don't care about the order)
 - Set input signals (IN, INB) off

SAFETY AND HANDLING INFORMATION ON GaAs DEVICES

Arsenic Compound (GaAs Devices)

The product contains arsenic (As) as a compound.

This material is stable for normal use, however, its dust or vapor may be potentially hazardous to the human body.

Avoid ingestion, fracture, burning or chemical treatment to the product.

- Do not put the product in your mouth.
- Do not burn or destroy the product.
- Do not perform chemical treatment for the product.

Keep laws and ordinances related to the disposal of the products.

ESD CONSIDERATIONS

This device can be damaged by ESD; therefore appropriate precautions must be taken to avoid exposure to ESD and EOS during handling, assembly, and testing of these devices. Failure to adhere to proper ESD/EOS precautions during handling and assembly of these devices can damage or adversely affect device reliability.

NOTICE

1. The information contained herein can change without notice owing to product and/or technical improvements. Before using the product, please make sure that the information being referred to is up-to-date.
2. The outline of action and examples for application circuits described herein have been chosen as an explanation for the standard action and performance of the product. When planning to use the product, please ensure that the external conditions are reflected in the actual circuit, assembly, and program designs.
3. When designing your product, please use our product below the specified maximum ratings and within the specified operating ranges including, but not limited to, operating voltage, power dissipation, and operating temperature.
4. Oki assumes no responsibility or liability whatsoever for any failure or unusual or unexpected operation resulting from misuse, neglect, improper installation, repair, alteration or accident, improper handling, or unusual physical or electrical stress including, but not limited to, exposure to parameters beyond the specified maximum ratings or operation outside the specified operating range.
5. Neither indemnity against nor license of a third party's industrial and intellectual property right, etc. is granted by us in connection with the use of the product and/or the information and drawings contained herein. No responsibility is assumed by us for any infringement of a third party's right which may result from the use thereof.
6. The products listed in this document are intended for use in general electronics equipment for commercial applications (e.g., office automation, communication equipment, measurement equipment, consumer electronics, etc.). These products are not authorized for use in any system or application that requires special or enhanced quality and reliability characteristics nor in any system or application where the failure of such system or application may result in the loss or damage of property, or death or injury to humans. Such applications include, but are not limited to, traffic and automotive equipment, safety devices, aerospace equipment, nuclear power control, medical equipment, and life-support systems.
7. Certain products in this document may need government approval before they can be exported to particular countries. The purchaser assumes the responsibility of determining the legality of export of these products and will take appropriate and necessary steps at their own expense for these.
8. No part of the contents contained herein may be reprinted or reproduced without our prior permission.

Copyright 2007 Oki Electric Industry Co., Ltd.